

D	Originalbetriebsanleitung Dekupiersäge	SLO	Originalna navodila za uporabo Dekupirna žaga
GB	Original operating instructions Scroll Saw	H	Eredeti használati utasítás Levágó fűrész
F	Instructions d'origine Scie de découpage	RO	Instrucțiuni de utilizare originale Ferăstrău pentru decupat
I	Istruzioni per l'uso originali Sega a svolgere	GR	Πρωτότυπες Οδηγίες χρήσης Πριόνι εναλλασσόμενης ενέργειας
DK/ N	Original betjeningsvejledning Dekupørsav	P	Manual de instrucções original Serra Pendular
S	Original-bruksanvisning Kontursåg	HR/ BIH	Originalne upute za uporabu Pila za izrezivanje
CZ	Originální návod k obsluze Vykrúžovací píla	RS	Originalna uputstva za upotrebu Testera za izrezivanje
SK	Originálny návod na obsluhu Lupienková píla	PL	Instrukcją oryginalną Wyrzynarka stołowa
NL	Originele handleiding Decoupeerzaag	TR	Orijinal Kullanma Talimatı Tezgah Dekupaj Testeresi
E	Manual de instrucciones original Sierra de marquetería	EE	Originaalkasutusjuhend Vineerisaag
FIN	Alkuperäiskäyttöohje Kuviosaha		

13



Art.-Nr.: 43.090.47

I.-Nr.: 21012

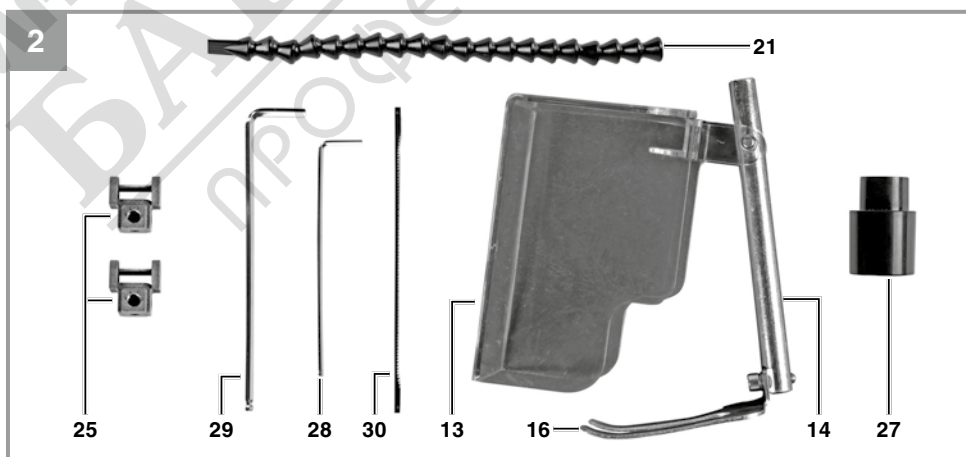
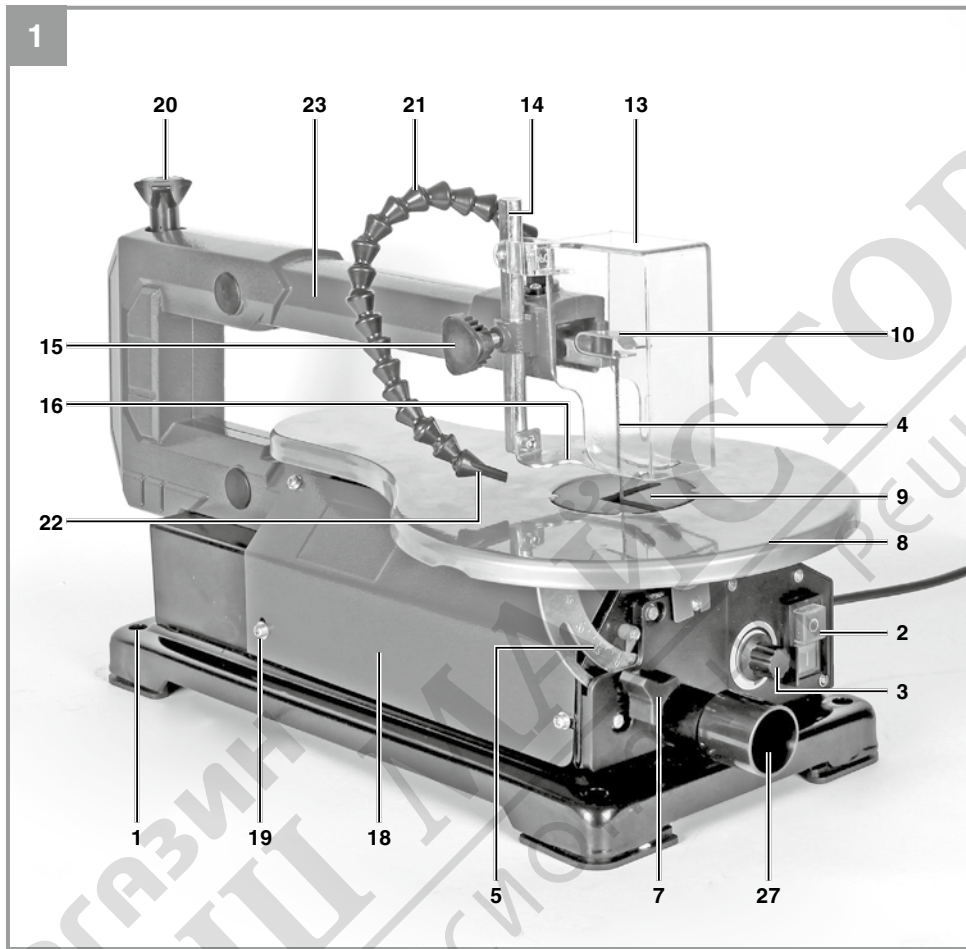

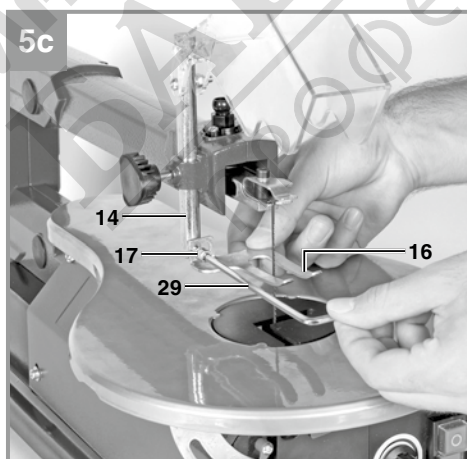
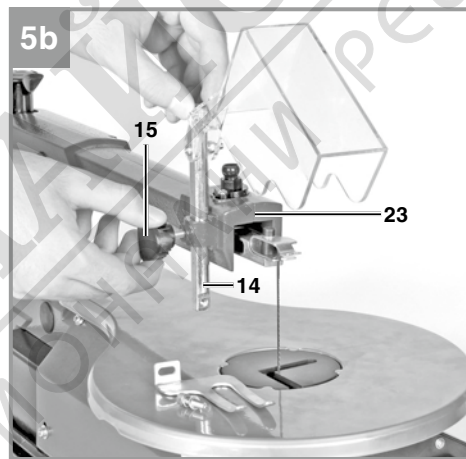
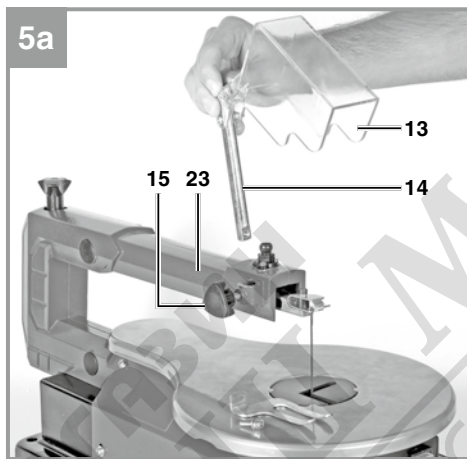
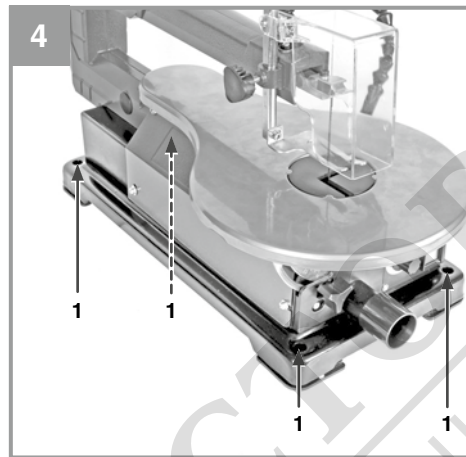
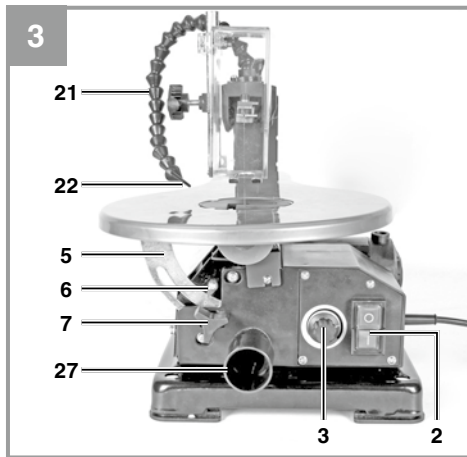

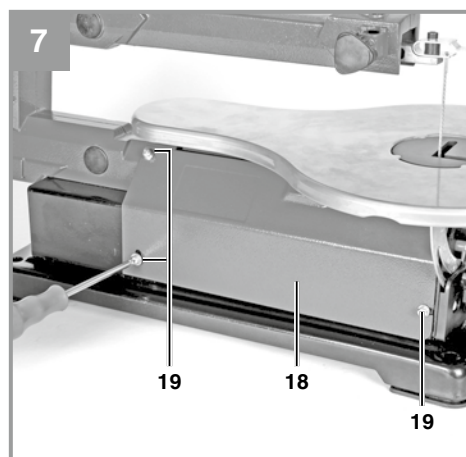
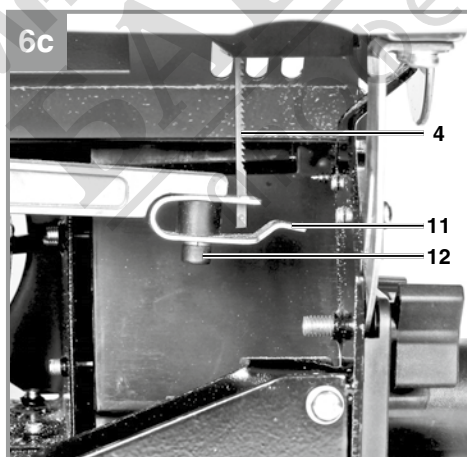
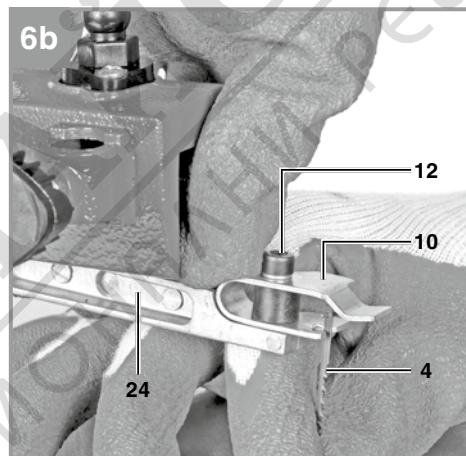
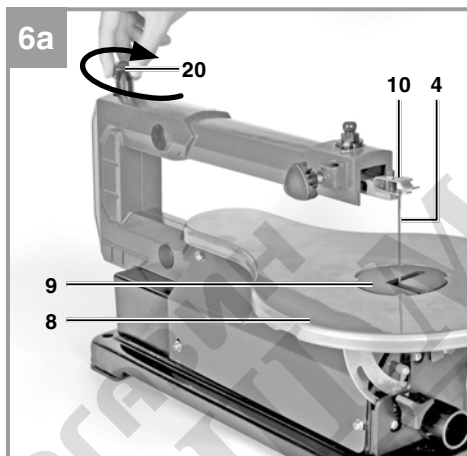
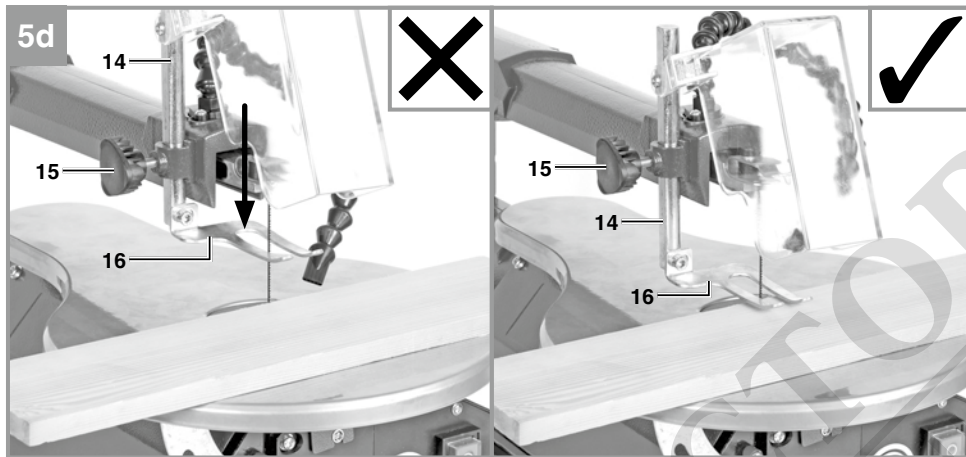

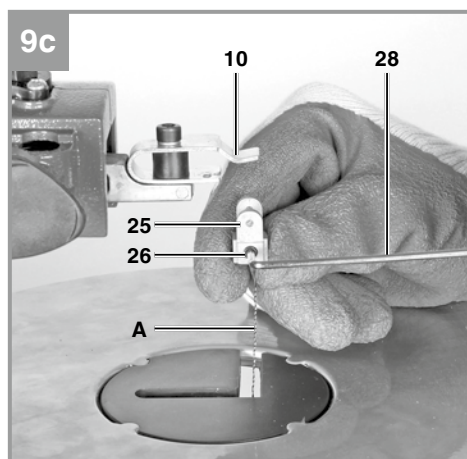
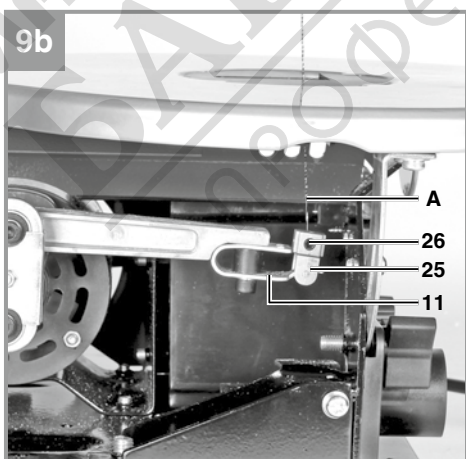
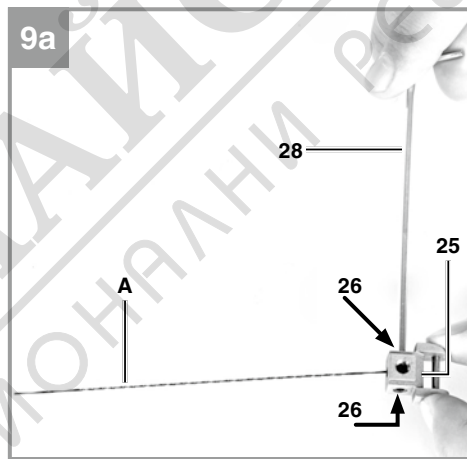
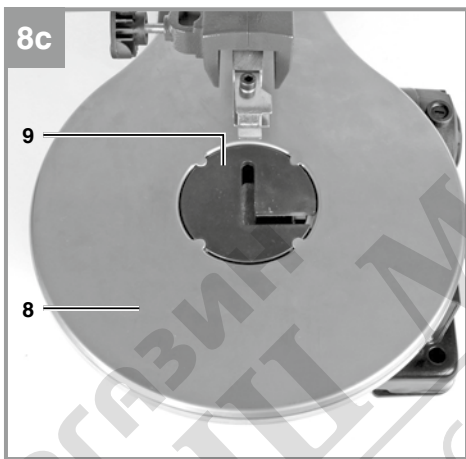
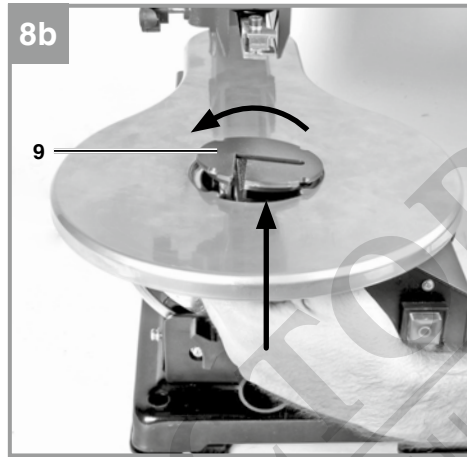
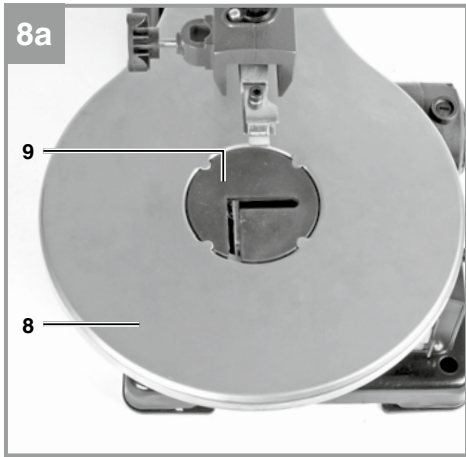

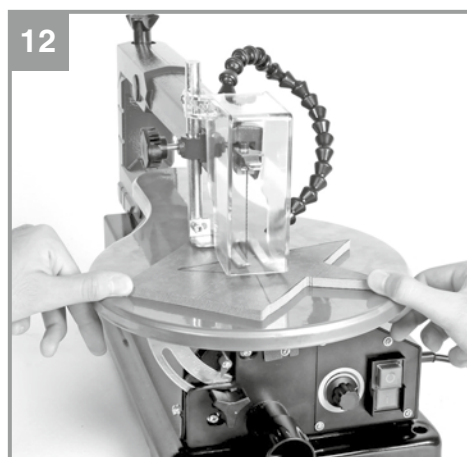
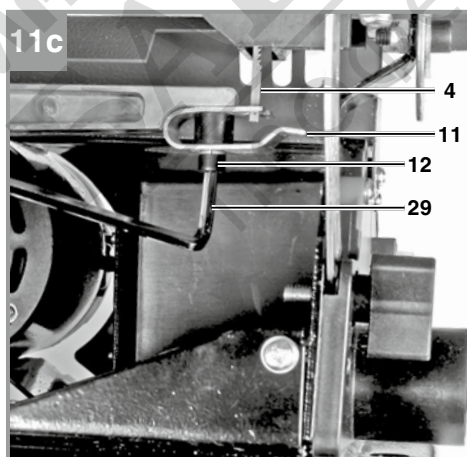
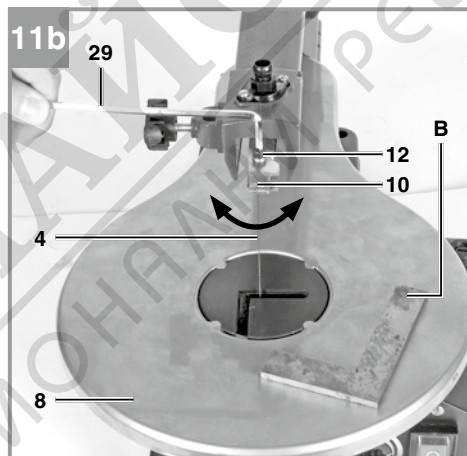
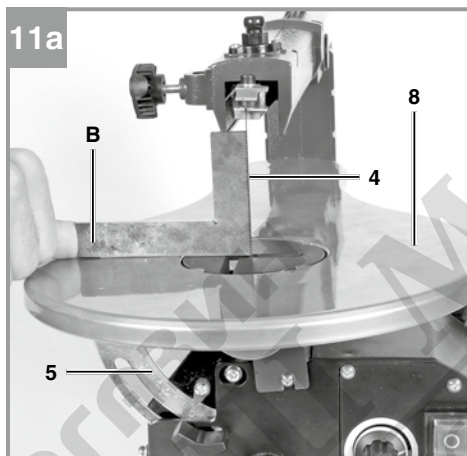
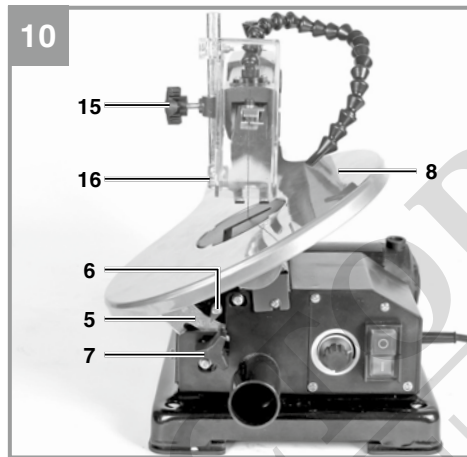
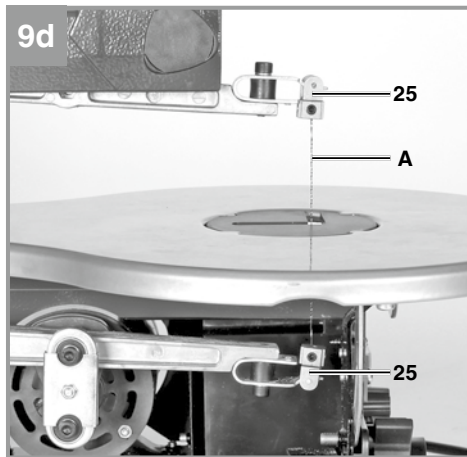



МАГАЗИН МАЙСТОРА®
БАШ ПРОФЕСИОНАЛНИ РЕШЕНИЯ

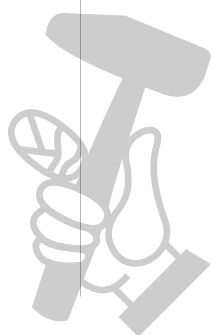

Danger!

When using the equipment, a few safety precautions must be observed to avoid injuries and damage. Please read the complete operating instructions and safety regulations with due care. Keep this manual in a safe place, so that the information is available at all times. If you give the equipment to any other person, hand over these operating instructions and safety regulations as well. We cannot accept any liability for damage or accidents which arise due to a failure to follow these instructions and the safety instructions.

Explanation of the symbols used (see Fig. 13)

1. **Danger!** - Read the operating instructions to reduce the risk of injury.
2. **Caution! Wear ear-muffs.** The impact of noise can cause damage to hearing.
3. **Caution! Wear a breathing mask.** Dust which is injurious to health can be generated when working on wood and other materials. Never use the device to work on any materials containing asbestos!
4. **Caution! Wear safety goggles.** Sparks generated during working or splinters, chips and dust emitted by the device can cause loss of sight.

1. Safety regulations

The corresponding safety information can be found in the enclosed booklet.

Warning!

Read all the safety information, instructions, illustrations and technical data provided on or with this power tool. Failure to adhere to the following instructions may result in electric shock, fire and/or serious injury.

Keep all the safety information and instructions in a safe place for future use.

2. Layout and items supplied**2.1 Layout (Fig. 1-12)**

1. Mounting holes
2. On/Off switch
3. Stroke speed controller
4. Pinned fretsaw blade
5. Angle scale
6. Pointer
7. Locking screw
8. Saw table

9. Table insert
10. Top blade holder
11. Bottom blade holder
12. Socket head screw 4 mm
13. Blade guard
14. Retaining bolt
15. Locking grip
16. Workpiece hold-down device
17. Socket head screw for hold-down device
18. Lateral cover
19. Recessed head screw
20. Tensioning screw
21. Articulated hose
22. Nozzle on the articulated hose
23. Arm
24. Pendulum arm
25. Adapter for a coping blade
26. Grub screw in the adapter
27. Extractor adapter
28. 2.5 mm hex key
29. 4 mm hex key
30. Spare pinned fretsaw blade

2.2 Items supplied

Please check that the article is complete as specified in the scope of delivery. If parts are missing, please contact our service center or the nearest branch of the DIY store where you made your purchase at the latest within 5 work days after purchasing the article and upon presentation of a valid bill of purchase. Also, refer to the warranty table in the warranty provisions at the end of the operating instructions.

- Open the packaging and take out the equipment with care.
- Remove the packaging material and any packaging and/or transportation braces (if available).
- Check to see if all items are supplied.
- Inspect the equipment and accessories for transport damage.
- If possible, please keep the packaging until the end of the guarantee period.

Danger!

The equipment and packaging material are not toys. Do not let children play with plastic bags, foils or small parts. There is a danger of swallowing or suffocating!

- Scroll Saw
- Blade guard, retaining bolt, workpiece hold-down device
- Articulated hose
- Adapter for a coping blade (2x)

- Extractor adapter
- 2.5 mm hex key
- 4 mm hex key
- Spare pinned fretsaw blade
- Original Operating Instructions
- Safety Information

3. Proper use

The fretsaw is intended for cutting square-edged timber or wood-like workpieces. Round materials may only be cut with suitable holding devices.

The machine is to be used only for its prescribed purpose. Any other use is deemed to be a case of misuse. The user / operator and not the manufacturer will be liable for any damage or injuries of any kind caused as a result of this.

Please note that our equipment has not been designed for use in commercial, trade or industrial applications. Our warranty will be voided if the machine is used in commercial, trade or industrial businesses or for equivalent purposes.

The equipment is to be operated only with suitable saw blades. It is prohibited to use any type of cutting-off wheel. To use the equipment properly you must also observe the safety regulations, the assembly instructions and the operating instructions to be found in this manual.

All persons who use and service the equipment have to be acquainted with this manual and must be informed about the machine's potential hazards.

It is also imperative to observe the accident prevention regulations in force in your area.

The same applies for the general rules of health and safety at work.

The manufacturer will not be liable for any changes made to the machine nor for any damage resulting from such changes.

Even when the equipment is used as prescribed it is still impossible to eliminate certain residual risk factors. The following hazards may arise in connection with the machine's construction and design:

- Harmful emissions of wood dust when used in closed rooms.
- Contact with the blade in the uncovered cutting zone.
- Injuries (cuts) when changing the blade.

- Crushed fingers.
- Kickback.
- Tilting of the workpiece due to inadequate support.
- Touching the blade.

This appliance is not intended for use by persons (including children) with reduced physical, sensory or mental capabilities, or lack of experience and knowledge, unless they have been given supervision or instruction concerning use of the appliance by a person responsible for their safety. Children should be supervised to ensure that they do not play with the appliance.

4. Technical data

AC motor:	230 V~ 50 Hz
Power consumption:	S1 70 W - S6 30% 120 W
Idle speed n_0 :	400-1600 min ⁻¹
Stroke:	14 mm
Tilting range of table:	-2° to 47°
Table size:	415 x 250 mm
Blade distance from the lateral pins:	127 mm
Tooth pitch in teeth per 25.4mm:	15 tpi (teeth per inch)
Throat:	406 mm
Max. cutting height at 90°:	50 mm
Max. cutting height at 45°:	23 mm
Dust extraction connector:	36 mm
Weight:	approx. 9 kg
Permitted length of a coping blade:	128-134 mm

Operating mode S6 30%: Continuous operation with idling (cycle time 10 minutes). To ensure that the motor does not become excessively hot, it may only be operated for 30% of the cycle at the specified rating and must then be allowed to idle for 70% of the cycle.

Danger!

Noise

The noise emission values were measured in accordance with EN 62841.

Operation

L_{pA} sound pressure level	71 dB(A)
K_{pA} uncertainty	3 dB(A)
L_{WA} sound power level	84 dB(A)
K_{WA} uncertainty	3 dB(A)

Wear ear-muffs.

The impact of noise can cause damage to hearing.

The stated noise emission values were measured in accordance with a set of standardized criteria and can be used to compare one power tool with another.

The stated noise emission values can also be used to make an initial assessment of exposure.

Warning:

The noise emission levels may vary from the level specified during actual use, depending on the way in which the power tool is used, especially the type of workpiece it is used for.

Keep the noise emissions and vibrations to a minimum.

- Only use appliances which are in perfect working order.
- Service and clean the appliance regularly.
- Adapt your working style to suit the appliance.
- Do not overload the appliance.
- Have the appliance serviced whenever necessary.
- Switch the appliance off when it is not in use.

Limit the operating time!

All stages of the operating cycle must be considered (for example, times in which the electric tools are switched off and times in which the tool is switched on but operates without load).

Caution!**Residual risks**

Even if you use this electric power tool in accordance with instructions, certain residual risks cannot be ruled out. The following hazards may arise in connection with the equipment's construction and layout:

1. Lung damage if no suitable protective dust mask is used.
2. Damage to hearing if no suitable ear protection is used.

5. Before using the tool**5.1 General information**

- All covers and safety devices must be properly fitted before the machine is switched on.
- It must be possible for the blade to run freely.
- When working with wood that has been previously processed, watch out for foreign bodies such as nails or screws, etc.
- Before you actuate the On/Off switch, make sure that the blade is correctly fitted and that the machine's moving parts run smoothly.
- Check that the voltage on the rating plate is the same as your supply voltage before you connect the machine to the power supply.

Warning!

Always pull out the power plug before carrying out any maintenance or conversion work on the fretsaw.

5.2 Setting up the machine (Fig. 4)

For greater stability you can use the 4 mounting holes (1) to fasten the machine to a workbench or similar. Suitable fastening materials such as screws etc. are available from your dealer.

5.3 Fitting the safety devices (Fig. 5)

- Remove the hold-down device (16) from the retaining bolt (14). To do so, use the hex key (29) to undo the socket head screw (17).
- Push the retaining bolt (14) into the mount on the arm (23). Then secure it with the locking grip (15).
- Fit the hold-down device (16) back on the retaining bolt (14) by tightening the socket head screw (17) with the hex key (29).
- **Warning!** The blade guard (13) must always be in the flipped-down position during operation.
- **Important!** You can adjust the height of the workpiece hold-down device (16) with the locking grip (15).
- **Warning!** Each time before you make a cut, adjust the hold-down device to the thickness of the workpiece (see Fig. 5d).
- The hold-down device (16) must be set far enough downwards so that it touches the workpiece during cutting.

5.4 Fitting the blow-clean and extraction system (Fig. 1/3)

- Plug the articulated hose (21) onto the connection on the arm (23).

- During operation, air will flow out of the nozzle (22) on the articulated hose (21) so that you can keep the markings on the workpiece free of wood sawings.
- Fit the extractor adapter (27) to the front of the machine.
- Now you can connect e.g. a wet & dry vac (not included with this product) to the extractor adapter (27). (Diameter information can be found in section 4. Technical data)

5.5 Changing a pinned fretsaw blade (Fig. 6)

- Wear work gloves to prevent injury when changing the blade!
- Remove the hold-down device (16) and the blade guard (13) as described in 5.3.
- Slacken the pinned fretsaw blade (4) by turning the tightening screw (20) as far as possible clockwise.
- First take the pinned fretsaw blade (4) out of the top blade holder (10). As you do so, press down the top pendulum arm (24).
- Then take the pinned fretsaw blade (4) out of the bottom blade holder (11).
- Pull the pinned fretsaw blade (4) up and out through the table insert (9).
- Insert the new pinned fretsaw blade in reverse order.
- The lateral pins on the blade (4) must lie in the recesses provided in the top (10) and bottom blade holder (11).
- **Caution!** The cutting direction of the pinned fretsaw blade (4) must point downwards, i.e. the cutting angle of the teeth must point from the top blade holder (10) to the bottom holder (11).
- Tension the new pinned fretsaw blade (4) by turning the tensioning screw (20) counterclockwise.
- The correct blade tension can be tested by applying pressure to the side of the blade with your finger at a point approximately half way between the two blade holders (10, 11). Rule of thumb: You should be able to bend the blade (4) only very slightly (approx. 1-2 mm).
- When the blade is tensioned enough, it will produce a metallic sound when tapped.
- Fit the hold-down device (16) and the blade guard (13) as described in 5.3.
- **Warning!** Each time after the blade is changed, check that the pinned fretsaw blade (4) runs freely in the table insert (9) when set to perpendicular position and also when it is set to 45° with the saw table (8) tilted.

5.6 Fitting a coping blade (Fig. 7-9)

You can also use commercially available coping blades (A) with this machine.

Important! There is no coping blade (A) supplied with this product.

- Remove the lateral cover (18) by undoing the 3 recessed head screws (19). (There is no crosstip screwdriver supplied with this product.)
- Remove the blade as described in 5.5.
- Press the table insert (9) from underneath so that it comes out of the saw table (8).
- Turn the table insert (9) counterclockwise through 90° (see Fig. 8c).
- Press the table insert (9) back into saw table (8). The table insert should make an audible click when it latches in place.
- **Important!** Commercially available coping blades (A) usually have fine saw teeth. It is **important** therefore to make sure that the angle of the teeth points downwards.
- Now insert the bottom end of the coping blade (A) into one of the adapters. **Important!** To be able to hook the adapter (25) on the blade holders (10, 11), the coping blade (A) is not allowed to project out of the adapter (25).
- Fasten the coping blade (A) in the adapter (25) by tightening the grub screws (26) with the hex key (28).
- Pass the coping blade (A) through the table insert (9) from underneath and hook the adapter (25) in the bottom blade holder (11).
- Fasten the top end of the coping blade (A) to the second adapter (25) and hook it on the top blade holder (10). As you do so, press down the top pendulum arm (24).
- The correct tension of the coping blade (A) is the same as that of a pinned fretsaw blade (4) as described in 5.5.
- Fit the lateral cover (18).
- To change over to a pinned fretsaw blade (4), proceed in reverse order.

5.7 Setting the saw table at an angle (Fig. 10)

- Use the locking grip (15) to set the hold-down device (16) to the maximum height.
- Undo the locking screw (7).
- Tilt the saw table (8) to the left until the pointer (6) points to the required angle on the dial scale (5).
- Set the hold-down device (16) to the matching height for the thickness of the workpiece and secure the setting with the locking grip (15).

5.8 Precision adjustment of the blade angle (Fig. 11)

Important! For a straight cut you must make sure that the angle between the blade (4 or A) and the saw table (8) corresponds with what is indicated on the angle scale (5).

- Set the saw table (8) to the dimension 0° and secure it with the locking screw (7).
- Use a 90° angle stop (B) to check the angle between the blade (4 or A) and the saw table (8).
- There is no 90° angle stop (B) supplied with this product.
- Depending on the deviation you can adjust the blade angle at the top blade holder (10) as well as at the bottom blade holder (11).
- To adjust the top blade holder (10), use the hex key (29) to slacken the socket head screw (12).
- Now you can adjust the top blade holder (10) until the angle between the blade (4 or A) and the saw table (8) equals exactly 90°. Then use the hex key (29) again to retighten the socket head screw (12).
- To adjust the bottom blade holder (11), first remove the lateral cover (18) as described in 5.6 (see Fig. 7).
- Use the hex key (29) to slacken the socket head screw (12) on the bottom blade holder (11).
- Turn the bottom blade holder (11) until the angle between the blade (4 or A) and the saw table (8) equals exactly 90°, then retighten the socket head screw (12).
- Fit the lateral cover (18).

6. Operation

Warning!

- After every new adjustment we recommend you to make a trial cut in order to check the new settings.
- After switching on the saw, wait for the blade to reach its maximum speed of rotation before commencing with the cut.
- Take extra care when starting the cut!
- Never use the machine without the suction function.
- Regularly check and clean the suction channels.
- Take special care to avoid the blade from bending or twisting while you are cutting thick timber. This will help to prolong the blade's

working life.

- **Important!** The teeth cut the timber only on their upward stroke.

6.1 On/Off switch (Fig. 3/Item 2)

- To switch on, press the green button „I“.
- To switch off you must press the red button „0“.

6.2 Stroke speed controller (Fig. 3)

You can use the stroke speed controller (3) to set the stroke speed to match the material you want to cut.

6.3 Making a cut (Fig. 12)

- **Warning!** Set the hold-down device (16) to the matching height for the thickness of the workpiece and secure the setting with the locking grip (15).
- Swing down the blade guard (13).
- Switch on the saw (see 6.1).
- Place your hands (with fingers closed) flat on the workpiece and press the workpiece downwards against the saw table (8).
- Push the workpiece slowly into the blade (4 or A).
- If you don't push the workpiece fully through the blade (4 or A), switch off the machine and wait until the blade has come to a standstill. Only then are you allowed to pull out the workpiece from the blade.
- The offcut piece will remain on the saw table (8) until the blade (4 or A) is back in its position of rest.

6.4 Making an inside cut

A special feature of this fretsaw is that you can use it to make cuts inside a workpiece without damaging the outside or the circumference of the workpiece.

Warning: To avoid injury from accidental starting: Before you remove or change the blade, always set the switch to „0“ position and pull the power plug out of the socket.

1. How to carry out inside cuts in a workpiece: Remove the blade as described in 5.5 and 5.6.
2. Drill a hole in the workpiece in question.
3. Place the workpiece on the saw table so that the drilled hole lies over the table insert.
4. Fit the blade through the drilled hole in the workpiece and tension it.
5. When you have completed the inside cuts,

remove the blade from the blade holders (as described in sections 5.5 and 5.6) and remove the workpiece from the table.

6. Refit and tension the blade as described in sections 5.5 and 5.6.

7. Replacing the power cable

Danger!

If the power cable for this equipment is damaged, it must be replaced by the manufacturer or its after-sales service or similarly trained personnel to avoid danger.

8. Cleaning, maintenance and ordering of spare parts

Danger!

Always pull out the mains power plug before starting any cleaning work.

8.1 Cleaning

- Keep all safety devices, air vents and the motor housing free of dirt and dust as far as possible. Wipe the equipment with a clean cloth or blow it with compressed air at low pressure.
- We recommend that you clean the device immediately each time you have finished using it.
- Clean the equipment regularly with a moist cloth and some soft soap. Do **not** use cleaning agents or solvents; these could attack the plastic parts of the equipment. Ensure that no water can seep into the device.

8.2 Carbon brushes

In case of excessive sparking, have the carbon brushes checked only by a qualified electrician.

Important! The carbon brushes should not be replaced by anyone but a qualified electrician.

8.3 Maintenance

There are no parts inside the equipment which require additional maintenance.

8.4 Ordering replacement parts:

Please quote the following data when ordering replacement parts:

- Type of machine
- Article number of the machine
- Identification number of the machine
- Replacement part number of the part required

For our latest prices and information please go to www.Einhell-Service.com

9. Disposal and recycling

The unit is supplied in packaging to prevent its being damaged in transit. This packaging is raw material and can therefore be reused or can be returned to the raw material system.

The unit and its accessories are made of various types of material, such as metal and plastic. Defective components must be disposed of as special waste. Ask your dealer or your local council.

10. Storage

Store the equipment and accessories out of children's reach in a dark and dry place at above freezing temperature. The ideal storage temperature is between 5 and 30 °C. Store the electric tool in its original packaging.

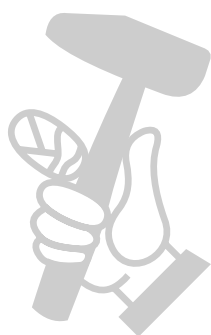



For EU countries only

Never place any electric power tools in your household refuse.

To comply with European Directive 2012/19/EC concerning old electric and electronic equipment and its implementation in national laws, old electric power tools have to be separated from other waste and disposed of in an environment-friendly fashion, e.g. by taking to a recycling depot.

Recycling alternative to the return request:

As an alternative to returning the equipment to the manufacturer, the owner of the electrical equipment must make sure that the equipment is properly disposed of if he no longer wants to keep the equipment. The old equipment can be returned to a suitable collection point that will dispose of the equipment in accordance with the national recycling and waste disposal regulations. This does not apply to any accessories or aids without electrical components supplied with the old equipment.

Please note that batteries and lamps (e.g. light bulbs) must be removed from the tool before it is disposed of.

The reprinting or reproduction by any other means, in whole or in part, of documentation and papers accompanying products is permitted only with the express consent of the Einhell Germany AG.

Subject to technical changes



Service information

We have competent service partners in all countries named on the guarantee certificate whose contact details can also be found on the guarantee certificate. These partners will help you with all service requests such as repairs, spare and wearing part orders or the purchase of consumables.

Please note that the following parts of this product are subject to normal or natural wear and that the following parts are therefore also required for use as consumables.

Category	Example
Wear parts*	Table insert
Consumables*	Saw blade
Missing parts	

* Not necessarily included in the scope of delivery!

In the effect of defects or faults, please register the problem on the internet at www.Einhell-Service.com. Please ensure that you provide a precise description of the problem and answer the following questions in all cases:

- Did the equipment work at all or was it defective from the beginning?
- Did you notice anything (symptom or defect) prior to the failure?
- What malfunction does the equipment have in your opinion (main symptom)? Describe this malfunction.



Warranty certificate

Dear Customer,

All of our products undergo strict quality checks to ensure that they reach you in perfect condition. In the unlikely event that this equipment develops a fault, please contact our service department at the address shown on this guarantee card. You can also contact us by telephone using the service number shown. Please note the following terms under which guarantee claims can be made:

1. These guarantee terms apply solely to consumers, i.e. natural persons, who do not want to use this product in connection with either their commercial or other self-employed activities. These guarantee terms regulate additional guarantee services which the undermentioned manufacturer promises to buyers of its new products in addition to their statutory rights of guarantee. Your statutory rights of guarantee are not affected by this guarantee. Our guarantee is free of charge to you.
2. The guarantee services cover only defects due to material or manufacturing faults on the new product which you have bought in the European Union from the undermentioned manufacturer and are limited to either the rectification of said defects or the replacement of the product, whichever we prefer. Please note that only equipment under the brand name "Professional" has been designed for use in commercial, trade or professional applications. For all other products the guarantee is invalidated if the equipment is used within the guarantee period in commercial, trade or industrial applications or for other equivalent activities.
3. Our guarantee does not cover:
 - Damage to the equipment caused by failure to comply with the installation/assembly instructions or by unprofessional installation; damage caused by failure to comply with the operating instructions (e.g. connection to the wrong mains voltage or current type); damage caused by failure to comply with the maintenance and safety regulations; damage caused by exposing the equipment to abnormal environmental conditions; damage resulting from poor care and maintenance.
 - Damage to the equipment caused by misuse or incorrect applications (e.g. overloading the equipment or using non-approved attachments or accessories); damage caused by foreign bodies (e.g. sand, stones, dust, ...) getting inside the equipment. Damage in transit; damage caused by force or external influences (e.g. by dropping the equipment).
 - Damage to the equipment or parts of the equipment which is owed to use-related, normal or otherwise natural wear. For example, batteries and battery packs are manufactured with a cycle limit for design-related reasons. Wear is negatively influenced in particular by load demands and charging speeds as well as exposure to heat, cold, vibration and impact.
4. The guarantee is valid for a period of 2 years starting from the purchase date of the equipment. Guarantee claims must be submitted before the end of the guarantee period and within two weeks of the defect being noticed. No guarantee claims will be accepted after the end of the guarantee period. The original guarantee period remains applicable to the equipment even if repairs are carried out or parts are replaced. In such cases, the work performed or parts fitted will not result in an extension of the guarantee period, and no new guarantee will become active for the work performed or for any replacement parts fitted. This also applies if on-site service is used.
5. To assert your guarantee claim, register the defective equipment at: www.Einhell-Service.com. You will need to provide proof of purchase of the new item of equipment. Equipment returned without such proof or without a rating plate are excluded from the guarantee services because of the lack of traceability. If the defect is covered by our guarantee, then either the item in question will be repaired immediately and returned to you or we will send you a new replacement.
6. If you have taken the equipment with you to a different EU country than where you bought it, we will arrange for a local service partner to provide the guarantee services. If you take the equipment outside the EU, the guarantee will not apply.

Of course, we are also happy to offer a chargeable repair service for any defects which are not covered or no longer covered by the scope of this guarantee. To take advantage of this service, please send the equipment to our service address. We draw attention to the restrictions of this guarantee concerning wear parts, consumables and missing parts as presented in the service information included in this operating manual.

Warrantor/ Service:

Einhell UK Ltd, Unit 10, 1st Floor, Champion's Business Park, Arrowe Brook Road, Upton, Wirral, CH49 0UQ