

metabo®

PROFESSIONAL POWER TOOL SOLUTIONS

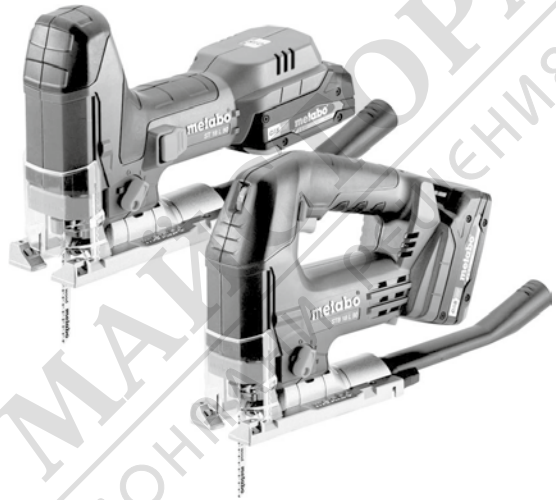

ST 18 L 90
STB 18 L 90





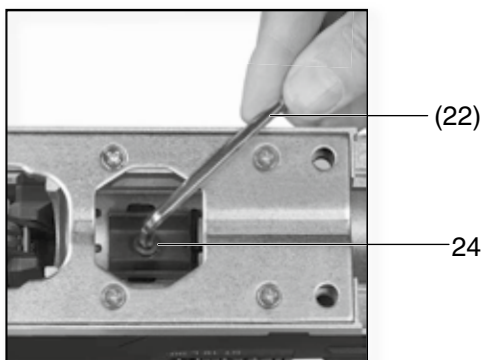
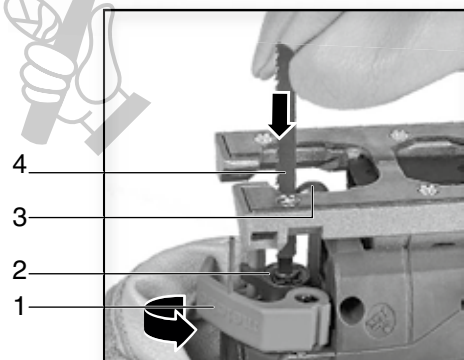
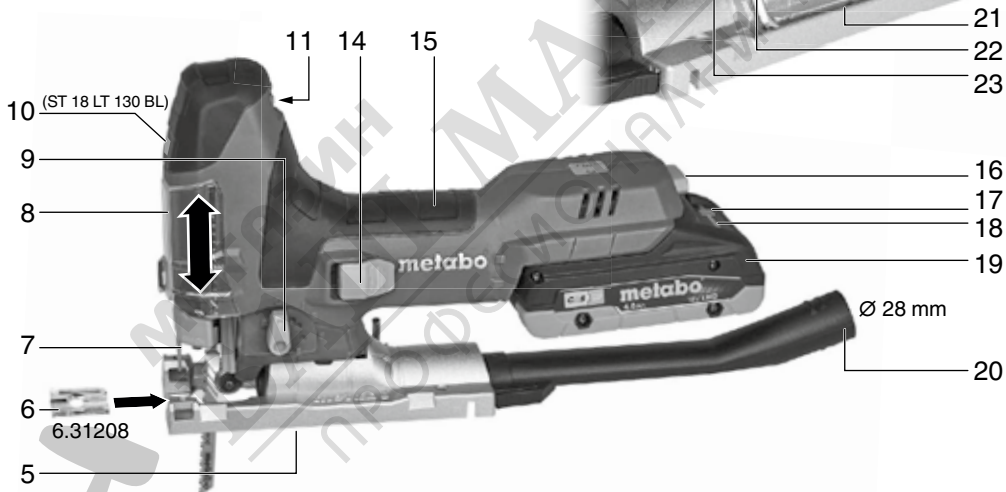

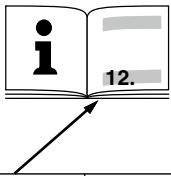



ST 18 LT 130 BL
STB 18 LT 130 BL













de	Originalbetriebsanleitung 5	fi	Alkuperäiset ohjeet 43
en	Original instructions 10	no	Original bruksanvisning 47
fr	Notice originale 14	da	Original brugsanvisning 51
nl	Oorspronkelijke gebruiksaanwijzing 19	pl	Instrukcja oryginalna 55
it	Istruzioni originali 24	el	Πρωτότυπο οδηγιών χρήσης 60
es	Manual original 29	hu	Eredeti használati utasítás 65
pt	Manual de instruções original 34	ru	Оригинальное руководство по эксплуатации 70
sv	Bruksanvisning i original 39	uk	Оригінальна інструкція з експлуатації 76



		ST 18 L 90 *) Serial-Number: 01047..	STB 18 L 90 *) Serial-Number: 01048..	ST 18 LT 130 BL *) Serial-Number: 01054..	STB 18 LT 130 BL *) Serial-Number: 01055..
U	V	18	18	18	18
 T₁	mm (in)	90 (3 ⁹ / ₁₆)	90 (3 ⁹ / ₁₆)	130 (5 ¹ / ₈)	130 (5 ¹ / ₈)
T₂	mm (in)	25 (1)	25 (1)	35 (1 ³ / ₈)	35 (1 ³ / ₈)
T₃	mm (in)	10 (³ / ₈)	10 (³ / ₈)	10 (³ / ₈)	10 (³ / ₈)
n₀	min ⁻¹ (rpm)	750 - 3000	700 - 3000	1000 - 3500	0 - 3500
m	kg (lbs)	2,2 (4.9)	2,3 (5.1)	2,1 (4.6)	2,2 (4.9)
a_{h,CM}/K_{h,CM}	m/s ²	8,7 / 1,5	6,3 / 1,5	11,3 / 1,5	7,5 / 1,5
a_{h,CW}/K_{h,CW}	m/s ²	7,6 / 1,5	4,0 / 1,5	8,7 / 1,5	4,9 / 1,5
L_{pA}/K_{pA}	dB(A)	86,9 / 5	87,3 / 5	90 / 5	90 / 5
L_{WA}/K_{WA}	dB(A)	94,9 / 5	95,3 / 5	98 / 5	98 / 5

	
I - III	
0 - III	
0 - III	
0 - II	
I - II	
0	
0 - I	
0 - I	
0	

	
6	
6	
5-6	
3-4	
4-6	
2-4	
3-5	
3-4	
5-6	



*2) 2014/30/EU, 2006/42/EC, 2011/65/EU

*3) EN 62841-1:2015, EN 62841-2-11:2016+A1:2020, EN IEC 63000:2018

2023-08-10, Bernd Fleischmann
 Direktor Produktentstehung & Qualität (Vice President Product Engineering & Quality)

*4) Metabowerke GmbH - Metabo-Allee 1 - 72622 Nuertingen, Germany

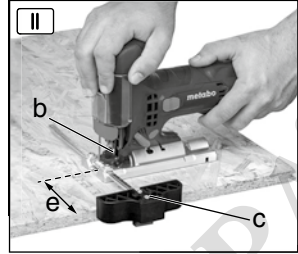
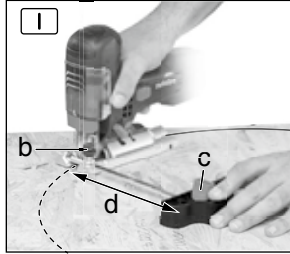
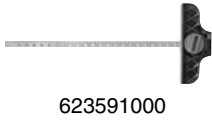
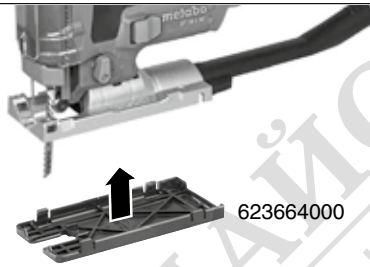
A**B****C**

ASC 55



ASC 145

etc.

**D**

18 V	2,0 Ah	625026000
18 V	4,0 Ah	625367000
		etc.

Li-Power
LiHD



Original instructions

1. Declaration of Conformity

We, being solely responsible, hereby declare that these jig saws, identified by type and serial number *1), meet all relevant requirements of directives *2) and standards *3). Technical documents for *4) - see page 3.

For UK only:

UK We as manufacturer and authorized person to **CA** compile the technical file, see *4) on page 3, hereby declare under sole responsibility that these jig saws, identified by type and serial number *1) on page 3, fulfill all relevant provisions of following UK Regulations S.I. 2016/1091, S.I. 2008/1597, S.I. 2012/3032 and Designated Standards see *3) on page 3.

2. Specified Conditions of Use

The machine is suitable for sawing non-ferrous metals and sheet steel, wood and similar materials, plastics and similar materials. Any other use is not permitted.

The user bears sole responsibility for any damage caused by inappropriate use.

Generally accepted accident prevention regulations and the enclosed safety information must be observed.

3. General Safety Information



For your own protection and for the protection of your power tool, pay attention to all parts of the text that are marked with this symbol!



WARNING – Read the operating instructions to reduce the risk of injury.



WARNING – Read all safety warnings, instructions, illustrations and specifications provided with this power tool. Failure to follow all instructions listed below may result in electric shock, fire and/or serious injury.

Save all warnings and instructions for future reference.

Always include these documents when passing on your power tool.

4. Special Safety Instructions

Hold the power tool by insulated gripping surfaces, when performing an operation where the cutting accessory may contact hidden wiring. Cutting accessory contacting a “live” wire may make exposed metal parts of the power tool “live” and could give the operator an electric shock.

Use clamps or another practical way to secure and support the workpiece to a stable platform.

Holding the work by your hand or against the body leaves it unstable and may lead to loss of control.

Ensure that the place where you wish to work is free of power cables, gas lines or water pipes (e.g. check using a metal detector).

Do not try to saw extremely small workpieces.

When sawing, the footplate must make secure contact with the workpiece.

When interrupting a cut for any reason, release the trigger and hold the saw motionless in the material until the saw blade comes to a complete stop. Never attempt to remove the saw from the workpiece while the saw blade is in motion or kickback may occur.

Do not switch the machine on while the saw blade is touching the workpiece. Let the saw blade reach full speed before making a cut.

When restarting a saw in the workpiece, centre the saw blade in the kerf so that the saw teeth are not engaged into the material. If the saw blade seizes, it may kickback from the workpiece when the saw is restarted.

Keep hands well away from the sawing area and the saw blade. Do not reach underneath the workpiece.

Remove chips and similar material only with the machine at a standstill.

Danger of injury due to the sharp jigsaw blade. After stopping work, the jigsaw blade may still be hot. Wear protective gloves.

Remove the battery pack from the machine before making any adjustments, changing tools, maintaining or cleaning.

Before fitting the battery pack, make sure that the machine is switched off.

Remove the battery pack from the machine when not in use.

LED light: do not observe the LED radiation directly with optical instruments.



CAUTION Do not stare at operating lamp.



Protect battery packs from water and moisture!



Do not expose battery packs to fire!



Do not use faulty or deformed battery packs!

Do not open battery packs!

Do not touch or short circuit battery pack contacts!



A slightly acidic, flammable fluid may leak from defective Li-Ion battery packs!



If battery fluid leaks out and comes into contact with your skin, rinse immediately with plenty of water. If battery fluid leaks out and comes into contact with your eyes, wash them with clean water and seek medical attention immediately!

If the machine is defective, remove the battery pack from the machine.

Reducing dust exposure:

 **WARNING** - Some dust created by power sanding, sawing, grinding, drilling, and other construction activities contains chemicals known to cause cancer, birth defects or other reproductive harm. Some examples of these chemicals are:

- Lead from lead-based paints,
- crystalline silica from bricks and cement and other masonry products, and
- arsenic and chromium from chemically treated lumber.

Your risk from these exposures varies, depending on how often you do this type of work. To reduce your exposure to these chemicals, work in a well-ventilated area, and work with approved safety equipment, such as those dust masks that are specially designed to filter out microscopic particles.

This also applies to dust from other materials, such as some timber types (like oak or beech dust), metals, asbestos. Other known diseases are e.g. allergic reactions, respiratory diseases. Do not let dust enter the body.

Observe the relevant guidelines and national regulations for your material, staff, application and place of application (e.g. occupational health and safety regulations, disposal).

Collect the particles generated at the source, avoid deposits in the surrounding area.

Use suitable accessories for special work. In this way, fewer particles enter the environment in an uncontrolled manner.

Use a suitable extraction unit.

Reduce dust exposure with the following measures:

- do not direct the escaping particles and the exhaust air stream towards yourself or nearby persons or towards dust deposits,
- use an extraction unit and/or an air purifier,
- ensure good ventilation of the workplace and keep it clean using a vacuum cleaner. Sweeping or blowing stirs up dust.
- Vacuum or wash protective clothing. Do not blow, beat or brush protective gear.

Transport of Li-Ion battery packs:

The shipping of Li-Ion battery packs is subject to laws related to the carriage of hazardous goods (UN 3480 and UN 3481). Inform yourself of the currently valid specifications when shipping Li-Ion battery packs. If necessary, consult your freight forwarder. Certified packaging is available from Metabo.

- Only send the battery pack if the housing is intact and no fluid is leaking. Remove the battery pack from the machine for sending. Prevent the contacts from short-circuiting (e.g. by protecting them with adhesive tape).

5. Overview

See page 2. The illustrations are regarded as exemplary for all devices.

- 1 Clamping lever for securing the saw blade
- 2 Saw blade clamping fixture
- 3 Saw blade support roller

- 4 Saw blade *
 - 5 Footplate
 - 6 Anti-splintering footplate insert*
 - 7 Protective rod for preventing unintentional contact with the saw blade
 - 8 Protective cap
 - 9 Adjustment lever for pendulum motion
 - 10 Button for switching the automatically activated LED light off and on *
 - 11 Setting wheel for speed adjustment
 - 12 Lock button (continuous operation)*
 - 13 Trigger switch *
 - 14 Slide switch
 - 15 Handle
 - 16 Battery pack release button
 - 17 Capacity indicator button *
 - 18 Capacity and signal indicator *
 - 19 Battery pack *
 - 20 Extractor connection piece *
 - 21 Wrench depot
 - 22 Hexagon spanner
 - 23 Curved support plate indicating preset cutting angle
 - 24 Screw for adjusting the footplate
- * depending on equipment/not in scope of delivery / depending on the model

6. Initial Operation**6.1 Battery pack**

Charge the battery pack (19) before use.

Recharge the battery pack if performance diminishes.

Instructions on charging the battery pack can be found in the operating instructions of the Metabo charger.

Battery packs have a capacity and signal indicator (18) (depends on design variant):

- Press the button (17), the LEDs indicate the charge level.
- The battery pack is almost empty and must be recharged if one LED is flashing.

6.2 Removing and inserting the battery pack**Removing:**

Press the battery pack release (16) button and remove the battery pack (19).

Inserting:

Slide in the battery pack (19) until it engages.

6.3 Fitting the anti-splintering footplate insert

 Danger of injury due to the sharp jigsaw blade. Remove the saw blade before fitting the anti-splintering footplate insert (6).

Turn the machine over so that the footplate faces upwards. Insert the anti-splintering footplate from the front, while noting the following 2 items:

- The smooth side of the footplate points upward.
- The slot is facing to the rear (towards the battery pack).

If you wish to work with the protective plate attached (see chapter Accessories 9.), insert the anti-splintering footplate insert in the protective plate.

6.4 Inserting the saw blade

 Danger of injury due to the sharp jigsaw blade. After stopping work, the jigsaw blade may still be hot. Wear protective gloves.

Use a saw blade that is suitable for the material being sawn.

- Turn the clamping lever (1) forwards to the stop and hold in place.
- Insert the saw blade (4) up to the stop. Ensure that the saw teeth are facing forwards and the blade is seated correctly in the groove on the saw blade support roller (3).
- Release the clamping lever (1). (It returns to its initial position by itself. The saw blade is now securely tightened).

6.5 Removing the saw blade

 Caution: Be careful not to point the jigsaw at anyone when removing it.

- Turn the clamping lever (1) forward until the stop; the saw blade is ejected as a result of spring force.

6.6 Sawing with dust extraction

- Fit the extractor connection piece (20). Connect a suitable extraction device.
- For optimum dust extraction performance, push the protective cap (8) downward.

6.7 Sawing without dust extraction

- Work with the protective cap (8) pushed up.

6.8 Diagonal cuts

Push the protective cap (8) upwards, remove the anti-splintering footplate (6). These parts cannot be used for diagonal cuts.

- Slacken the screw (24).
- Slid the footplate (5) forwards slightly and turn.
- Subsequently, push the footplate (5) back again to the back and turn until it stops at one of the 45° stops.
- Adjust to different angles using an angle gage.
- Tighten the screw (24) again.

7. Use

7.1 Adjusting the pendulum motion

Set the required pendulum motion using the adjustment lever (9).

Position "0" = pendulum motion is switched off

Position "III" = maximum pendulum motion

See page 3 for recommend setting values.

The best way to determine the ideal setting is through a practical trial.

7.2 Setting maximum speed

Set the machine to maximum speed using the setting wheel (11). This can also be done during operation.

See page 3 for recommend setting values.

The best way to determine the ideal setting is through a practical trial.

7.3 Switching On/Off, continuous operation (ST 18 L 90)

 Avoid inadvertent starts: always switch the tool off when the plug is removed from the mains socket or if there has been a power cut.

 In continuous operation, the machine continues running if it is forced out of your hands. Therefore, always hold the machine with both hands using the handle provided, stand securely and concentrate.

Switching on: push the slide switch (14) forwards. For continuous operation, tilt it downwards until it engages.

Switching off: press the rear end of the slide switch (14) and release it.

7.4 Switching On/Off, continuous operation (STB 18 L 90)

Switching on: Press the trigger switch (13).

Switching off: Release trigger switch (13).

Continuous activation: With the trigger (13) pressed, push in the locking button (12) and release the trigger (13). Press and release the trigger (13) again to switch off.

 In continuous operation, the machine continues running if it is forced out of your hands. Therefore, always hold the machine with both hands using the handles provided, stand securely and concentrate.

8. Cleaning, Maintenance

Remove the battery pack from the machine before making any adjustments, changing tools, maintaining or cleaning.

Clean the machine regularly. This includes vacuum cleaning the ventilation louvres on the motor.

Clean the saw blade clamping fixture (2) regularly and thoroughly by blowing with compressed air.

If required, clean the openings behind the saw blade support roller (3) and the extraction nozzles (16).

Apply a drop of oil to the saw blade support roller (3) from time to time.

9. Accessories

Use only original Metabo or CAS (Cordless Alliance System) battery packs and accessories.

Use only accessories that fulfil the requirements and specifications listed in these operating instructions.

Fit accessories securely. If the machine is operated in a holder: secure the machine well. Loss of control can cause personal injury.

See page 4.

- A Circular-cutting and parallel guide
 - B Protective plate (prevents workpieces with sensitive surfaces from becoming scratched)
 - C Chargers
 - D Battery packs with different capacities.
- Buy battery packs only with voltage suitable for your power tool.

9.1 Attaching the circular-cutting and parallel guide

For sawing circles (dia. 100 - 360 mm) and making cuts parallel with edges (max. 210 mm).

Attach circular guide (see Fig. I)

- Slide the rod on the circular-cutting and parallel guide sideways into the footplate (centre point (c) faces downwards).
- Set the desired radius (d).
- Tighten screw (b).
- Turn the button in such a way that the rear centre point (c) in direction of sawing is extended. Insert it into the centre of the circle.

Attach parallel guide (see Fig. II)

- Slide the rod on the circular cutting and parallel guide sideways into the footplate (the centre point (c) faces upwards).
- Set the dimension (e)
- Tighten screw (b).

In order to minimise saw blade drifting, we recommend using extra-thick saw blades:

623694000, **623679000**, **623685000**

See www.metabo.com or the catalogue for a complete range of accessories.

10. Repairs

 Repairs to electrical tools must only be carried out by qualified electricians!

Contact your local Metabo representative if you have Metabo power tools requiring repairs. For addresses see www.metabo.com.

You can download a list of spare parts from www.metabo.com.

11. Environmental Protection

Observe national regulations on environmentally compatible disposal and on the recycling of disused machines, packaging and accessories.

Packaging materials must be disposed of according to their labelling in accordance with municipal guidelines. Further information can be found at www.metabo.com in the "Service" section.

Battery packs may not be disposed of with regular waste. Return faulty or used battery packs to your Metabo dealer!

Do not allow battery packs to come into contact with water!

 Only for EU countries: never dispose of power tools in your household waste!
According to European Directive 2012/19/EU on Waste from Electric and Electronic Equipment and implementation in national law, used power tools must be collected separately and recycled in an environmentally-friendly manner. Discharge the battery pack in the power tool before disposal. Prevent the contacts from short-circuiting (e.g. by protecting them with adhesive tape).

12. Technical Specifications

Explanatory notes regarding the specifications on page 3.

Subject to change in accordance with technical progress.

U	= Voltage of battery pack
T ₁	= Maximum material thickness in wood
T ₂	= Maximum material thickness in non-ferrous metals
T ₃	= Maximum material thickness in sheet steel
n ₀	= Stroke rate at idle speed
P ₁	= Rated input power
P ₂	= Power output
m	= Weight with smallest battery pack

Measured values determined in conformity with EN 62841.

Permitted ambient temperature during operation: -20 °C to 50 °C (limited performance with temperatures below 0 °C). Permitted ambient temperature for storage: 0 °C to 30 °C

--- direct current

The technical specifications quoted are subject to tolerances (in compliance with relevant valid standards).

Emission values

These values make it possible to assess the emissions from the power tool and to compare different power tools. The actual load may be higher or lower depending on operating conditions, the condition of the power tool or the accessories used. Please allow for breaks and periods when the load is lower for assessment purposes. Arrange protective measures for the user, such as organisational measures based on the adjusted estimates.

Vibration total value (vector sum of three directions) determined in accordance with EN 62841:

a _{h,CM}	= Vibration emission value (Sawing sheet metal)
a _{h,CW}	= Vibration emission value (Sawing wood)
K _{h,...}	= Uncertainty (vibration)

Typical A-effective perceived sound levels:

L _{pA}	= Sound pressure level
L _{WA}	= Acoustic power level
K _{pA} , K _{WA}	= Uncertainty

During operation the noise level can exceed 80 dB(A).

 **Wear ear protectors!**