



Husqvarna®



TC 215T, TC 220T

EN	Operator's manual	2-44
ES	Manual de usuario	45-88
PT	Manual do utilizador	89-133
IT	Manuale dell'operatore	134-177



МАГАЗИН МАЙСТРОВ
ПРОФЕСІОНАЛНИ РЕШЕНИЯ

Contents

Introduction.....	2	Troubleshooting.....	34
Safety.....	6	Transportation, storage and disposal.....	37
Assembly.....	12	Technical data.....	40
Operation.....	15	Service.....	42
Maintenance.....	20	Declaration of Conformity.....	43

Introduction

Pre-delivery inspection and product numbers

Note: A pre-delivery inspection has been done of this product. Make sure that you receive a signed copy of the pre-delivery inspection document from your dealer.

Service agent contact information:	
This operator's manual belongs to product with product number / serial number:	
	/
Engine:	
Transmission:	

Product description

This is a lawn tractor with the cutting deck installed between the front and rear axles. It has a 4-stroke engine that uses gasoline.

Intended use

This product is only used to cut grass in private gardens and on private garden slopes with not more than 10° slope. It is not to be used in public parks, sports grounds, in farming or in forestry. Attach an optional accessory to use the product for other tasks. Only use the product with accessories that are approved by the

manufacturer. Speak to an approved service agent for more information.

To use the product differently is incorrect use. It will void your warranty and reject the responsibility for damage to the user of third parties on the part of the manufacturer.

Refer to local directives for the operation of lawn mowers.

Insure your product

Make sure that you have insurance coverage for your new product. Speak to your insurance company if you are not sure. We recommend a fully comprehensive

insurance that includes third party, fire, damage, theft and liability.

Product overview

Product overview

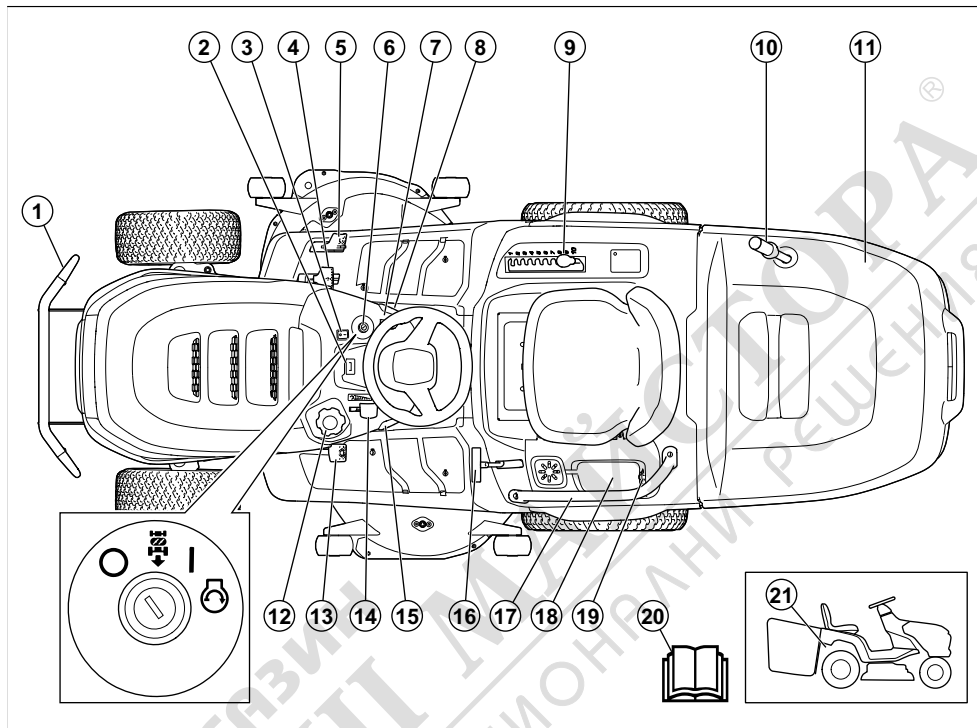

1. Front bumper (accessory for TC 215T)
2. Hour meter
3. Light switch
4. Forward pedal
5. Rearward pedal
6. Ignition lock
7. PTO button
8. Parking brake lock
9. Cutting height lever
10. Grass catcher handle
11. Grass catcher
12. Fuel tank cap
13. Parking brake pedal
14. Throttle control
15. Cruise control (TC 220T only)
16. Lock lever for the grass catcher
17. Handle (accessory for TC 215T)
18. Storage compartment and battery cover
19. Power outlet, 12 V
20. Operator's manual

21. Lever to engage or disengage the drive system

Husqvarna Connect

The operators manual and more information about the product is available at Husqvarna Connect App. Husqvarna Connect is a free App for your mobile device. Refer to *To start to use Husqvarna Connect on page 15*.

Operator Presence Control (OPC)

The OPC engages when the operator lifts from the seat. The engine stops if the parking brake is not applied. The blades stop if the blades are engaged. Refer to *Operation conditions on page 9*.

Grass catcher presence control

The product has a grass catcher presence control that engages when a grass catcher or other accessory is installed. The blades stop if the grass catcher or other accessory is removed. Refer to *Operation conditions on page 9*.

Headlight

The product has work light and high beam. Push the light switch to position (A) for high beam or position (B) for work light. Push the light switch to position (C) to make the headlight go off.

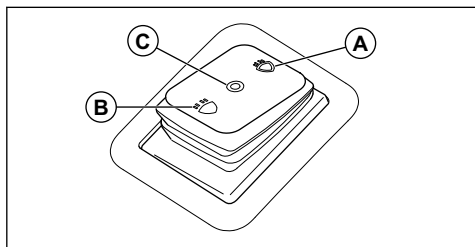

Symbols on the product



WARNING: This product can be dangerous and cause serious injury or death to the operator or others. Be careful and use the product correctly.



Read the operator's manual carefully and make sure that you understand the instructions before you use this product.



Fast



Slow



Engage the drive system.



Disengage the drive system.



Engine off



Engine on



Engine start



Parking brake pedal



Cutting height



Reverse operation system (ROS)



Reverse



Forward



Cruise control



Work light



High beam



Headlight off



Grass catcher locked



Grass catcher unlocked



Look behind you before and while you move the product in reverse.



Fuel



Never carry passengers on the product or equipment.



Max. ethanol 10%



Keep bystanders away.



Engine oil



No step



Use hearing protection.



Disconnect the spark plug cap before you do maintenance on the product.



The blades are disengaged.



MAX. XXXXN / (XXXkg)

Max. permitted vertical load on the towbar is specified in *Technical data on page 40* and on the label.



The blades are engaged.



MAX. XXXXN / (XXXkg)

Max. permitted horizontal load on the towbar is specified in *Technical data on page 40* and on the label.



Keep body parts away from rotating parts.



Noise emission to the environment label as per EU and UK directives and regulations, and New South Wales legislation "Protection of the Environment Operations (Noise Control) Regulation 2017". The guaranteed sound power level of the product is specified in *Technical data on page 40* and on the label.



Keep body parts away from rotating blades.



Look out for ejecting objects and ricochets.



Scannable code



Do not cut grass across a slope. Do not cut grass on ground that slopes more than 10°.



The product agrees with the applicable EC directives.



Tip-over hazard



This product conforms to the applicable UK regulations.

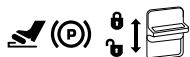

Apply and release the parking brake.

DANGER – Keep hands and feet away.

Hour meter

The hour meter shows how many hours the engine has been in operation. Refer to *Product overview on page 3* for the position of the hour meter.

Product damage

We are not responsible for damages to our product if:

- the product is incorrectly repaired.
- the product is repaired with parts that are not from the manufacturer or not approved by the manufacturer.
- the product has an accessory that is not from the manufacturer or not approved by the manufacturer.
- the product is not repaired at an approved service center or by an approved authority.

Euro V Emissions



WARNING: Tampering with the engine voids the EU type-approval of this product.

Note: Other symbols/decals on the product refer to market specific legal requirements.

Label on the product



Safety

Safety definitions

Warnings, cautions and notes are used to point out specially important parts of the manual.



WARNING: Used if there is a risk of injury or death for the operator or bystanders if the instructions in the manual are not obeyed.



CAUTION: Used if there is a risk of damage to the product, other materials or the adjacent area if the instructions in the manual are not obeyed.

Note: Used to give more information that is necessary in a given situation.

General safety instructions



WARNING: This product can cut off hands and feet and throw objects. Serious injury or death may occur if you do not obey the safety instructions.



WARNING: Do not continue to use a product with damaged cutting equipment. Damaged cutting equipment can throw

objects and cause serious injury or death. Replace damaged blades immediately.



WARNING: This product produces an electromagnetic field during operation. This field may under some circumstances interfere with active or passive medical implants. To reduce the risk of serious or fatal injury we recommend persons with medical implants to consult their physician and the medical implant manufacturer before operating this product.



WARNING: Read the warning instructions that follow before you use the product.

- Always be careful and use your common sense. Avoid all situations which you consider to be beyond your capability. If you feel uncertainty about the operating procedures after you read the operator's manual, consult an expert before you continue.
- Read and understand the operator's manual and the instructions on the product carefully before you start the product.
- Learn how to use the product and its controls safely and learn how to stop the product quickly.
- Learn to recognize the safety decals.
- Keep the product clean to make sure that you can clearly read signs and stickers.

- Clean fuel or oil spillage on the product before you operate the product and before you put the product in storage.
- Keep in mind that the operator will be held responsible for accidents that involve other persons or their property.
- Do not put hands or feet near parts that rotate.
- Do not put hands or feet below the product.
- Keep away from the discharge opening at all times.
- Always stop the blades when you operate the product on gravel surfaces.
- Do not operate the cutting deck if the grass catcher, discharge chute, or other safety devices are missing or defective.
- Always disengage the blades when you do not mow.
- Make sure that grass or other unwanted materials cannot touch hot exhaust or hot parts of the engine.
- Do not use the cutting deck to mow leaves or other unwanted materials that can cause buildup.
- Do not transport passengers. The product must only be used by one person.

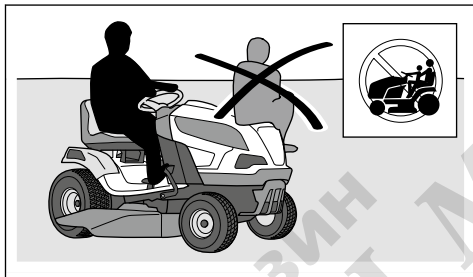

- Do not let the product stay unsupervised with the engine on. Always stop the blades, apply the parking brake, stop the engine and remove the ignition key before you let the product stay unsupervised.
- Only use the product in daylight or in other well-lit conditions. Keep the product at a safe distance from holes or other irregularities in the ground. Look out for other possible risks.
- Do not use the product in bad weather, for example in fog, in rain, moist or in wet locations, strong winds, intense cold, risk of lightning, etc.
- Find and mark stones and other fixed objects to prevent collision.
- Clear the area of objects such as stones, toys, wires, etc. that may become caught in the blades and be thrown out.

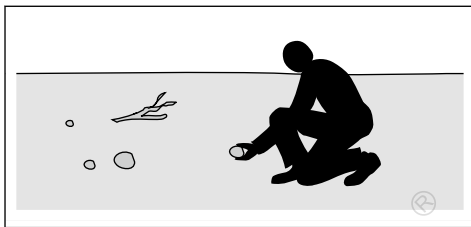

- Do not let children or other persons not approved for operation of the product to use or do servicing on it. Local laws may regulate the age of the user.
- Make sure that nobody else is in the vicinity of the product when you start the engine, engage the drive or start to move the product.
- Keep an eye on the traffic when you mow near a road or move across a road.
- Do not use the product if you are fatigued, while under the influence of alcohol or drugs, medicine or anything that can have a negative effect on your vision, alertness, coordination or judgement.
- Be careful when you put the product on a trailer or a truck and when you remove the product from a trailer or truck.
- Always park the product on a level surface with the engine stopped.
- Stop the engine and make sure that all parts have stopped before you clean or do maintenance on the product.
- Stop the engine and make sure that all parts have stopped before you remove the grass catcher or remove blockage in the discharge chute.
- Let the product become cool before you put it in storage.

Safety instructions regarding children



WARNING: Read the warning instructions that follow before you use the product.

- Serious accidents can occur if you are not on your guard for children in the vicinity of the product. Children can be attracted to the product and to mowing. It is very possible that children do not stay where you last saw them.
- Keep children away from the area to be mowed. Make sure that an adult is responsible for the children.
- Keep an eye out and stop the product if children enter the work area. Be very careful near corners, bushes, trees or other objects that prevents a clear view.
- Before and while you move the product in reverse, look behind you and look down to make sure there are no small children in the vicinity of the product.

- Do not let children ride along. They can fall off and get seriously injured or prevent safe maneuvering of the product.
- Do not let children operate the product.

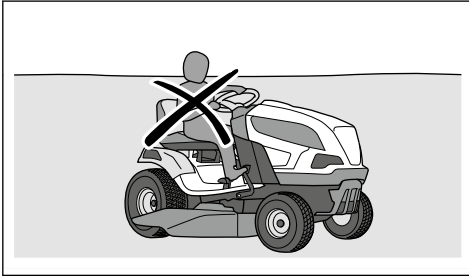

Safety instructions for operation



WARNING: Do not touch the engine or exhaust system during or directly after operation. The engine and the exhaust system become very hot during operation. Risk of burn injuries, fire and damage to property or adjacent areas. When you operate the product, keep away from bushes and other objects.



WARNING: Read the warning instructions that follow before you use the product.

- Always look down and behind you before and while you move in reverse. Look out for large and small obstacles.
- Decrease the speed before you turn around a corner.
- Stop the blades when you move across areas that you do not cut.



CAUTION: Read the caution instructions that follow before you use the product.

- Before you operate the product, clear the cold air intake of the engine from grass and dirt. If the cold air intake is blocked, there is a risk of engine damage.
- Move around stones and other larger objects carefully and make sure that the blades do not hit the objects.
- Do not operate the product across objects. Stop and examine the product and cutting deck if you operate the product across or into an object. If it is necessary, make repairs before you restart.
- Only use the cruise control for forward travel on smooth, straight surfaces (TC 220T model only).

Personal protective equipment



WARNING: Read the warning instructions that follow before you use the product.

- Use approved personal protective equipment when you use the product. Personal protective equipment cannot fully prevent injury but it decreases the degree of injury if an accident does occur. Let your dealer help you select the right equipment.
- Use approved hearing protection. Long-term exposure to noise can result in permanent hearing impairment.
- Use heavy-duty slip-resistant boots or shoes. Steel toes are recommended. Do not use open shoes or go with bare feet.

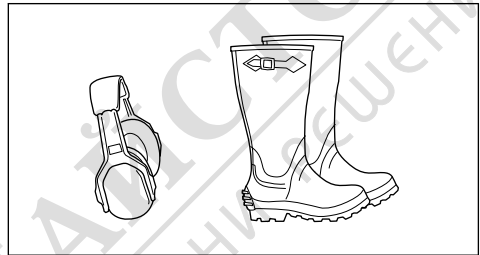

- Use protective gloves when necessary, for example when you attach, examine or clean the cutting equipment.
- Do not wear loose-fitting clothing, jewelry or other items that can get caught in moving parts.
- Keep first aid equipment and fire extinguisher near.

Safety devices on the product



WARNING: Read the warning instructions that follow before you use the product.

- Do not use a product with safety devices that are damaged or do not operate correctly. Do a check of the safety devices regularly. If the safety devices are damaged, speak to your Husqvarna service agent.
- Do not make modifications on safety devices. Do not use the product if protective plates, protective covers, safety switches or other protective devices are not attached or are damaged.

To do a check of the ignition lock

- Start and stop the engine to do a check of the ignition lock. Refer to *To start the product on page 16* and *To stop the product on page 19*.

- Make sure that the engine starts when you turn the ignition key to the start position.

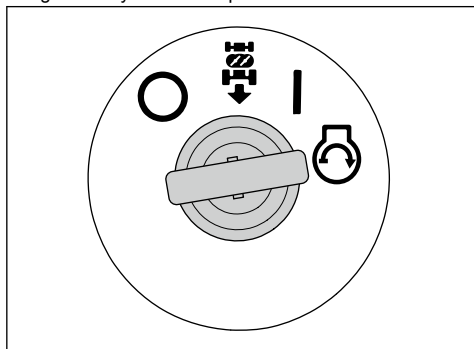

- Make sure that the engine stops immediately when you turn the ignition key to the stop position (O).

To do a check of the reverse operation system (ROS)

If the reverse operation system (ROS) does not operate correctly, speak to an approved service agent.

1. Start the product. Refer to *To start the product on page 16*.
2. Engage the cutting deck. Refer to *To engage and disengage the cutting deck on page 17*.
3. With the ignition key in the on position (A), push down on the rearward pedal. The engine must stop when you push down on the rearward pedal.

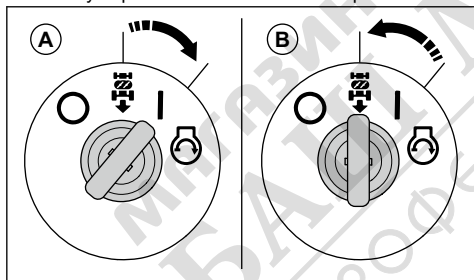

4. Start the product and engage the cutting deck again.
5. Turn the ignition switch to the ROS on position (B).
6. With the ignition key in the ROS on position, push down on the rearward pedal. The engine must not stop when you push down on the rearward pedal.

Operation conditions

These conditions are necessary to start the engine:

- The parking brake is applied.
- The drive of the blades is disengaged.
- The forward pedal and the rearward pedal are in their neutral position.

The engine must stop in these situations:

- The parking brake is not applied and the operator lifts from the seat.
- The cutting deck is engaged and the operator lifts from the seat.
- The cutting deck is engaged and the rearward pedal is pushed down but the ROS is disengaged.

The drive of the blades must stop in these situations:

- The operator lifts from the seat.
- The PTO button is pushed in.
- The grass catcher or other accessory is removed.

Try to start the engine without one of the conditions. Change the conditions and try again. Do this check daily.

To do a check of the forward pedal and rearward pedal

1. Start the product. Refer to *To start the product on page 16*.
2. Make sure that the forward pedal and rearward pedal are not blocked and can be operated freely.
3. Slowly push the forward pedal to move forward.
4. Release the forward pedal to brake. Make sure that the brake engages when the forward pedal is released.

Note: The product has an automatic brake that engages when you release the pedals.

5. Do the same procedure for the rearward pedal.
6. Make sure that the product does not move when the pedals are in their neutral position.

Parking brake



WARNING: If the parking brake does not work, the product can start to move and cause injury or damage. Make sure that the parking brake is regularly examined and adjusted.

Refer to *To do a check of the parking brake on page 24*.

Muffler

The muffler keeps the noise levels to a minimum and sends the exhaust fumes away from the operator.

Do not use the product if the muffler is missing or damaged. A damaged muffler increases the noise level and the risk of fire.



WARNING: The muffler becomes very hot during and after use and when the engine operates at idle speed. Be careful near flammable materials and/or fumes to prevent fire.

To do a check of the muffler

- Examine the muffler regularly to make sure that it is attached correctly and not damaged.

Protective covers

Missing or damaged protective covers increase the risk of injury on moving parts and hot surfaces. Do a check of the protective covers before you operate the product. Make sure that the protective covers are correctly attached and do not have cracks or other damages. Replace damaged covers.

To cut grass on slopes



WARNING: Read the warning instructions that follow before you use the product.

- To cut grass on slopes increases the risk that you can not control the product and that it overturns. This can cause injury or death. It is necessary to cut the grass carefully on all slopes. If you cannot reverse up a slope or if you do not feel safe, do not cut it.
- Remove stones, branches and other obstacles.
- Cut up and down the slope, not from side to side.
- Do not operate the product on ground that slopes more than 10°.

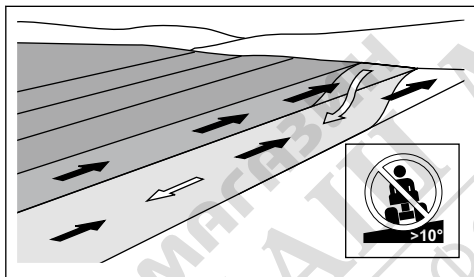

- Do not start or stop on a slope.
- Move smoothly and slowly on slopes.
- Do not make sudden changes in speed or direction.
- Do not turn more than necessary. Turn slowly and gradually when you move down a slope. Move at low speed. Turn the wheel carefully.
- Look out for and do not move across furrows, holes and bumps. There is a higher risk that the product overturns on ground that is not flat. Long grass can hide obstacles.
- Do not cut grass near edges, ditches or banks. The product can suddenly overturn if a wheel moves across the edge of a steep slope or a ditch, or if an edge gives way. If the product falls into water, there is a risk of drowning.

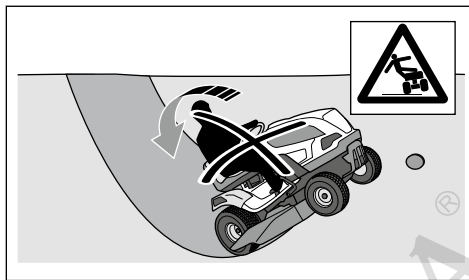

- Do not cut wet grass. It is slippery, and tires can lose their grip so that the product skids.
- Do not put your foot on the ground to try to make the product more stable.
- Move very carefully if an accessory or other object is attached that can make the product less stable.
- Follow the manufacturer's recommendations for wheel weights or counterweights.

Tow safety

- Only use tow equipment approved by Husqvarna.
- Use the tow bar to attach the equipment.
- Do not tow equipment that is heavier than the maximum permitted tow equipment weight. Refer to *Technical data on page 40*.

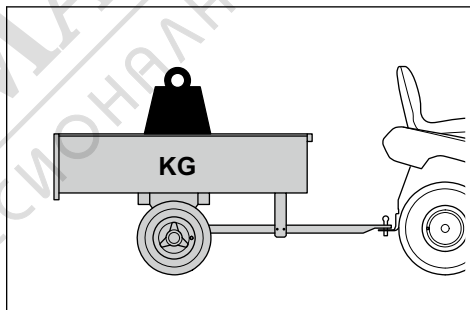

- Make sure that no other persons are near the product when you tow equipment.
- Be careful when you tow equipment on slopes or rough ground.
- Operate the product at low speed when you tow equipment.

Fuel safety



WARNING: Be careful with fuel. It is very flammable, and can cause injury and damage to property.



WARNING: Read the warning instructions that follow before you use the product.

- Do not fill the fuel tank indoors.
- Gasoline and gasoline fumes are poisonous and very flammable. Be careful with gasoline to prevent injury or fire.
- Do not remove the fuel tank cap or fill the fuel tank when the engine is on.
- Let the engine become cool before you refuel.
- Do not smoke when you fill fuel.
- Do not fill fuel near sparks or naked flames.
- If there are leaks in the fuel system, do not start the engine until the leaks are repaired.
- Do not fill above recommended fuel level. The heat from the engine and the sun makes the fuel expand and the fuel overflows if the tank is filled too much.
- Do not fill too much. If you spill fuel on the product, clean up the spill and wait until it is dry before you start the engine. If you spill on your clothing, change it.
- Store fuel in approved containers only.
- Store the product and fuel in such a way that there is no risk that fuel leaks or fumes can cause damage.
- Drain off the fuel in an approved container outdoors and away from naked flames.

Transport safety

- Use an approved transport vehicle for transportation of the product.
- The product is heavy and can cause crush injuries. Be careful when you load it onto or off a vehicle or trailer.
- A markets national or local regulations can set limit to the transportation of the product.
- The operator of the transport vehicle is responsible to attach the product safely during transport. Refer to *To safely attach the product for transportation on page 38*.

Battery safety



WARNING: A damaged battery can cause an explosion and cause injury. If the battery has a deformation or is damaged, speak to an approved Husqvarna service agent.



WARNING: Read the warning instructions that follow before you use the product.

- Use protective glasses when you are near batteries.
- Do not wear watches, jewelry or other metal objects near the battery.
- Keep the battery out of reach for children.
- Charge the battery in a space with good airflow.
- Keep flammable materials at a minimum clearance of 1 m when you charge the battery.

- Discard replaced batteries. See *Disposal on page 39*.
- Explosive gases can come from the battery. Do not smoke near the battery. Keep the battery away from open flames and sparks.

Safety instructions for maintenance



WARNING: The product is heavy and can cause injury or damage to property or the adjacent area. Do not do maintenance on the engine or the cutting deck without these conditions:

- The engine is off.
- The product is parked on a level surface.
- The parking brake is applied.
- The ignition key is removed.
- The cutting deck is disengaged.
- The ignition cables are removed from the plugs.



WARNING: The exhaust fumes from the engine contain carbon monoxide, an odourless, poisonous and very dangerous gas. Do not run the product in closed spaces or spaces with not sufficient air flow.



WARNING: Read the warning instructions that follow before you use the product.

- For best performance and safety, do maintenance on the product regularly as given in the maintenance schedule. Refer to *Maintenance schedule on page 20*.
- Electrical shocks can cause injuries. Do not touch the cables when the engine is on. Do not do a function test on the ignition system with your fingers.
- Do not start the engine if the protective covers are removed. There is a high risk of injury caused by moving or hot parts.
- Let the product become cool before you do maintenance near the engine.
- The blades are sharp and can cause cuts. Wind protection around the blades or use protective gloves when you do work on the blades.
- Do not park the product near the edge of a ditch or slope to get access to the cutting deck.



CAUTION: Read the caution instructions that follow before you use the product.

- Do not turn over the engine if the spark plug or ignition cable is removed.

- Make sure that all nuts and bolts are tightened correctly and that the equipment is in good condition.
- Do not change the adjustment of governors. If the engine speed is too high, the product components

can become damaged. Refer to *Technical data on page 40* for highest permitted engine speed.

- The product is approved only with the equipment supplied or recommended by the manufacturer.

Assembly

Introduction



WARNING: Read and understand the safety chapter before you assemble the product.

Assembly overview

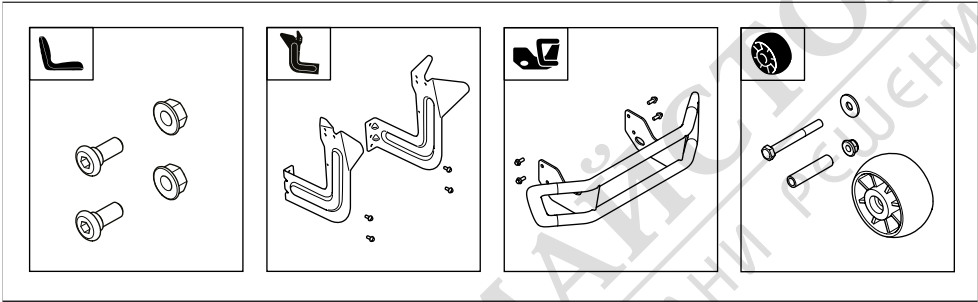

To install the seat

Refer to *Assembly overview on page 12* for the correct fasteners for this task.

1. Hold the seat in position and install the 2 screws (A) and the 2 nuts (B).

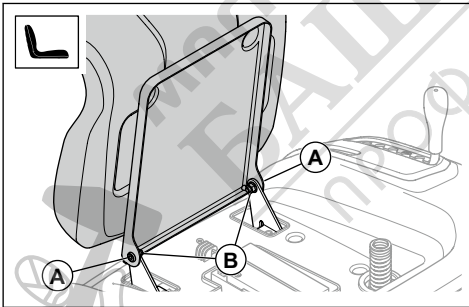

2. Do a check of the operator presence control. Refer to *Operation conditions on page 9*.



WARNING: Do not operate the product if the operator presence control is defective.

To install the anti-scalp wheels

Refer to *Assembly overview on page 12* for the correct fasteners for this task.

- Install the anti-scalp wheel (A), the bushing (B), the washer (C), the bolt (D), and the nut (E) in 1 of the 3 holes.

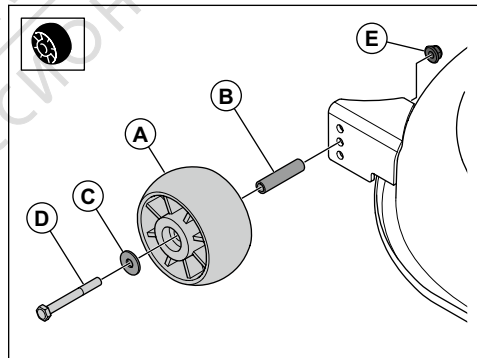

To install the front bumper TC 220T

Note: The front bumper is an accessory for TC 215T.

1. Remove the 4 screws on the left and right side of the muffler cover. Do not discard the screws.

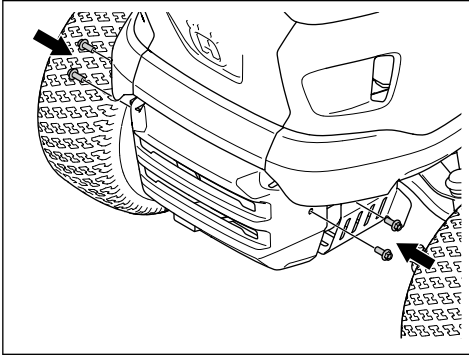

2. Install the front bumper and the 4 screws.

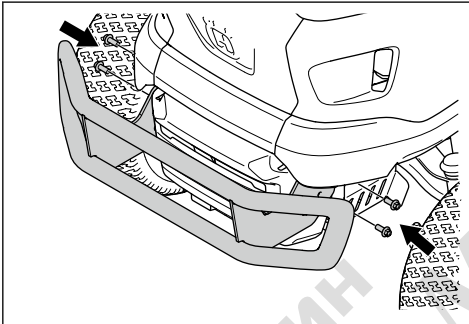

To install the brackets for the grass catcher

Refer to *Assembly overview on page 12* for the correct fasteners for this task.

1. Install the left bracket with the 2 bolts.

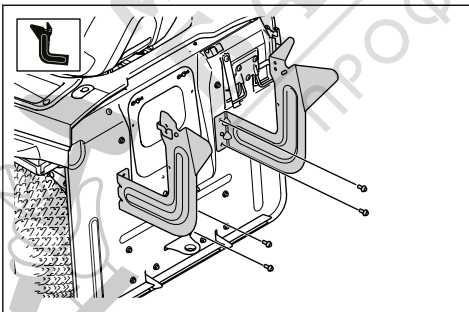

2. Install the right bracket with the 2 bolts.

3. Put the left part (A) of the rod assembly in the hole in the left bracket.

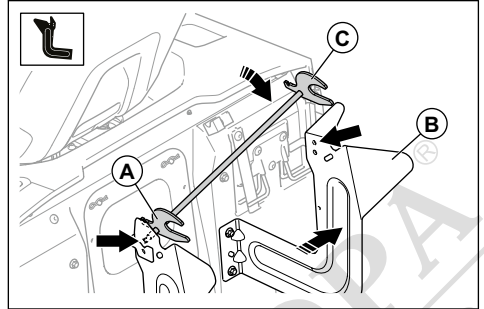

4. Carefully push the right bracket (B) to the right. Put the right side (C) of the rod assembly in the hole in the right bracket.



CAUTION: Do not push the brackets too much.

5. Install the 2 R-clips.

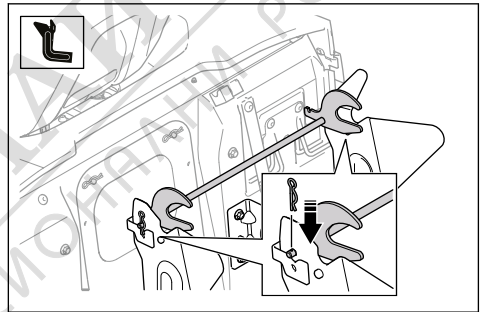

To assemble the grass catcher

1. Install the front frame (A) through the fabric loops (B) on each side of the grass catcher.

2. Install the front frame to the brackets on the top frame (C) with 2 screws (D) and 2 nuts (E) on each side.

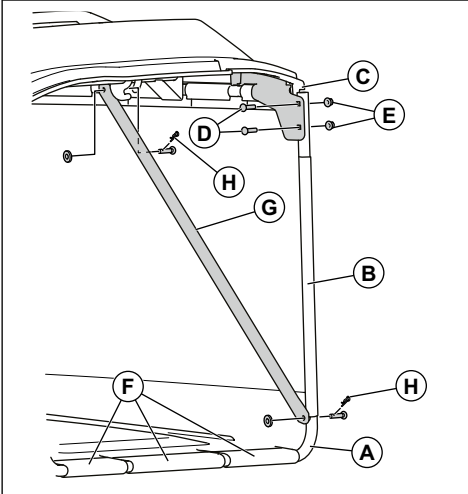

3. Attach the rubber tube elements (F) to the bottom of the front frame.
4. Install the 2 struts (G) to the front frame and the top frame with 2 clips (H) on each side.
5. Put the grass catcher handle down through the grass catcher cover and the holes in the grass catcher frame.

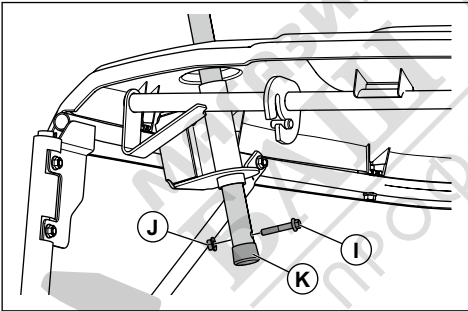

6. Install the screw (I) and the nut (J) in the tube of the grass catcher handle.
7. Install the end plug (K) to the tube of the grass catcher handle.

To install and remove the grass catcher

1. Tilt the grass catcher and put it on the 2 brackets.

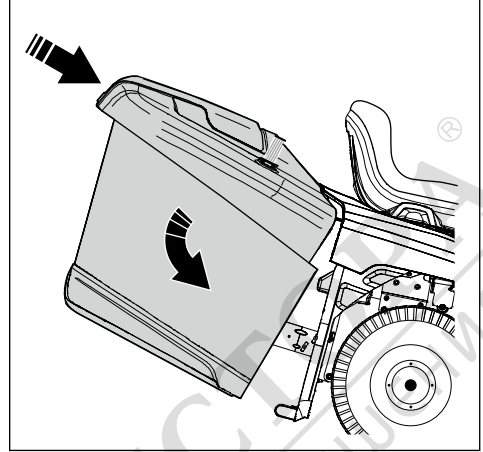

2. Make sure that the lock lever for the grass catcher is in the unlocked position.

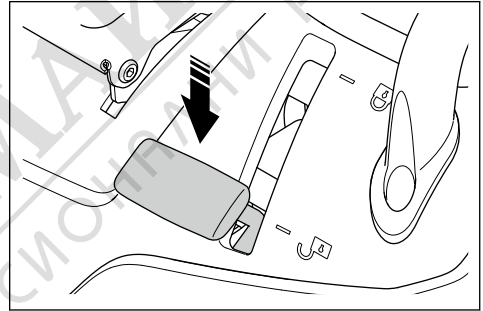

3. Release the grass catcher and let it move into position.
4. Move the lock lever for the grass catcher to the locked position. The grass catcher locks in position.

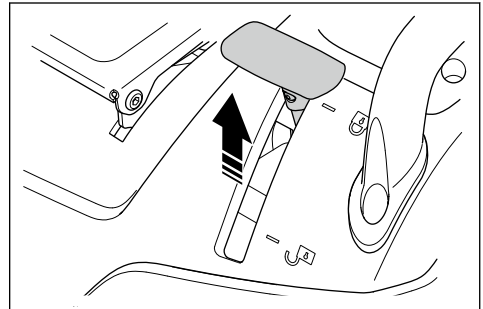

5. To remove the grass catcher, move the lock lever for the grass catcher to the unlocked position. Lift the grass catcher from the brackets.

To connect the battery



WARNING: Risk of electric shock. Make sure that the ignition switch is in the off position and that the ignition key is removed.

The location of the battery is above the left rear wheel.

1. Remove the left handle if it is installed. Refer to *To remove and install the handle (TC 220T)* on page 15.
2. Fold the seat forward.
3. Remove the 4 screws and the storage compartment.

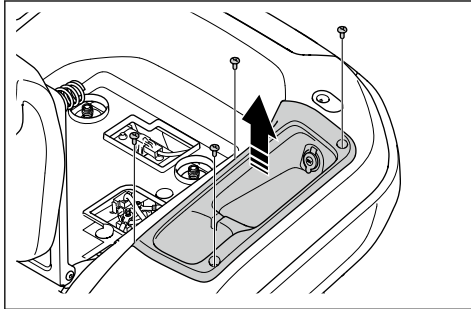

4. Make sure that the red battery cable is installed to the positive (+) terminal on the battery.
5. Remove the screw and the nut on the negative (-) terminal on the battery.
6. Attach the black battery cable to the negative (-) terminal on the battery and install the nut and the screw.

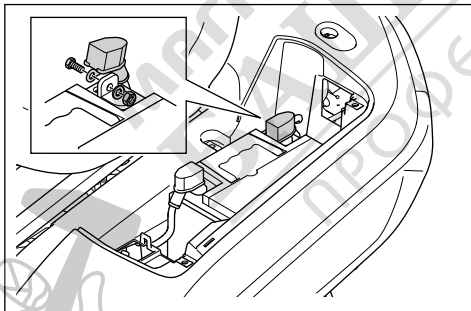

7. Attach the terminal cover.
8. Install the storage compartment and the 4 screws.
9. Install the left handle if it was removed. Refer to *To remove and install the handle (TC 220T)* on page 15.

To remove and install the handle (TC 220T)

Note: The handle is an accessory for the TC 215T model.

1. Remove the 2 screws and the handle.

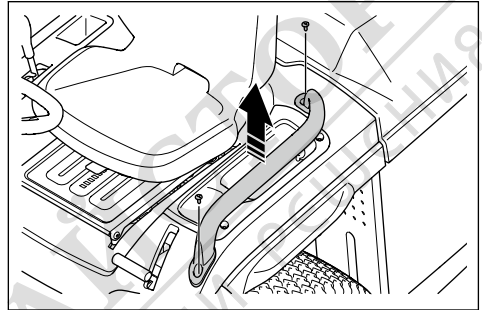

2. Install the handle in the opposite sequence.

Operation

Introduction



WARNING: Read and understand the safety chapter before you use the product.

To start to use Husqvarna Connect

1. Download the Husqvarna Connect app on your mobile device.
2. Register in the Husqvarna Connect app.
3. Do the instruction steps in the Husqvarna Connect app to connect and register the product.

To fill fuel



WARNING: Gasoline is very flammable. Be careful and refuel outdoors, refer to *Fuel safety on page 10*.



WARNING: Do not use the fuel tank as a support area.



CAUTION: Incorrect type of fuel can result in engine damage.

The engine runs on gasoline with a minimum octane rating of 91 RON (87 AKI), not mixed with oil. We recommend biodegradable alkylate gasoline. Do not use gasoline that contains more than 10% ethanol.

- Do a check of the fuel level before each use and refuel if it is necessary.
- Do not fully fill the fuel tank. Keep a space of a minimum 2.5 cm.

To adjust the seat



WARNING: Do not adjust the seat during operation of the product.

1. To adjust the seat forward and rearward, put your feet on the footrest plates.
2. Push the lever below the front edge of the seat up and move the seat to the correct position.

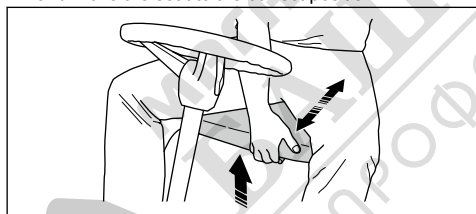

To do before you start the product



WARNING: Before you operate the product, carefully read and understand the safety instructions and the operation instructions.

1. Do a check of the engine oil level. Refer to *To do a check of the engine oil level on page 25*.
2. Fill the fuel tank with fuel. Refer to *To fill fuel on page 16*.

3. Make sure that the fuel shut-off valve is open. The fuel shut-off valve is open when the tab is in the direction of the fuel hose.

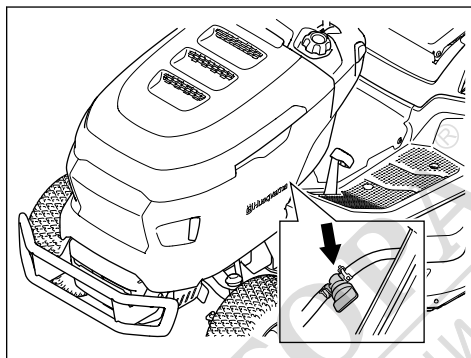

4. Make sure that the drive system is engaged. Refer to *To engage and disengage the drive system on page 17*.
5. Adjust the full bag sensor. Refer to *To adjust the full bag sensor on page 20*.
6. Put the cutting deck in the highest position. Refer to *To set the cutting height on page 18*.

To start the product

1. Make sure that the cutting deck is disengaged. Refer to *To engage and disengage the cutting deck on page 17*.
2. Sit in the seat in work position.
3. Apply the parking brake. Refer to *To apply and release the parking brake on page 17*.
4. Push the throttle control to the half throttle position (A).

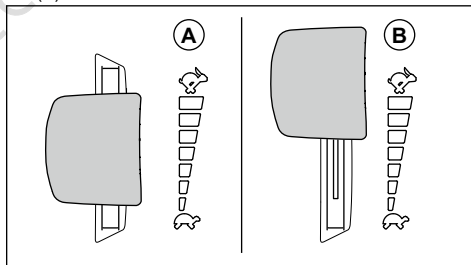

5. Turn the ignition key to the start position. When the engine starts, immediately release the ignition key. The ignition key goes back to the ON (I) position automatically when you release it.

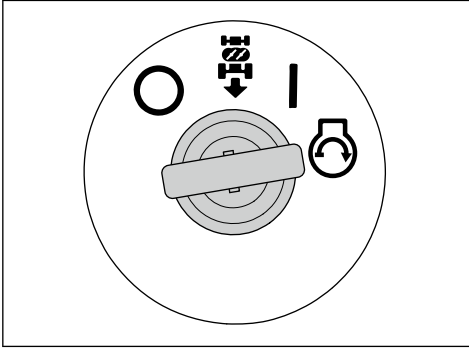

CAUTION: Do not operate the starter for more than 5 seconds at a time. If the engine does not start, wait 15 seconds before you try again.

6. Let the engine operate at half throttle for 3–5 minutes before you apply heavy load.
7. Push the throttle control to the full throttle position (B).

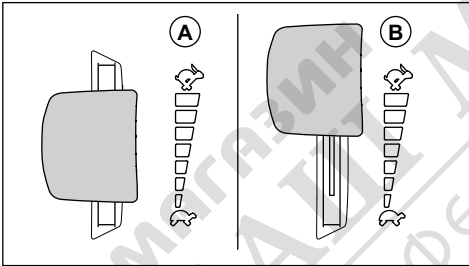

CAUTION: To engage the cutting deck when the engine is at full speed causes strain on the drive belts. Engage the cutting deck before you put the throttle control in the full throttle position.

To engage and disengage the drive system

To move the product with the engine off, the drive system must be disengaged.



CAUTION: Make sure that you fully pull out or push in the lever. Do not use middle positions.

The lever to engage or disengage the drive system is found behind the right rear wheel.

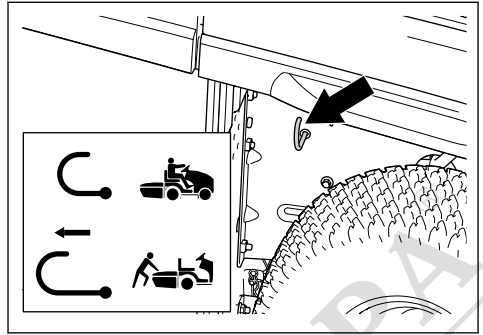

- Push the lever in fully to engage the drive system.
- Pull the lever out fully to disengage the drive system.

To apply and release the parking brake

- To apply the parking brake, do the steps that follow.
 - a) Push down the parking brake pedal (A) fully and pull up the parking brake lock (B).

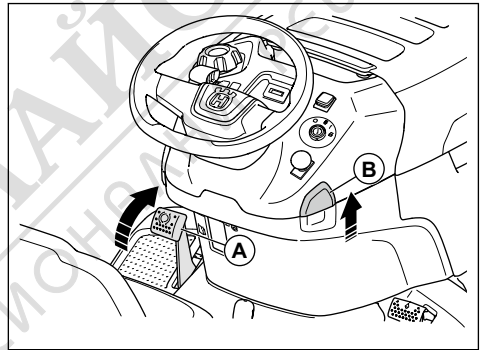

- b) Release the parking brake pedal.
- To release the parking brake, push down on the parking brake pedal and release it.

To engage and disengage the cutting deck



WARNING: Do not operate the cutting deck without a grass catcher or other accessory installed to the grass discharge.

- Pull out the PTO button to engage the cutting deck.

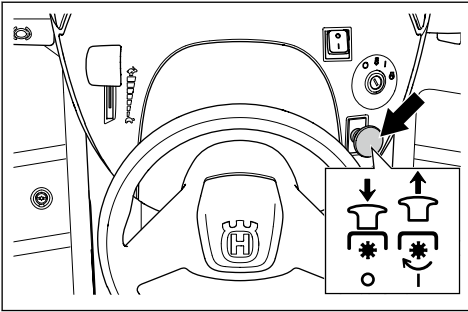

- Push in the PTO button to disengage the cutting deck.

To set the cutting height

- Pull the cutting height lever in the direction of the seat and put it in 1 of the notches to set the cutting height.

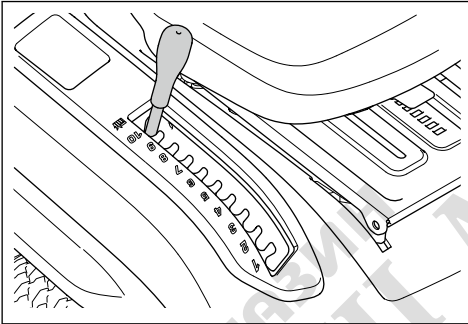

To operate the product

1. Start the engine. Refer to *To start the product on page 16*.
2. Release the parking brake. Refer to *To apply and release the parking brake on page 17*.



3. Carefully push the forward pedal (A) or the rearward pedal (B). The speed increases the more the pedal is pushed down.

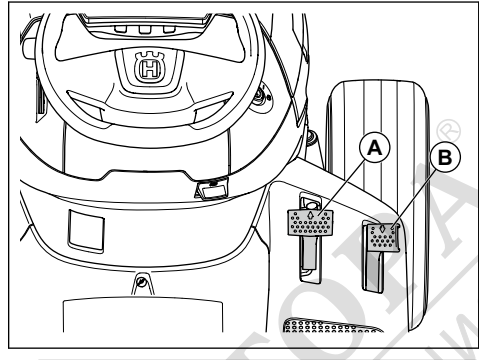

Note: The forward pedal and the rearward pedal go back to their neutral position when they are released.

4. Release the pedals to brake.
5. Select the correct cutting height. Refer to *To set the cutting height on page 18*.
6. Engage the cutting deck. Refer to *To engage and disengage the cutting deck on page 17*.

To use the cruise control (TC 220T)

Only use the cruise control for forward travel on smooth, straight surfaces.

1. Push the forward drive pedal (A) down. Keep the forward drive pedal in a position that gives the correct speed for the terrain.

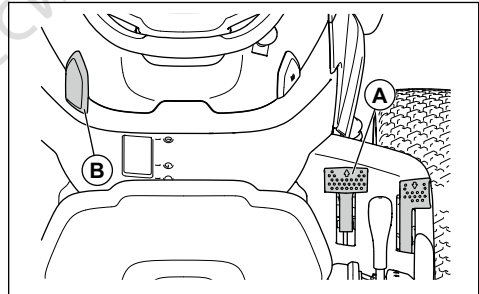

2. Pull the cruise control lock (B) up and hold it while you release the forward drive pedal.
3. Release the cruise control lock to engage the cruise control.
4. Push the forward drive pedal to disengage the cruise control.

To use the reverse operation system (ROS)

Note: If you try to go rearward with the product when the cutting deck is engaged, the engine stops immediately. Engage the ROS to go rearward with the product when the cutting deck is engaged.



WARNING: Before and while you operate the product rearward, look down and behind the product for the safety of others.

1. Turn the ignition key counterclockwise to the ROS position to engage the ROS.

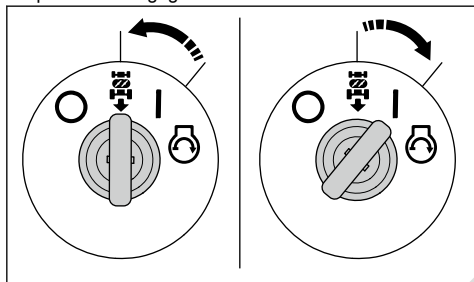

2. Slowly push down the rearward pedal to start movement.
3. Turn the ignition key clockwise to the engine ON (I) position to disengage the ROS.

To stop the product

1. Disengage the cutting deck. Refer to *To engage and disengage the cutting deck on page 17*.
2. Turn the ignition key to the OFF (O) position.

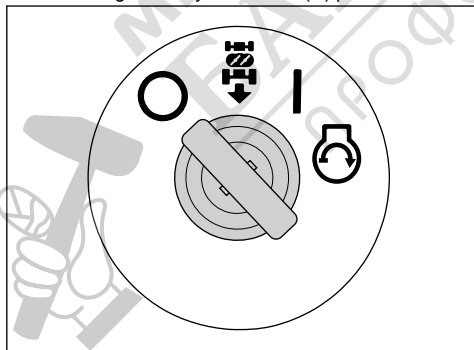

3. When the product is stationary and the engine is off, apply the parking brake. Refer to *To apply and release the parking brake on page 17*.

To get a good cutting result

- For best performance, do maintenance on the product regularly as given in the maintenance schedule. Refer to *Maintenance schedule on page 20*.
- Do not cut a wet lawn. Wet grass can give a bad cutting result.
- Do not use tire chains when you operate the product with a cutting deck.
- Make sure that the cutting deck is level. Refer to *To adjust the parallelism of the cutting deck on page 31*.
- If the grass is high, start with a high cutting height and decrease it gradually.
- Move the product forward at low speed if the grass is high and thick.
- Use full throttle when you cut the grass.
- Cut the grass in an irregular pattern.
- To get the best cutting result, cut the grass frequently.

To empty the grass catcher

The product has an alarm that gives a sound if the grass catcher is full. To stop the alarm, disengage the cutting deck. Refer to *To engage and disengage the cutting deck on page 17*.

1. Move the product to a location where you can empty the grass catcher.
2. Make sure that the pedals are in the neutral position and apply the parking brake.
3. Move the lock lever for the grass catcher to the unlocked position.

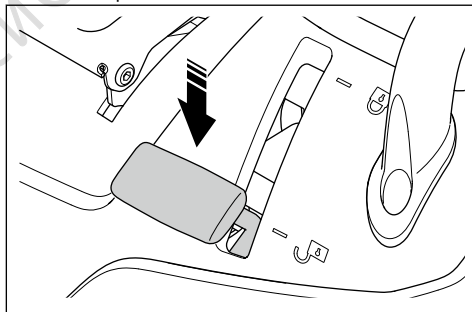

- Pull up the grass catcher handle to the highest position.

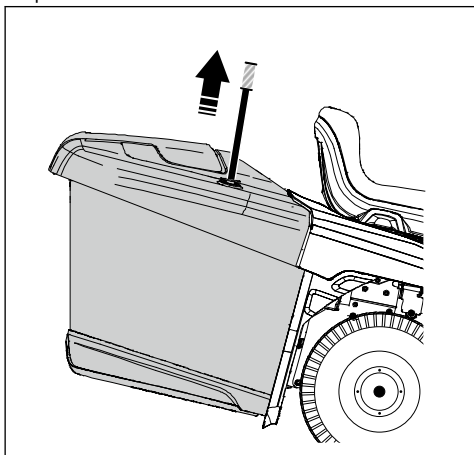

- Pull the grass catcher handle forward to tilt the grass catcher and empty the grass.

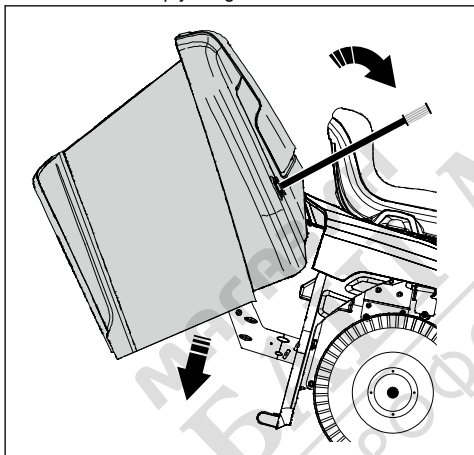

- Push the grass catcher handle rearward to lower the grass catcher. Make sure that the grass catcher is fully lowered.
- Move the lock lever for the grass catcher to the locked position. The grass catcher locks in position.

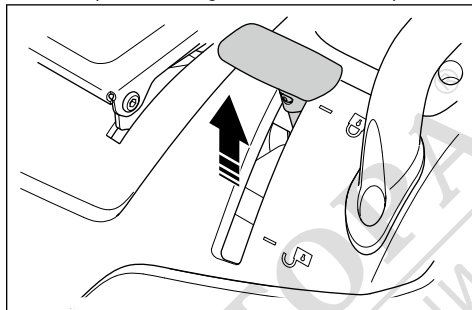

To adjust the full bag sensor

- Stop the engine and apply the parking brake.
- To adjust the full bag sensor, move the lever.

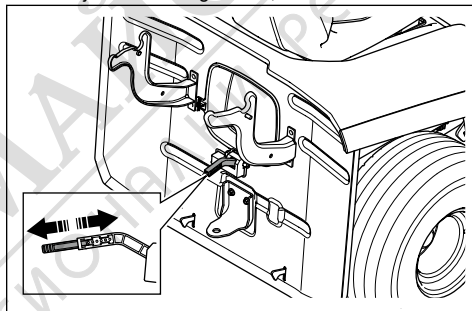

- If the grass is heavy, push the lever in.
- If the grass is dry, pull the lever out.

Maintenance

Introduction



WARNING: Before you do any maintenance work you must read and understand the safety chapter.

Maintenance schedule

X = The instructions are given in this operator's manual.

O = The instructions are not given in this operator's manual. Let an approved service agent do the maintenance.

Maintenance schedule		Before each use/ weekly	Every 50 h or annually
General	Clean the battery and the terminals.		O
	Do a check of the battery level. Charge the battery if it is necessary.		X
	Examine all belts and pulleys for wear and damage. Replace worn or damaged parts.		O
	Clean the engine and the transmission.	X	X
	Examine all wires for damage.		O
	Lubricate the product. Refer to the lubrication overview.		X
	Make sure that all fasteners are tightened correctly.		O
	Make sure that the tire pressure is correct in all tires.	X	X
Engine	Examine the fuel hose for wear and damage. Replace the fuel hose if it is necessary.		O
	Replace the fuel filter.		X
	Clean the air filter.	X	
	Replace the air filter.		X
	Examine the muffler and the heat deflector.	X	X
	Do a check of the engine oil level. Fill with engine oil if it is necessary.	X	
	Replace the engine oil.		X
	Replace the engine oil filter.		X
	Replace the spark plug.		X
	Do a check of the engine speed. Adjust the engine speed if it is necessary.		O
Transmission, controls and drive system	Examine the transmission cooling fan.	X	X
	Remove the wheels and lubricate the axles.		O
	Make sure that the product does not move when the pedals are in the neutral position.		X
	Do a check of the forward and rearward drive at different speeds.		O
	Do a check of the switch for the blade engagement control.		X
	Do a check of the switch for the cutting height lever.		X
	Do a check of the switches for the forward pedal and rearward pedal.		X
	Do a check of the parking brake.	X	
	Do a check of the operator presence control (OPC).	X	

Maintenance schedule		Before each use/ weekly	Every 50 h or an- nually
Cutting equipment	Clean the cutting deck, below the belt covers and below the cutting deck.		X
	Do a check of the parallelism of the cutting deck. Adjust the cutting deck if it is necessary.		X
	Examine the cutting deck belt for wear and damage.		O 
	Examine the blades for wear and damage. Sharpen or replace the blades if it is necessary.		X
	Do a check of the blade brakes (if equipped).		O
Grass catcher (TC models only)	Examine the grass catcher and the switches for the grass catcher.		X

Lubrication schedule

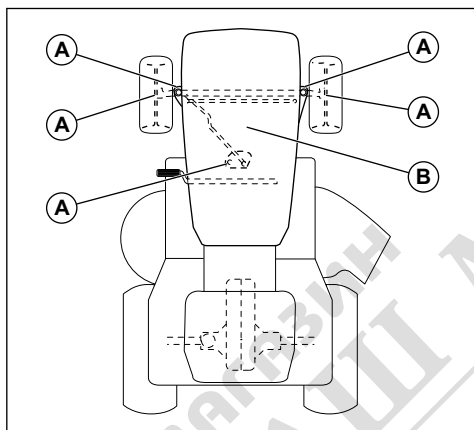

A. General lubrication. Lubricate the spindle grease connection and the gear teeth of the sector gear and the steering column.

B. Engine lubrication. Refer to *To do a check of the engine oil level on page 25*.

To clean the product



CAUTION: Do not use a high-pressure washer or a steam cleaner. Water can go into bearings and electrical connections and cause corrosion which causes damage to the product.

Clean the product immediately after use.

- Do not clean hot surfaces such as the engine, muffler and exhaust system. Wait until the surfaces are cool, then remove the grass or dirt.

- Before you clean with water, clean with a brush. Remove grass cuttings and dirt on and around the transmission, the transmission air intake, and the engine.
- Clean the top of cutting deck, below the belt covers and below the cutting deck. To clean the cutting deck, refer to *To clean the cutting deck on page 22*.
- Use running water from a hose to clean the product. Do not use high pressure.
- Do not point the water at electrical components or bearings. Detergent usually increases the damage.
- When the product is clean, start the cutting deck for a short period to blow off remaining water.

To clean the engine and the muffler

Keep the engine and muffler free from grass cuttings and dirt. Grass cuttings soaked in fuel or oil on the engine can increase the fire risk and the risk that the engine becomes too hot. Let the engine cool before it is cleaned. Clean with water and a brush.

Grass cuttings around the muffler dry quickly and are a fire risk. Use a brush or remove the grass cuttings with water when the muffler is cold.

To clean the cutting deck



WARNING: Do not use the product with a broken or missing deck washout port. There is a risk of thrown objects. Replace a broken or missing deck washout port immediately.

- Park the product in a clear area on your lawn that is near a water source with a garden hose.



CAUTION: Do not point the discharge chute of the product in the direction of buildings or vehicles.

2. Make sure that the cutting deck is disengaged. Refer to *To engage and disengage the cutting deck on page 17.*
3. Stop the engine. Refer to *To stop the product on page 19.*
4. Apply the parking brake. Refer to *To apply and release the parking brake on page 17.*
5. Connect a garden hose (A) to the deck washout port (B) and start the water supply.

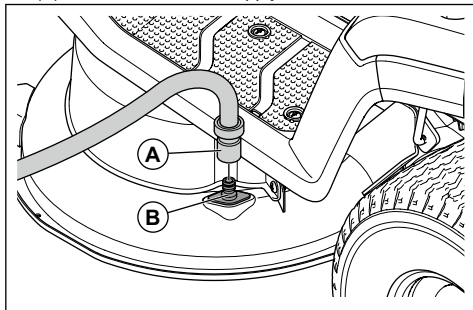

6. Sit in the seat and start the engine. Refer to *To start the product on page 16.*



CAUTION: Examine the area again to make sure that the area is clear before you start the engine.

7. Engage the cutting deck and let it operate at full throttle until the cutting deck is clean. Refer to *To engage and disengage the cutting deck on page 17.*
8. Disengage the cutting deck and stop the engine. Refer to *To engage and disengage the cutting deck on page 17* and *To stop the product on page 19.*
9. Stop the water supply and disconnect the garden hose from the deck washout port.
10. Move the product to a dry area.
11. Sit in the seat and start the engine. Refer to *To start the product on page 16.*
12. Engage the cutting deck and let it operate until the cutting deck is dry.

To clean the air intake of the engine



WARNING: Stop the engine. The air intake has rotating parts which can cause injury to your fingers.

Note: The illustration shows one type of engine. The engine in your product can be different, but the procedure is the same.

1. Open the engine cover.

2. Make sure that the air intake on the engine is not blocked.

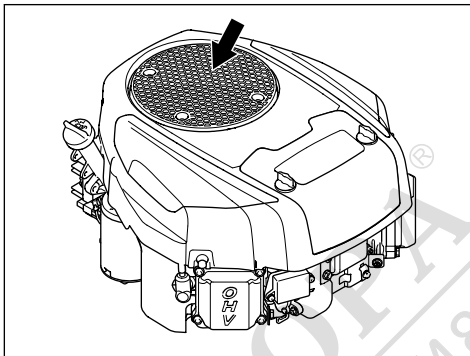

3. Remove grass and dirt with a brush.

To clean the cooling fan on the transmission



WARNING: Stop the engine. The cooling fan rotates and can cause injury to your fingers.

1. Remove the center chute. Refer to *To remove and install the center chute on page 30.*
2. Clean the cooling fan on the transmission with compressed air.

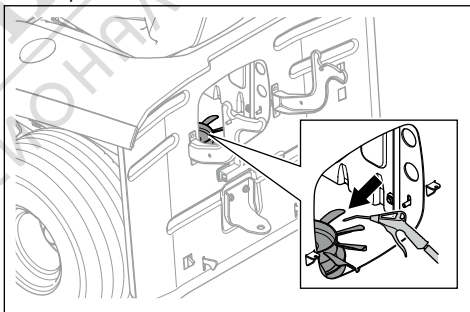

To remove and install the engine cover

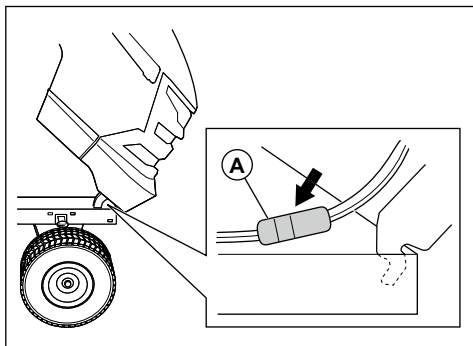

1. Open the engine cover.
2. Disconnect the headlight wire connector (A).
3. Tilt the engine cover forward and lift it to remove it from the product.
4. Install the engine cover in the opposite sequence.

To do a check of the parking brake

1. Park the product on a hard surface that slopes.

Note: Do not park the product on a grass slope when you do a check of the parking brake.

2. Apply the parking brake. Refer to *To apply and release the parking brake on page 17*.
3. If the product starts to move, let an approved service agent adjust the parking brake.
4. Push the parking brake pedal again to release the parking brake.

To replace the fuel filter

Note: The illustration shows one type of fuel filter. The fuel filter on your product can be different, but the procedure is the same.

1. Open the engine cover to get access to the fuel filter.
2. Close the fuel shut-off valve.
3. Compress the fuel tank hose to prevent leakage.
4. Move the hose clips away from the fuel filter with a pair of flat pliers.

5. Pull the fuel filter from the hose ends. A small quantity of fuel can leak.

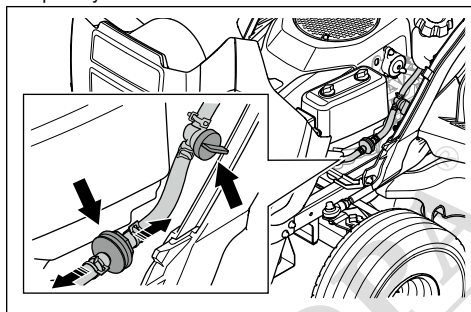

6. Push the new fuel filter into the hose ends. Apply liquid detergent to the ends of the fuel filter to make the connection easier.
7. Push the hose clips against the fuel filter.

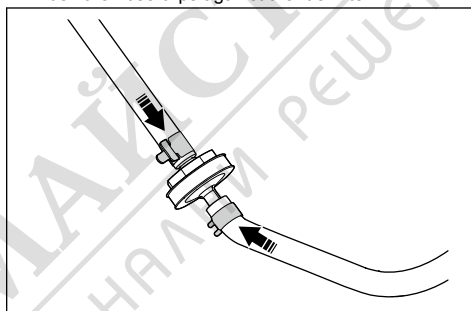

To clean and replace the air filter

Note: The illustration shows one type of air filter. The air filter on your product can be different, but the procedure is the same.

1. Turn the 2 knobs $\frac{1}{4}$ turn counterclockwise.
2. Remove the air filter cover.

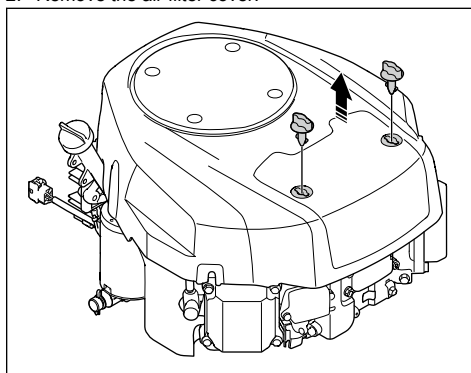

3. Carefully remove the air filter.

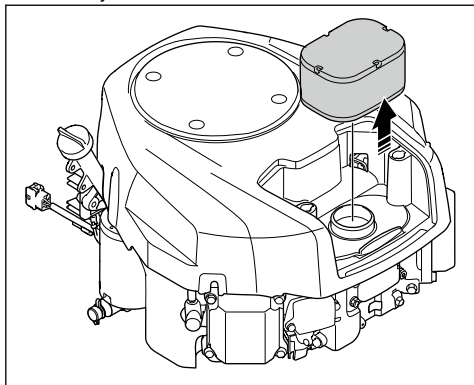

4. To clean a foam air filter, do the steps that follow.
- Remove the foam air filter from the air filter cartridge.
 - Clean the foam air filter with a weak detergent.
 - Let the foam air filter become dry.
 - Install the foam air filter around the air filter cartridge.
5. To clean a paper air filter, do the steps that follow.
- Hit the paper air filter against a hard surface.
 - Blow with compressed air from the inner side of the paper air filter.



CAUTION: If the paper air filter does not become clean, the paper air filter must be replaced.

6. Install the air filter in the opposite sequence.

To examine and replace a spark plug

- Open the engine cover.
- Remove the spark plug cap and clean around the spark plug.
- Remove the spark plug with a spark plug wrench.
- Examine the spark plug. Replace it if the electrodes are burned or if the insulation has cracks or damages. If the spark plug is not damaged, clean it with a steel brush.
- Measure the electrode gap and make sure that it is correct. Refer to *Technical data on page 40*.

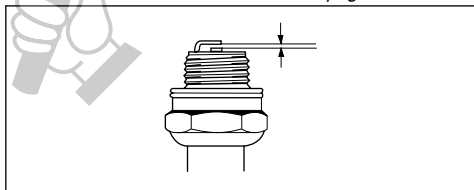

6. Bend the side electrode to adjust the electrode gap.

- Put the spark plug back in and turn it by hand until it touches the spark plug seat.
- Tighten the spark plug with the spark plug wrench until the washer is compressed.
- Tighten a used spark plug $\frac{1}{8}$ of a turn more, and a new spark plug $\frac{1}{4}$ turn more.



CAUTION: Spark plugs that are not tightened correctly can cause damage to the engine.

10. Attach the spark plug cap.



CAUTION: Do not try to start the engine if the spark plug or ignition cable is removed.

To do a check of the engine oil level

Note: The illustration shows one type of engine. The engine in your product can be different, but the procedure is the same.

- Park the product on level ground and stop the engine.
- Open the engine cover.
- Loosen the dipstick and pull it out.

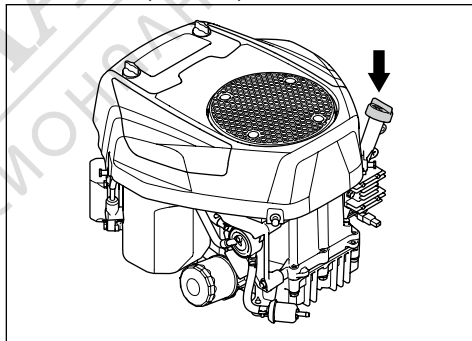

- Clean the oil from the dipstick.
- Put the dipstick back in and tighten it.
- Loosen and pull the dipstick out and read the oil level.

- The oil level must be between the marks on the dipstick. If the level is near the ADD mark, fill oil to the FULL mark.

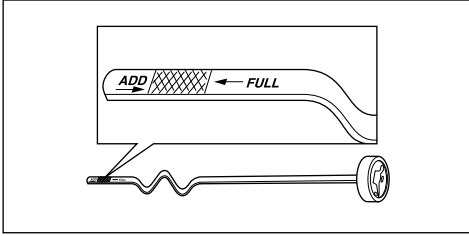

- Fill the oil through the hole that the dipstick sits in. Fill the oil slowly.

Note: Refer to *Technical data on page 40* for the types of engine oil that we recommend. Do not mix different types of oil.

- Tighten the dipstick.
- Start the engine and let it operate at idle speed for approximately 30 seconds.
- Stop the engine.
- Wait 30 seconds and do a check of the oil level again.

To replace the engine oil

If the engine is cold, start the engine and let it operate for 1–2 minutes before you drain the engine oil. This makes the engine oil warm and faster to drain.



WARNING: Do not operate the engine for more than 1–2 minutes before you drain the engine oil. The engine oil becomes very hot and can cause burn injuries. Let the engine become cool before you drain the engine oil.



WARNING: If you spill engine oil on your body, clean with soap and water.



- Remove the oil drain hose (A) from the holder (B) and put the oil drain hose through the gap (C).

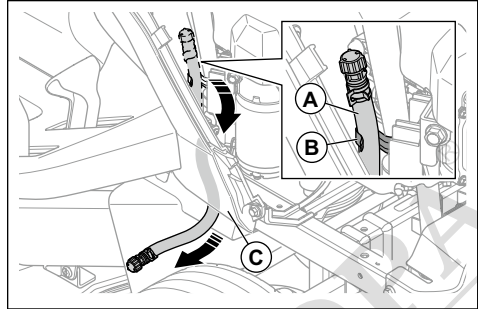

- Put a container below the oil drain plug.
- Remove the dipstick.
- Remove the end cap on the oil drain valve on the oil drain hose and let the engine oil drain into the container.

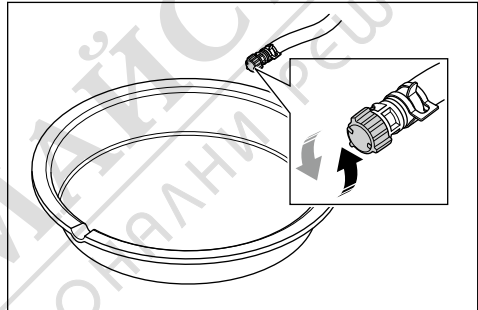

- When all oil is drained, install the end cap on the oil drain valve.
- If the engine has an oil filter, replace the oil filter. Refer to *To replace the oil filter on page 27*.
- Fill the oil slowly through the hole for the dipstick. Use an oil with viscosity that agrees with the temperature ranges in the figure. Refer to *Technical data on page 40*.

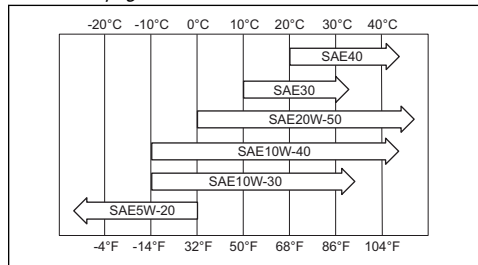

CAUTION: Do not mix different types of oil.

8. Install the dipstick.
9. Discard the used engine oil.

To replace the oil filter



WARNING: Use protective gloves. If you spill engine oil on your body, clean with soap and water.

Note: The illustration shows one type of oil filter. The oil filter can be different in your product, but the procedure is the same.

1. Drain the engine oil. Refer to *To replace the engine oil on page 26*.
2. Turn the oil filter counterclockwise to remove it.

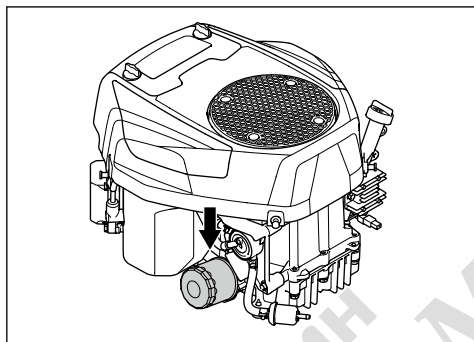

3. Lightly lubricate the rubber seal on the new oil filter with new engine oil.
4. Turn the oil filter clockwise by hand until the rubber seal is in position, then tighten a half turn more.
5. Fill the engine with new engine oil. Refer to *To do a check of the engine oil level on page 25*.
6. Start the engine and let it operate at idle speed for 3 minutes.
7. Stop the engine and make sure that there is no oil leakage from the oil filter.
8. Fill with engine oil to make up for the oil held in the new oil filter.

To replace the main fuse

The main fuse is found in the fuse holder on the start relay below the seat.

1. Fold the seat forward.
2. Remove the connector from the fuse holder.

3. Pull the main fuse from the fuse holder.

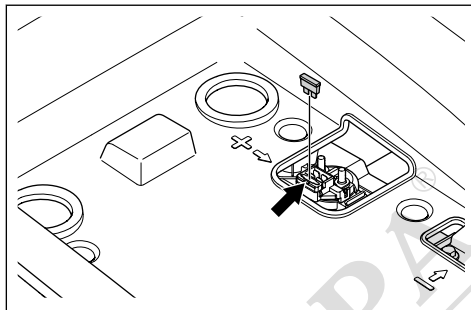

4. Replace the broken fuse with a new fuse of the same type. Refer to *Technical data on page 40*.

If the main fuse breaks again a short period after you replace it, there is a short circuit. Repair the short circuit before you operate the product again.

To charge the battery

Charge the battery if it is too weak to start the engine.

1. Connect the positive (+) charging cable to the positive (+) terminal (A) on the starter solenoid.

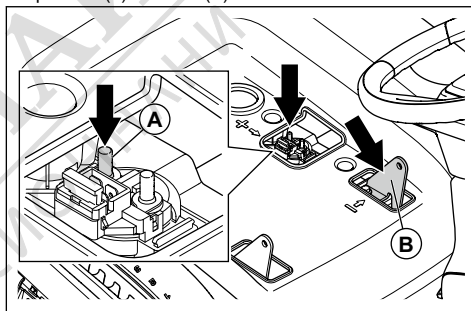

2. Connect the negative (-) charging cable to the negative (-) connection point (B).
3. Use a standard battery charger.



CAUTION: Do not use a boost charger or start booster. That will cause damage to the electrical system of the product.

4. Always disconnect the charger before starting the engine.

To do an emergency start of the engine

If the battery is too weak to start the engine, you can use jumper cables to do an emergency start. This product has a 12 V system with negative ground. The product that is used for the emergency start must also have a 12 V system with negative ground.

To connect the jumper cables



WARNING: Risk of explosion because of explosive gas that comes from the battery. Do not connect the negative terminal of the charged battery to or near the negative terminal of the weak battery.



CAUTION: Do not use the battery of your product to start other vehicles.

1. Connect one end of the red battery cable to the POSITIVE (+) terminal (A) on the start relay below the seat.

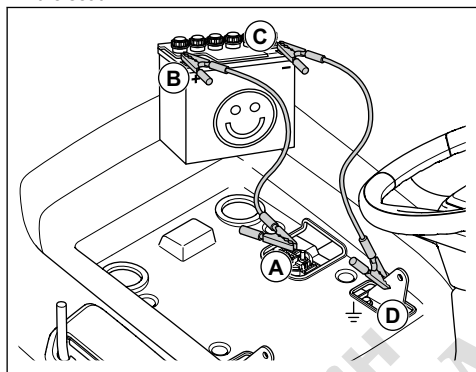

2. Connect the other end of the red battery cable to the POSITIVE (+) battery terminal (B) on the charged battery.



WARNING: Do not let the ends of the red battery cable touch the chassis. This will cause a short circuit.

3. Connect one end of the black battery cable to the NEGATIVE (-) battery terminal (C) on the charged battery.
4. Connect the other end of the black battery cable to a CHASSIS GROUND (D), away from the fuel tank and the battery.

To remove the jumper cables

Note: Remove the jumper cables in the opposite sequence to how you connect them.

1. Remove the BLACK cable from the chassis.
2. Remove the BLACK cable from the fully charged battery.
3. Remove the RED cable from the 2 batteries.

To replace the battery



WARNING: Risk of electrical shock and burn injuries. Do not use metal wristbands or other metal accessories. Metal items that touch the battery terminals can cause burn injuries, electrical shock, and short circuit of the battery.

1. Remove the left handle if it is installed. Refer to *To remove and install the handle (TC 220T)* on page 15.
2. Fold the seat forward.
3. Remove the 4 screws and the storage compartment.

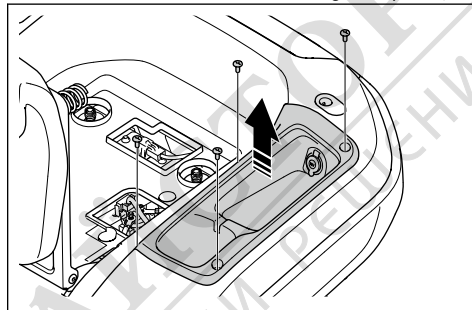

4. Remove the terminal cover on the black battery cable.
5. Remove the screw, the washer, the nut, and the black battery cable from the negative (-) terminal on the battery.

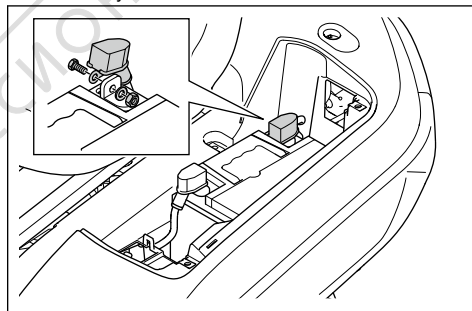

6. Remove the terminal cover on the red battery cable.
7. Remove the screw, the nut, and the red battery cable from the positive (+) terminal on the battery.
8. Carefully remove the battery from the product.
9. Put a new battery in position.
10. Attach the red battery cable to the positive (+) terminal on the battery and install the nut and the screw.
11. Install the terminal cover on the red battery cable.

12. Attach the black battery cable to the negative (-) terminal on the battery and install the nut, the screw and the terminal cover.
13. Install the battery cover and the attach the strap.
14. Install the storage compartment and the 4 screws.

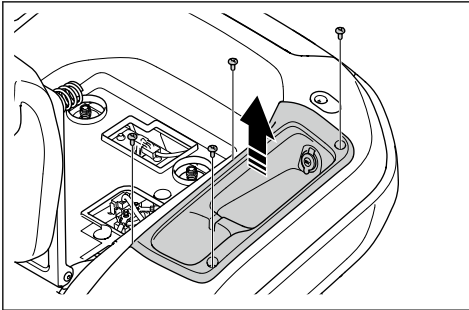

15. Install the left handle if it was removed. Refer to *To remove and install the handle (TC 220T) on page 15.*

Tire pressure

Make sure that the tire pressure is correct in all 4 tires. Refer to *Technical data on page 40.*

Cutting deck

To remove and install the cutting deck

1. Disengage the cutting deck and stop the engine.
2. Put the cutting deck in the lowest position.
3. Remove the 3 screws and the left belt cover.

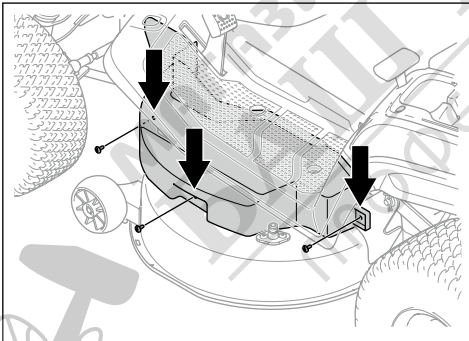

4. Remove the 3 screws and the right belt cover.

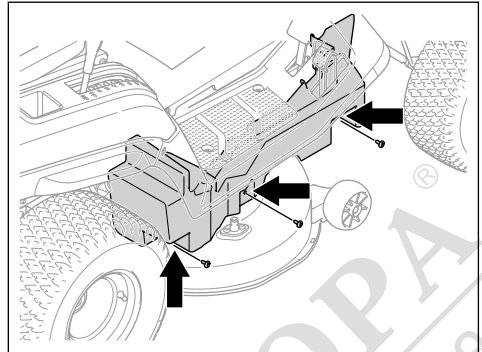

5. Remove the spring (A) from the spring holder (B) to decrease the tension of the cutting deck belt.

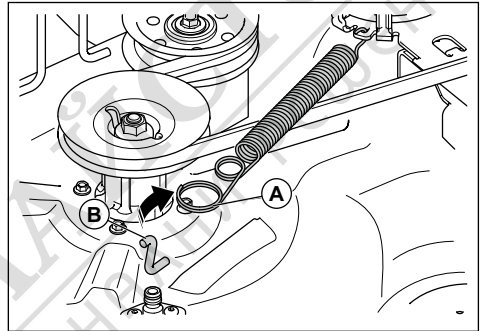

Note: The TC 220T model has 2 cutting deck belts and 2 springs.

6. Remove the cutting deck belt from the engine pulley.
7. Do the steps that follow to disconnect the front link.
 - a) Remove the clip (C) and the washer (D).

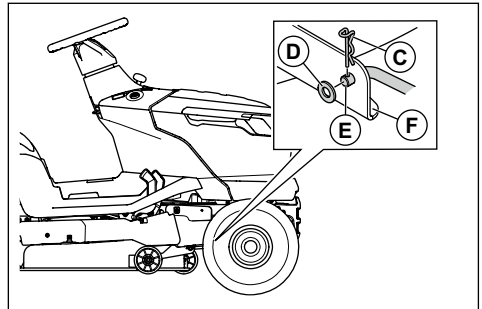

- b) Disconnect the front link (E) from the bracket (F) on the cutting deck.

- c) Put the front link in the front link holder.

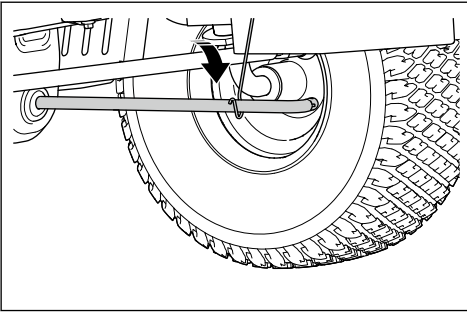

8. Do the steps that follow to disconnect the 2 rear links. There is one rear link on the left side and one rear link on the right side of the product.



WARNING: The cutting deck is heavy. Use a crowbar or equivalent below the cutting deck to hold the weight of the cutting deck when you disconnect the 2 rear links.

- a) Remove the clip (E) and the washer (F) from the front end of the left rear link.

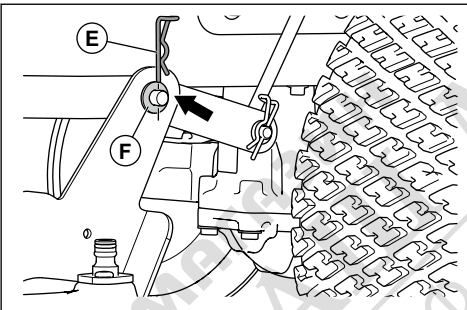

- b) Disconnect the cutting deck from the left rear link.
c) Pull and hold the cutting height lever in the lowest position with one hand. Remove the clip and the washer from the front of the right rear link.



WARNING: Do not release the cutting height lever. The mechanism for the cutting height adjustment is spring-loaded. The force from the spring can cause crush injury if you do not pull and hold the cutting height lever.

- d) Disconnect the cutting deck from the right rear link.
e) Carefully release the cutting height lever.



WARNING: The mechanism for the cutting height adjustment is spring-loaded. The force from the spring can cause crush injury. Keep body parts away.

9. Move the cutting height lever to the highest position.
10. Push down the lower chute and remove the cutting deck from the product.

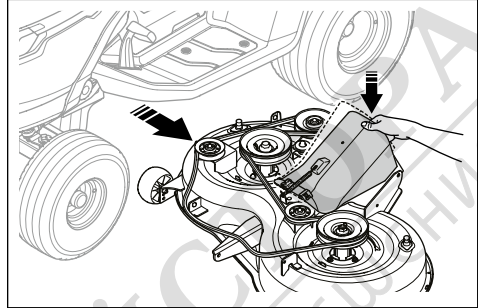

11. Install the cutting deck in the opposite sequence.



CAUTION: Make sure that the drive belt is installed correctly and does not get compressed when you install the cutting deck.

- a) Make sure that the lower chute is in the correct position when you install the cutting deck.

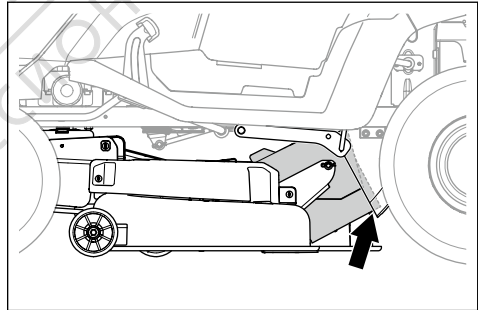

To remove and install the center chute

1. Disengage the cutting deck and stop the engine.
2. Remove the grass catcher.

- Remove the 2 clips.

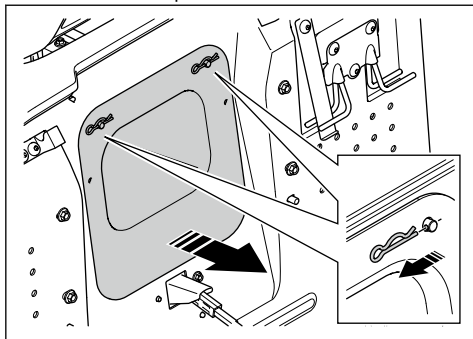

- Pull out the center chute.
- Install the center chute in the opposite sequence.

To adjust the parallelism of the cutting deck

To do a side-to-side adjustment of the cutting deck

If the cutting height is different between the right and left side, the cutting height can be adjusted.

- Make sure that the tire pressure is correct in all 4 tires. Refer to *Tire pressure on page 29*.
- Park the product on a level surface.
- Put the cutting deck in the highest position.
- Measure the distance (X) from the bottom edge of the cutting deck to the ground on the left and right side. The distance must be the same on the 2 sides.

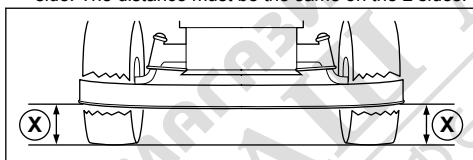

WARNING: The blades on the cutting deck are sharp and can cause injury. Use protective gloves.

- Loosen the locknuts on the cutting height stays.

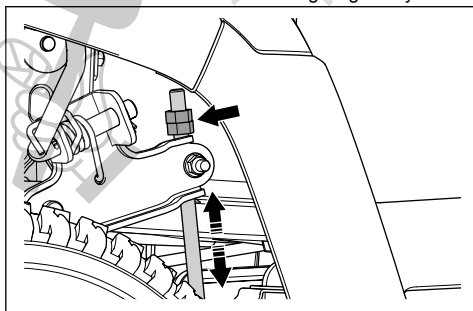

Note: The cutting height stays are behind the cutting deck, in front of the rear wheels.

- Adjust the nuts on the cutting height stays until the cutting deck has the same cutting height on the left and right side.
 - Turn the nuts counterclockwise to lower the cutting deck.
 - Turn the nuts clockwise to lift the cutting deck.
- Measure the distance again. Adjust until the 2 sides are equal.
- Tighten the locknuts when the side-to-side adjustment is complete.
- Cut some grass and examine the results. Adjust if it is necessary.

To do a front-to-rear adjustment of the cutting deck

The cutting deck must be level side to side before you do front to rear adjustment. Refer to *To do a side-to-side adjustment of the cutting deck on page 31*.

- Make sure that the tire pressure is correct in all 4 tires. Refer to *Tire pressure on page 29*.
- Park the product on a level surface.
- Put the cutting deck in the highest position.
- Measure the distance from the bottom edge of the cutting deck to the ground at the rear (A) and at the front (B). The distance at the front must be 5–10 mm lower than at the rear.

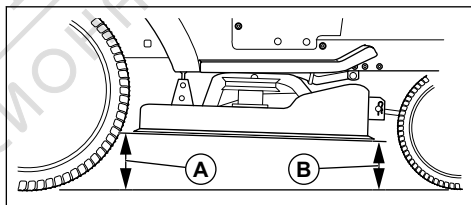

WARNING: The blades on the cutting deck are sharp and can cause injury. Use protective gloves.

- If it is necessary to make a front adjustment, loosen the locknut and turn the nut on the front link.

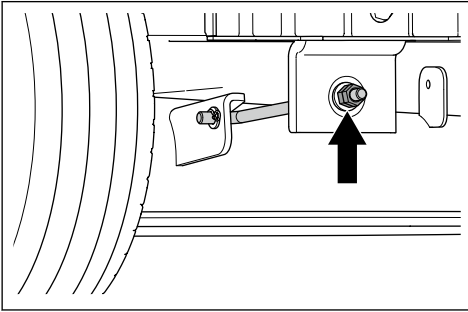

Note: The front link is in the front of the product, behind the muffler.

- Turn the nut counterclockwise to lower the front of the cutting deck.
- Turn the nut clockwise to lift the cutting deck.
- Tighten the locknut when the front adjustment is complete.

To examine the blades



CAUTION: Damaged or incorrectly balanced blades can cause damage to the product. Replace damaged blades. Let an approved service agent help you sharpen and balance blunt blades.

- Remove the cutting deck. Refer to *To remove and install the cutting deck on page 29*.
- Look at the blades to see if they are damaged and if it is necessary to sharpen them.

To replace the blades

- Remove the cutting deck. Refer to *To remove and install the cutting deck on page 29*.
- Lock the blades with a wooden block.

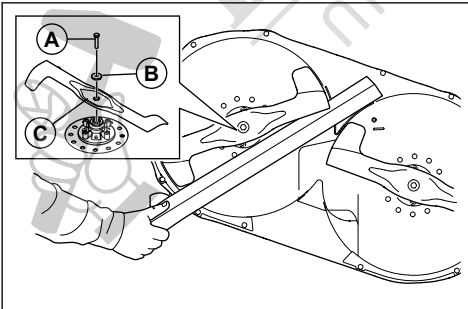

- Remove the bolt (A), the washer (B), and the blade (C).

- Install a new left blade on the left side and a new right blade on the right side. The left blade is identified with "Left" and the right blade is identified with "Right".

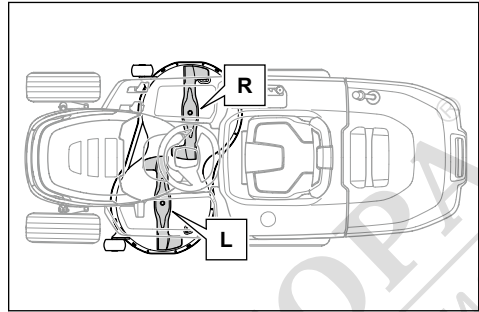

CAUTION: The blades have different direction of rotation. The right blade must be installed on the right side and the left blade must be installed on the left side.



WARNING: Incorrect blade type can cause objects to eject from the cutting deck and cause serious injury. Use only the blades given in *Technical data on page 40*.

- Make sure that the bent ends on the blades point in the direction of the cutting deck.
- Torque the bolts to 58.5–69.5 Nm.
- Install the cutting deck. Refer to *To remove and install the cutting deck on page 29*.

To replace the cutting deck belt (TC 215T)

- Remove the cutting deck. Refer to *To remove and install the cutting deck on page 29*.
- Remove the dirt and grass around the bearing housings, blade pulleys and from the top surface of the cutting deck.

3. Remove the nut (A), the washer (B), the bolt (C), and the idler pulley (D).

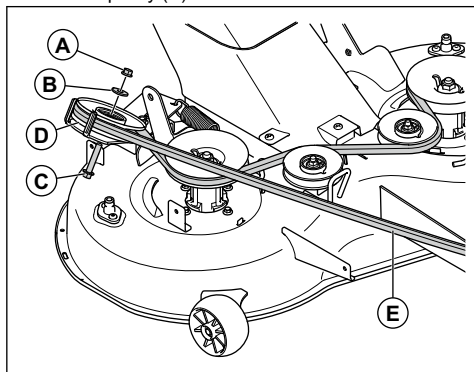

4. Remove the cutting deck belt (E) from the blade pulleys on the cutting deck.

5. Install a new cutting deck belt in the opposite sequence.

- a) Make sure that the cutting deck belt is in the correct position in all belt pulleys.

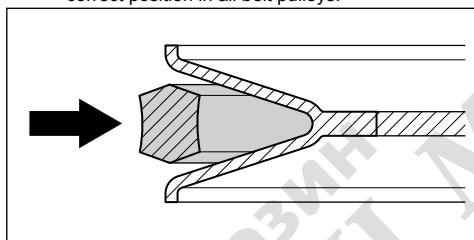

CAUTION: Make sure that the cutting deck belt is not twisted. Refer to the belt routing decal on the cutting deck.

To replace the cutting deck belt (TC 220T)

1. Remove the cutting deck. Refer to *To remove and install the cutting deck on page 29*.
2. Remove the dirt and grass around the bearing housings, blade pulleys and from the top surface of the cutting deck.

3. Remove the nut (A), the washer (B), the bolt (C), and the right idler pulley (D).

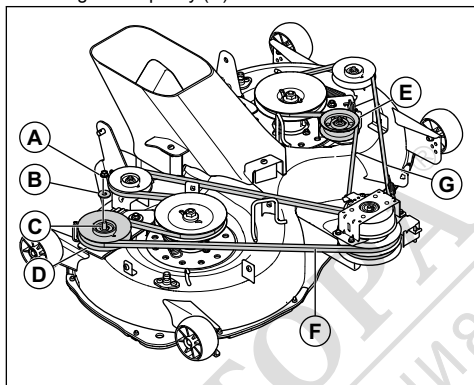

4. Remove the nut, the washer, the bolt, and the left idler pulley (E).

5. Remove the right cutting deck belt (F) and the left cutting deck belt (G) from the blade pulleys on the cutting deck.

6. Install new cutting deck belts in the opposite sequence.

- a) Make sure that the cutting deck belts are in the correct position in all belt pulleys.

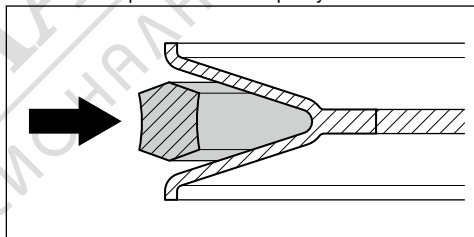

CAUTION: Make sure that the cutting deck belts are not twisted. Refer to the belt routing decal on the cutting deck.

To adjust the anti-scalp wheels

The anti-scalp wheels keep the cutting deck in the correct position on the ground and prevent lawn scalping in most terrain conditions. The anti-scalp wheels are adjusted correctly when they are slightly off the ground when the cutting deck is at the necessary cutting height.

1. Park the product on a level surface and stop the engine.
2. Put the cutting deck in the necessary cutting height. Refer to *To set the cutting height on page 18*.

- Remove the nut (A), the bolt (B), the washer (C), the anti-scalp wheel (D), and the bushing (E).

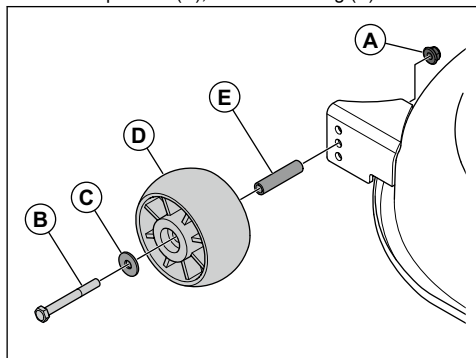

- Install the anti-scalp wheel, the bushing, the bolt, the washer, and the nut in 1 of the 3 holes.
- Adjust all anti-scalp wheels in the same procedure.

Troubleshooting

Troubleshooting schedule

If you cannot find a solution to your problems in this operator's manual, speak to your Husqvarna servicing dealer.

Problem	Cause	Action
The starter motor does not crank the engine.	The parking brake is not applied.	Apply the parking brake. Refer to <i>To apply and release the parking brake on page 17.</i>
	The cutting deck is engaged.	Disengage the cutting deck. Refer to <i>To engage and disengage the cutting deck on page 17.</i>
	The main fuse is blown.	Replace the main fuse. Refer to <i>To replace the main fuse on page 27.</i>
	The ignition lock is broken.	Speak to your Husqvarna servicing dealer.
	The connection between the cable and the battery is bad.	Make sure that the battery is connected correctly. Refer to <i>To connect the battery on page 15.</i>
	The battery is too weak.	Charge the battery. Refer to <i>To charge the battery on page 27.</i>
	The starter motor is damaged.	Speak to your Husqvarna servicing dealer.

Problem	Cause	Action
The engine does not start when the starter motor cranks the engine.	There is no fuel in the fuel tank.	Fill the fuel tank with fuel. Refer to <i>To fill fuel on page 16</i> .
	The spark plug is damaged.	Examine the spark plugs. Replace the spark plugs if it is necessary. Refer to <i>To examine and replace a spark plug on page 25</i> .
	The ignition cable is damaged.	Speak to your Husqvarna servicing dealer.
	There is dirt in the carburetor or fuel line.	Speak to your Husqvarna servicing dealer.
	The fuel filter is clogged.	Replace the fuel filter. Refer to <i>To replace the fuel filter on page 24</i> .
The engine does not run smoothly.	The spark plug is damaged.	Examine the spark plugs. Replace the spark plugs if it is necessary. Refer to <i>To examine and replace a spark plug on page 25</i> .
	The carburetor is incorrectly set.	Speak to your Husqvarna servicing dealer.
	The air filter is clogged.	Clean or replace the air filter. Refer to <i>To clean and replace the air filter on page 24</i> .
	The fuel tank vent is blocked.	Speak to your Husqvarna servicing dealer.
	There is dirt in the carburetor or fuel line.	Speak to your Husqvarna servicing dealer.
	The fuel filter is clogged.	Replace the fuel filter. Refer to <i>To replace the fuel filter on page 24</i> .
The engine has no power.	The air filter is clogged.	Clean or replace the air filter. Refer to <i>To clean and replace the air filter on page 24</i> .
	The spark plug is damaged.	Examine the spark plugs. Replace the spark plugs if it is necessary. Refer to <i>To examine and replace a spark plug on page 25</i> .
	There is dirt in the carburetor or fuel line.	Speak to your Husqvarna servicing dealer.
	The throttle cable is incorrectly adjusted.	Speak to your Husqvarna servicing dealer.
The engine stops when you try to operate the product rearward.	The reverse operation system (ROS) is not engaged.	Engage the reverse operation system (ROS). Refer to <i>To use the reverse operation system (ROS) on page 19</i> .

Problem	Cause	Action
The transmission does not have sufficient power.	The transmission air intake or the cooling fins are blocked.	Speak to your Husqvarna servicing dealer.
	The fan on the transmission is damaged.	Speak to your Husqvarna servicing dealer.
	There is no oil in the transmission or the oil level is too low.	Speak to your Husqvarna servicing dealer.
	The drive system is disengaged.	Engage the drive system. Refer to <i>To engage and disengage the drive system on page 17.</i>
The battery does not charge.	The battery is damaged.	Replace the battery. Refer to <i>To replace the battery on page 28.</i>
	The connection at the battery terminals is bad.	Make sure that the battery is connected correctly. Refer to <i>To connect the battery on page 15.</i>
There is vibration in the product.	The blades are loose.	Tighten the blades. Refer to <i>To replace the blades on page 32.</i>
	The blades are incorrectly installed.	Make sure that the blades are installed correctly. Refer to <i>To replace the blades on page 32.</i>
	The blades are not balanced.	Examine the blades for wear and damage. Refer to <i>To examine the blades on page 32.</i>
	The engine is loose.	Speak to your Husqvarna servicing dealer.
	The belt pulleys are skew or loose.	Speak to your Husqvarna servicing dealer.



Problem	Cause	Action
The cutting result is unsatisfactory.	The blades are blunt.	Examine the blades for wear and damage. Refer to <i>To examine the blades on page 32</i> .
	The blades are incorrectly installed.	Make sure that the blades are installed correctly. Refer to <i>To replace the blades on page 32</i> .
	The grass is long or wet.	Refer to <i>To get a good cutting result on page 19</i> .
	The cutting deck is not parallel.	Adjust the parallelism of the cutting deck. Refer to <i>To adjust the parallelism of the cutting deck on page 31</i> .
	There is grass blockage in the cutting deck.	Clean the cutting deck. Refer to <i>To clean the product on page 22</i> .
	There is grass blockage in the center chute.	Remove the grass blockage in the center chute.
	The air holes in the cutting deck are clogged.	Clean the cutting deck. Refer to <i>To clean the product on page 22</i> .
	There is dirt around the blade pulleys.	Clean the cutting deck. Refer to <i>To clean the product on page 22</i> .
	The tire pressure is different on the right and left sides.	Make sure that the tire pressure is correct in all 4 tires. Refer to <i>Tire pressure on page 29</i> .
	The product is operated at a too high speed.	Refer to <i>To get a good cutting result on page 19</i> .
	The engine speed is too low.	Refer to <i>To get a good cutting result on page 19</i> .
	The cutting deck belt slips.	Speak to your Husqvarna servicing dealer.
	The cutting deck belt is worn or damaged.	Replace the cutting deck belt. Refer to <i>To replace the cutting deck belt (TC 215T) on page 32</i> or <i>To replace the cutting deck belt (TC 215T) on page 32</i> .
The cutting deck does not start when the PTO button is in the engaged position.	There is no grass catcher, or other accessory, installed to the grass discharge (if applicable).	Install the grass catcher, or other accessory, to the grass discharge. Refer to <i>To install and remove the grass catcher on page 14</i> (if applicable).

Transportation, storage and disposal

Transportation

- The product is heavy and can cause crush injuries. Be careful when you load it onto or off a vehicle or trailer.
- Do not lift the product. The anchor points are not approved lifting points and must only be used to attach the product to a trailer.
- Use an approved trailer for transportation of the product.

- Make sure that you have knowledge of local road traffic regulations before transportation of the product in a trailer or on roads.
- To make it easier to load the product onto a trailer, put the cutting deck in the highest position.

To safely attach the product for transportation



WARNING: Before you attach the product, you must read and understand the safety chapter. Refer to *Safety on page 6*.



WARNING: The parking brake is not sufficient to lock the product during transportation. Attach the product tightly to the load area.

Equipment: 2 approved straps and 4 chocks.

1. Park the product in the center of the load area.

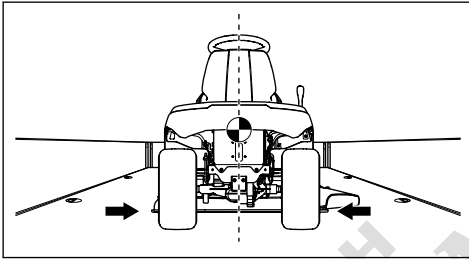

CAUTION: For transportation in transport vehicles with a cover, let the product become cool before you put it below the cover.

2. Make sure that the center of gravity of the product is above the wheel axle of the transport vehicle. If a trailer is used for transportation, make sure that the vertical force on the tow bar is correct.

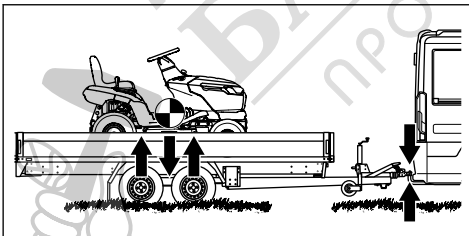

3. Apply the parking brake.
4. Remove all loose objects.

5. Attach the first strap to the tow bar.

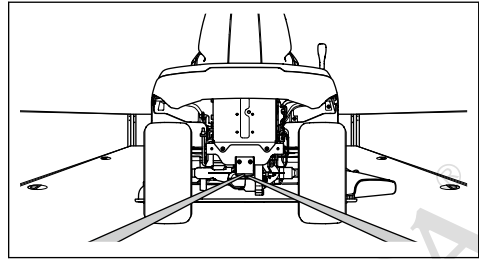

6. Tighten the strap rearward to attach the product to the load area.
7. Put the second strap around the front axle.

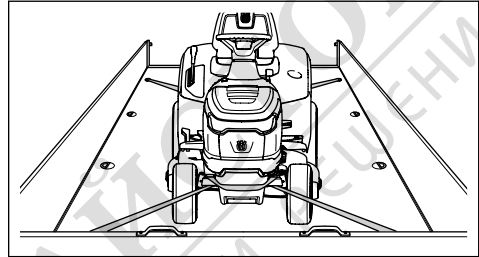

8. Attach the strap to the load area.
9. Tighten the strap in the direction of the front of the load area to attach the product to the load area.
10. Put the chocks in front of and behind the rear wheels.

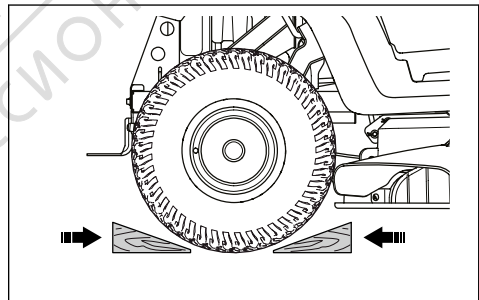

Storage

Prepare the product for storage at the end of the season, and before more than 30 days of storage. If you keep fuel in the fuel tank for 30 days or more, tacky particles can cause blockage in the carburetor. This has a negative effect on the engine function.

To prevent tacky particles during storage, add a stabilizer. If alkylate gasoline is used, stabilizer is not necessary. If you use standard gasoline, do not change to alkylate gasoline. This can cause sensitive rubber parts to become hard. Add stabilizer to the fuel in the tank or in the container used for storage. Always use the mixing ratios given by the manufacturer. Run the engine

for a minimum of 10 minutes after you add the stabilizer until it flows into the carburetor.



WARNING: Do not keep the product with fuel in the tank in an indoor location or in locations with bad airflow. Risk of fire if fuel fumes come near open flames, sparks, or pilot lights in for example boilers, hot water tanks and clothes dryers.



WARNING: Remove grass, leaves and other flammable materials from the product to decrease the risk of fire. Let the product become cool before you put it in storage.

- Clean the product, refer to *To clean the product on page 22*. Repair paint damages to prevent corrosion.
- Examine the product for worn or damaged parts and tighten loose screws and nuts.
- Remove the battery. Clean it, charge it, and keep it cool during storage.
- Change the engine oil, and discard the waste oil.
- Empty the fuel tank. Start the engine and let it operate until there is no remaining fuel in the carburetor.



CAUTION: Do not empty the fuel tank and carburetor if a stabilizer has been added.

- Close the fuel shut-off valve.
- Remove the spark plugs and put approximately a tablespoon of engine oil into each cylinder. Manually turn the engine shaft to apply the oil and put the plugs back on.
- Lubricate all grease nipples, joints and axles.
- Keep the product in a clean and dry area and put a cover on it for more protection.
- A cover for protection of your product during storage or transportation is available at your dealer.

Disposal

- Chemicals can be dangerous and must not be discarded on the ground. Always discard used chemicals at a service center or an applicable disposal location.
- When the product is worn out, send it to the dealer or to an applicable recycling location.
- Oil, oil filters, fuel and the battery can have negative effects on the environment. Obey the local recycling requirements and applicable regulations.
- Do not discard the battery as domestic waste.
- Send the battery to a Husqvarna service agent or discard it at a disposal location for used batteries.

Technical data

Technical data

	TC 215T	TC 220T
Dimensions		
Width, excl. cutting deck, mm	933	971
Width, incl. cutting deck, mm	987.5	1140
Height, mm	1108	1124
Length, excl. grass catcher, mm	1921	2029
Length, incl. grass catcher, mm	2533	2714
Weight, incl. cutting deck, with empty tank, kg	259	284
Grass catcher capacity, l	300	350
Wheel base, mm	1250	1250
Track width, front, mm	756	756
Track width, rear, mm	717	717
Tire pressure, front, kPa/bar/PSI	150/1.5/21.8	150/1.5/21.8
Tire pressure, rear, kPa/bar/PSI	100/1/14.5	100/1/14.5
Front tires	15×6-6	15×6-6
Rear tires	18×8.5-8	20×10-8
Max. gradient, degrees °	10	10
Max. tow equipment weight, at 10° gradient, kg	110	110
Max. permitted vertical load on the tow bar, N/kg	520/52	520/52
Max. permitted horizontal load on the tow bar, N/kg	600/60	600/60
Engine		
Brand / model	Husqvarna / HV 586AE	Husqvarna / HV 708AE
Nominal engine output, kW ¹	11.7	14.4
Displacement, cm ³	586	708
Max. engine speed, rpm	2800 ± 50	2800 ± 50
Max. speed forward, km/h	10	10
Max. speed rearward, km/h	6	6
Fuel, lead-free, maximum ethanol/minimum octance grade	E10/92	E10/92
Fuel tank volume, liters	13	13

¹ The power rating of the engine indicated is the average net output (at specified rpm) of a typical production engine for the engine model measured to SAE standard J1349/ISO1585. Mass production engines may differ from this value. Actual power output for the engine installed on the final product will depend on the operating speed, environmental conditions and other values.

	TC 215T	TC 220T
Oil	Class SF, SH or SJ SAE40, SAE30, SAE20W-50, SAE10W-40, SAE10W-30, or SAE5W-20	Class SF, SH or SJ SAE40, SAE30, SAE20W-50, SAE10W-40, SAE10W-30, or SAE5W-20
Oil volume incl. oil filter, liters	1.7	2.4
Oil volume excl. oil filter, liters	1.6	2.3
Start motor	Electric start, 12 V	Electric start, 12 V
Transmission		
Brand / model	Tuff Torq / K46EN	Tuff Torq / K46EN
Oil volume, liters	2.2	2.2
Electrical system		
Type	12 V, negative grounded	12 V, negative grounded
Battery	12 V, 24 Ah	12 V, 24 Ah
Spark plug	HQT-7/HQT-12	HQT-7/HQT-12
Electrode gap, mm/in.	0.6–0.8/0.024–0.032	0.6–0.8/0.024–0.032
Lamp type	12 V, 10.19 W	12 V, 10.19 W
Cutting deck		
Cutting width, mm	950	1080
Cutting height, 10 positions, mm	25–105	25–105
Noise emissions ²		
Sound power level, measured dB(A)	98	97
Sound power level, guaranteed dB(A)	100	100
Sound levels ³		
Sound pressure level at the operators ear, dB(A)	84	84
Vibration levels ⁴		
Vibration level on the steering wheel, m/s ²	3.8	5.3
Vibration level in the seat, m/s ²	5.5	5.2
Blades		
Blade length, mm	482.5	554
Article number, left blade	537 67 40-10	531 14 83-01
Article number, right blade	537 67 41-10	531 14 83-04

² Noise emissions in the environment measured as sound power (L_{WA}) in conformity with EC directive 2000/14/EC.

³ Noise pressure level according to EN ISO 5395. Reported data for noise pressure level has a typical statistical dispersion (standard deviation) of 3.0 dB(A).

⁴ Vibration level according to EN ISO 5395. Reported data for vibration level has a typical statistical dispersion (standard deviation) of 1.5 m/s² (steering wheel) and 1.5 m/s² (seat).

	TC 215T	TC 220T
Article number, mulch kit (accessory) ⁵	547 35 66-01	546 51 50-01
Article number, left mulch blade (accessory) ⁶	537 67 42-10	534 14 82-99
Article number, right mulch blade (accessory) ⁷	537 67 43-10	531 14 83-02



WARNING: Use only the cutting decks that are specified in this manual. Cutting decks that are not approved for this product can cause objects to eject at high speed and cause serious injury.

Control points	
Parallelism cutting deck with cutting height in position 1	5–10 mm / 0.197–0.394 in.
Control of cutting height in position 1	25 ± 2 mm / 0.98 ± 0.079 in.

Service

Do a yearly check at an authorized service center to make sure that the product functions safely and at its best during high season. The best time to do a servicing or overhaul of the product is low season.

When you send an order for the spare parts, give information about the purchase year, model, type, and serial number.

Always use original spare parts.



⁵ The mulch kit includes blades, mulch plug, and parts for assembly.

⁶ Use the blade only with the complete mulch kit parts in 547 35 66-01 (model TC 215T) or 546 51 50-01 (model TC 220T).

⁷ Use the blade only with the complete mulch kit parts in 547 35 66-01 (model TC 215T) or 546 51 50-01 (model TC 220T).

Declaration of Conformity

EU Declaration of Conformity

We, Husqvarna AB, SE 561 82 Huskvarna, SWEDEN,
Tel. +46 36 146500 declare on our sole responsibility
that the product:

Description	Ride-on lawn mower
Brand	Husqvarna
Type / Model	TC 215T, TC 220T
Identification	Serial number dating 2023 and onwards

complies fully with the following EU directives and regulations:

Directive/Regulation	Description
2006/42/EC	"relating to machinery"
2014/30/EU	"relating to electromagnetic compatibility"
2000/14/EC	"relating to the noise emissions in the environment"
2011/65/EU	"on the restriction of the use of certain hazardous substances in electrical and electronic equipment"

and that the following standards and/or technical specifications are applied; EN ISO 5395-1:2013/A1:2018, EN ISO 5395-3:2013/A1:2017/A2:2018, EN ISO 14982:2009, EN IEC 63000:2018.

Notified body: 0197, TÜV Rheinland LGA Products GmbH, Tillystrasse 2, 90431 Nürnberg, Germany has certified conformity with the council's directive 2000/14/EC, conformity assessment procedure: Annex VI.

For more information relating to noise emissions, refer to *Technical data on page 40*.

Husqvarna, 2024-02-26



Claes Losdal, Development Manager/Garden Products,
Husqvarna AB

Responsible for technical documentation



UK Declaration of Conformity

We, Husqvarna AB, SE-561 82 Huskvarna, Sweden, tel: +46-36-146500, declare on our sole responsibility that the product:

Description	Ride-on lawn mower
Brand	Husqvarna 
Type / Model	TC 215T, TC 220T
Identification	Serial numbers dating from 2023 and onwards

complies fully with the following UK regulations:

Description
The Supply of Machinery (Safety) Regulations 2008
Electromagnetic Compatibility Regulations 2016
The Noise Emission in the Environment by Equipment for use Outdoors Regulations 2001, schedule 9
The Restriction of the Use of Certain Hazardous Substances in Electrical and Electronic Equipment Regulations 2012

and that the following standards and/or technical specifications are applied: EN ISO 5395-1:2013/ A1:2018, EN ISO 5395-3:2013/A1:2017/A2:2018, EN ISO 14982:2009, EN IEC 63000:2018.

UK Importer:
Husqvarna UK Ltd
Preston Road, Co. Durham
DL5 6UP

Approved Body: AnP Certification Limited, 2 Parkfield Street, Rusholme, Manchester, M14 4PN, UK, has carried out certified conformity according to the Outdoor Noise Regulations of 2001, conformity assessment procedure: Schedule 9.

For more information relating to noise emissions, refer to *Technical data on page 40*.

Husqvarna, 2024-02-26



Claes Losdal, Development Manager/Garden Products,
Husqvarna AB

Responsible for technical documentation

**UK
CA**