

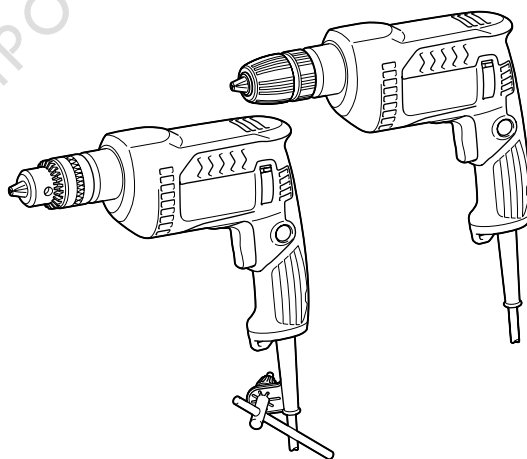

EN	Drill	INSTRUCTION MANUAL	3
FR	Perceuse	MANUEL D'INSTRUCTIONS	7
DE	Bohrmaschine	BETRIEBSANLEITUNG	11
IT	Trapano	ISTRUZIONI PER L'USO	15
NL	Boormachine	GEBRUIKSAANWIJZING	19
ES	Taladro	MANUAL DE INSTRUCCIONES	23
PT	Furadeira	MANUAL DE INSTRUÇÕES	27
EL	Τρυπάνι	ΕΓΧΕΙΡΙΔΙΟ ΟΔΗΓΙΩΝ	31
TR	Matkap	KULLANMA KILAVUZU	35

DP4020
DP4021

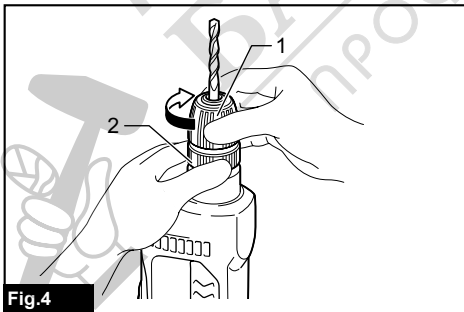

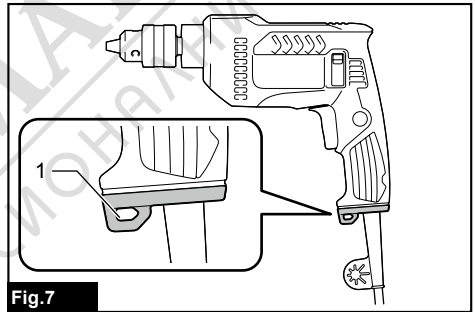
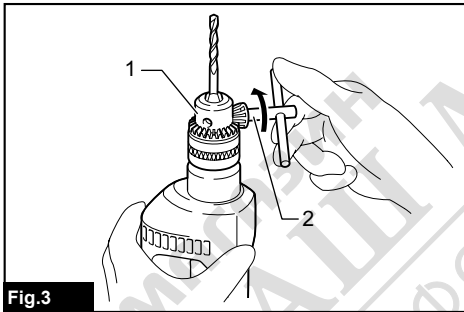
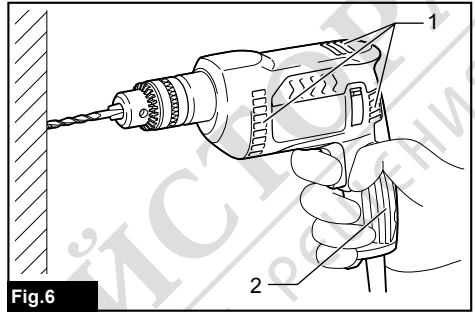
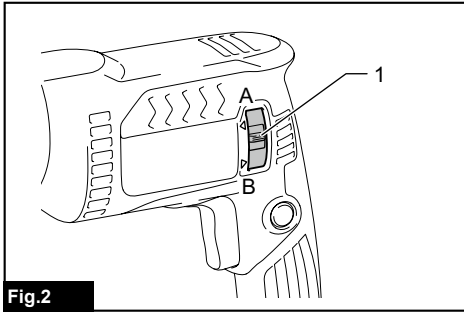
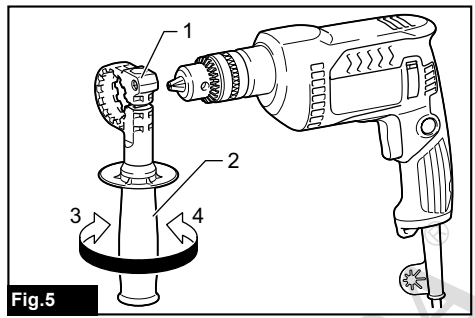
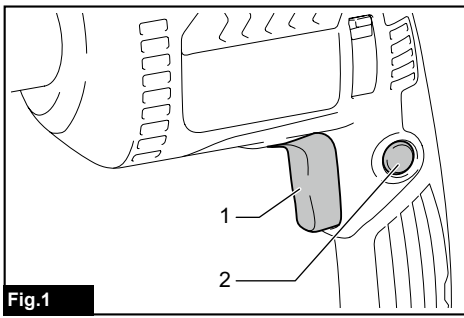

SPECIFICATIONS

Model:		DP4020	DP4021
Drilling capacities	Steel	13 mm	
	Wood	30 mm	
No load speed		0 - 3,000 min ⁻¹	
Overall length		269 mm	271 mm
Net weight		1.7 - 1.9 kg	1.6 - 1.8 kg
Safety class		II/III	

- Due to our continuing program of research and development, the specifications herein are subject to change without notice.
- Specifications may differ from country to country.
- The weight may differ depending on the attachment(s). The lightest and heaviest combinations, according to EPTA-Procedure 01/2014, are shown in the table.

Intended use

The tool is intended for drilling in wood, metal and plastic.

Power supply

The tool should be connected only to a power supply of the same voltage as indicated on the nameplate, and can only be operated on single-phase AC supply. They are double-insulated and can, therefore, also be used from sockets without earth wire.

Noise

The typical A-weighted noise level determined according to EN62841-2-1:

Sound pressure level (L_{pA}): 84 dB (A)

Sound power level (L_{WA}): 92 dB (A)

Uncertainty (K): 3 dB (A)

NOTE: The declared noise emission value(s) has been measured in accordance with a standard test method and may be used for comparing one tool with another.

NOTE: The declared noise emission value(s) may also be used in a preliminary assessment of exposure.

⚠ WARNING: Wear ear protection.

⚠ WARNING: The noise emission during actual use of the power tool can differ from the declared value(s) depending on the ways in which the tool is used especially what kind of workpiece is processed.

⚠ WARNING: Be sure to identify safety measures to protect the operator that are based on an estimation of exposure in the actual conditions of use (taking account of all parts of the operating cycle such as the times when the tool is switched off and when it is running idle in addition to the trigger time).

Vibration

The vibration total value (tri-axial vector sum) determined according to EN62841-2-1:
 Work mode: drilling into metal
 Vibration emission ($a_{h,D}$): 3.5 m/s²
 Uncertainty (K): 1.5 m/s²

NOTE: The declared vibration total value(s) has been measured in accordance with a standard test method and may be used for comparing one tool with another.

NOTE: The declared vibration total value(s) may also be used in a preliminary assessment of exposure.

⚠ WARNING: The vibration emission during actual use of the power tool can differ from the declared value(s) depending on the ways in which the tool is used especially what kind of workpiece is processed.

⚠ WARNING: Be sure to identify safety measures to protect the operator that are based on an estimation of exposure in the actual conditions of use (taking account of all parts of the operating cycle such as the times when the tool is switched off and when it is running idle in addition to the trigger time).

Declarations of Conformity

For European countries only

The Declarations of conformity are included in Annex A to this instruction manual.

SAFETY WARNINGS

General power tool safety warnings

⚠ WARNING Read all safety warnings, instructions, illustrations and specifications provided with this power tool. Failure to follow all instructions listed

below may result in electric shock, fire and/or serious injury.

Save all warnings and instructions for future reference.

The term "power tool" in the warnings refers to your mains-operated (corded) power tool or battery-operated (cordless) power tool.

Drill safety warnings

Safety instructions for all operations

1. **Hold the power tool by insulated gripping surfaces, when performing an operation where the cutting accessory may contact hidden wiring or its own cord.** Cutting accessory contacting a "live" wire may make exposed metal parts of the power tool "live" and could give the operator an electric shock.
2. **Always be sure you have a firm footing. Be sure no one is below when using the tool in high locations.**
3. **Hold the tool firmly.**
4. **Keep hands away from rotating parts.**
5. **Do not leave the tool running. Operate the tool only when hand-held.**
6. **Do not touch the drill bit, the workpiece or chips immediately after operation; they may be extremely hot and could burn your skin.**
7. **Some material contains chemicals which may be toxic. Take caution to prevent dust inhalation and skin contact. Follow material supplier safety data.**
8. **If the drill bit cannot be loosened even you open the jaws, use pliers to pull it out.** In such a case, pulling out the drill bit by hand may result in injury by its sharp edge.
9. **Make sure there are no electrical cables, water pipes, gas pipes etc. that could cause a hazard if damaged by use of the tool.**

Safety instructions when using long drill bits

1. **Never operate at higher speed than the maximum speed rating of the drill bit.** At higher speeds, the bit is likely to bend if allowed to rotate freely without contacting the workpiece, resulting in personal injury.
2. **Always start drilling at low speed and with the bit tip in contact with the workpiece.** At higher speeds, the bit is likely to bend if allowed to rotate freely without contacting the workpiece, resulting in personal injury.
3. **Apply pressure only in direct line with the bit and do not apply excessive pressure.** Bits can bend causing breakage or loss of control, resulting in personal injury.

SAVE THESE INSTRUCTIONS.

⚠WARNING: DO NOT let comfort or familiarity with product (gained from repeated use) replace strict adherence to safety rules for the subject product. MISUSE or failure to follow the safety rules stated in this instruction manual may cause serious personal injury.

FUNCTIONAL DESCRIPTION

⚠CAUTION: Always be sure that the tool is switched off and unplugged before adjusting or checking function on the tool.

Switch action

⚠WARNING: Before plugging in the tool, always check to see that the switch trigger actuates properly and returns to the "OFF" position when released.

To start the tool, simply pull the switch trigger. Tool speed is increased by increasing pressure on the switch trigger. Release the switch trigger to stop.

For continuous operation, pull the switch trigger, push in the lock button and then release the switch trigger. To stop the tool from the locked position, pull the switch trigger fully, then release it.

► Fig. 1: 1. Switch trigger 2. Lock button

Reversing switch action

⚠CAUTION: Always check the direction of rotation before operation.

NOTICE: Use the reversing switch only after the tool comes to a complete stop. Changing the direction of rotation before the tool stops may damage the tool.

NOTICE: When changing the direction of rotation, be sure to fully set the reversing switch to position A side or B side. Otherwise, when the switch trigger is pulled, the motor may not rotate or the tool may not work properly.

This tool has a reversing switch to change the direction of rotation. Move the reversing switch lever to the position A side (◁) for clockwise rotation or to the position B side (▷) for counterclockwise rotation.

► Fig. 2: 1. Reversing switch lever

ASSEMBLY

Installing or removing drill bit

⚠CAUTION: Always be sure that the tool is switched off and unplugged before installing or removing the drill bit.

For model DP4020

To install the drill bit, place it in the drill chuck as far as it will go. Tighten the chuck by hand. Place the chuck key in each of the three holes and tighten clockwise. Be sure to tighten all three chuck holes evenly.

To remove the drill bit, turn the drill chuck key counterclockwise in just one hole, then loosen the chuck by hand.

After using the chuck key, be sure to return it to the original position.

► **Fig.3:** 1. Drill chuck 2. Chuck key

For model DP4021

Hold the ring and turn the sleeve counterclockwise to open the chuck jaws. Place the drill bit in the drill chuck as far as it will go. Hold the ring firmly and turn the sleeve clockwise to tighten the chuck.

To remove the drill bit, hold the ring and turn the sleeve counterclockwise.

► **Fig.4:** 1. Sleeve 2. Ring

Installing or removing side grip (auxiliary handle)

Optional accessory

CAUTION: Always be sure that the tool is switched off and unplugged before installing or removing the side grip.

CAUTION: Make sure that the side grip is securely tightened before operation.

The side grip ensures safe operation. Loosen the grip to open the grip base and fit into the tool. Then tighten the grip at the desired position. It may be swung 360° so as to be secured at any position.

To remove the side grip, follow the installation procedure in reverse.

► **Fig.5:** 1. Grip base 2. Side grip 3. Loosen 4. Tighten

OPERATION

CAUTION: Switch off the tool immediately if the tool malfunctions, foreign matter enter the tool, or abnormal noises are heard. Contact Makita service center or your local dealer to have the tool serviced or repaired.

Holding the tool

Hold the tool firmly with one hand on the grip. In the case of the twisting action, hold the grip firmly with both hands.

► **Fig.6:** 1. Vent 2. Grip

NOTICE: Do not cover vents, or it may cause overheating and damage to the tool.

Drilling operation

CAUTION: Pressing excessively on the tool will not speed up the drilling. In fact, this excessive pressure will only serve to damage the tip of your drill bit, decrease the tool performance and shorten the service life of the tool.

CAUTION: Hold the tool firmly and exert care when the drill bit begins to break through the workpiece. There is a tremendous force exerted on the tool/drill bit at the time of hole break through.

CAUTION: A stuck drill bit can be removed simply by setting the reversing switch to reverse rotation in order to back out. However, the tool may back out abruptly if you do not hold it firmly.

CAUTION: Always secure workpieces in a vise or similar hold-down device.

Drilling in wood

When drilling in wood, the best results are obtained with wood drills equipped with a guide screw. The guide screw makes drilling easier by pulling the drill bit into the workpiece.

Drilling in metal

To prevent the drill bit from slipping when starting a hole, make an indentation with a center-punch and hammer at the point to be drilled. Place the point of the drill bit in the indentation and start drilling. Use a cutting lubricant when drilling metals. The exceptions are iron and brass which should be drilled dry.

Storage

CAUTION: Use the hanging hole for their intended purposes only. Using for unintended purpose may cause accident or personal injury.

The hook hole in the tool bottom is convenient for hanging the tool from a nail or screw on the wall. Store the tool out of the reach of children. Store the tool in a place not exposed to moisture or rain.

► **Fig.7:** 1. Hole

MAINTENANCE

CAUTION: Always be sure that the tool is switched off and unplugged before attempting to perform inspection or maintenance.

NOTICE: Never use gasoline, benzine, thinner, alcohol or the like. Discoloration, deformation or cracks may result.

To maintain product SAFETY and RELIABILITY, repairs, any other maintenance or adjustment should be performed by Makita Authorized or Factory Service Centers, always using Makita replacement parts.

OPTIONAL ACCESSORIES

⚠ CAUTION: These accessories or attachments are recommended for use with your Makita tool specified in this manual. The use of any other accessories or attachments might present a risk of injury to persons. Only use accessory or attachment for its stated purpose.

If you need any assistance for more details regarding these accessories, ask your local Makita Service Center.

- Drill bits
- Side grip

NOTE: Some items in the list may be included in the tool package as standard accessories. They may differ from country to country.



МАГАЗИН
БАШ МАЙСТОРА®
ПРОФЕСИОНАЛНИ РЕШЕНИЯ