

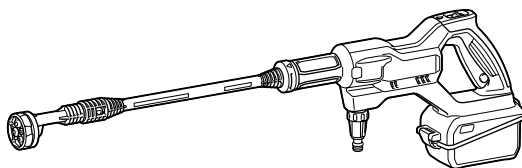

EN	Cordless Pressure Washer	INSTRUCTION MANUAL	8
FR	Nettoyeur haute pression sans fil	MANUEL D'INSTRUCTIONS	19
DE	Akku-Druckreiniger	BETRIEBSANLEITUNG	32
IT	Idropulitrice a pressione a batteria	ISTRUZIONI PER L'USO	46
NL	Accuwaterspuit	GEBRUIKSAANWIJZING	60
ES	Hidrolavadora Inalámbrica de Presión	MANUAL DE INSTRUCCIONES	73
PT	Lavadora de Alta Pressão Portátil a Bateria	MANUAL DE INSTRUÇÕES	86
EL	Φορητό πλυστικό μηχάνημα πίεσης	ΕΓΧΕΙΡΙΔΙΟ ΟΔΗΓΙΩΝ	99
TR	Akülü Basınçlı Yıkama Makinası	KULLANMA KILAVUZU	113
ZHTW	充電式清洗機	使用說明書	124

DHW180

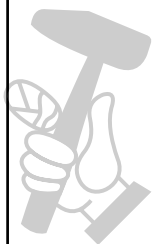

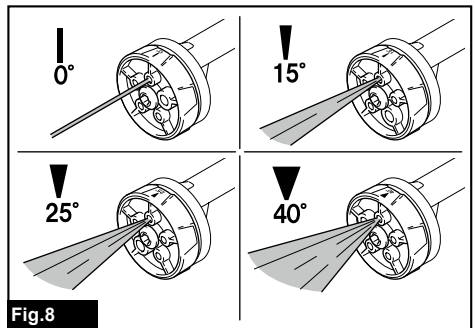
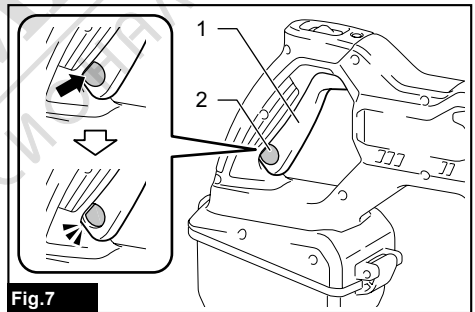
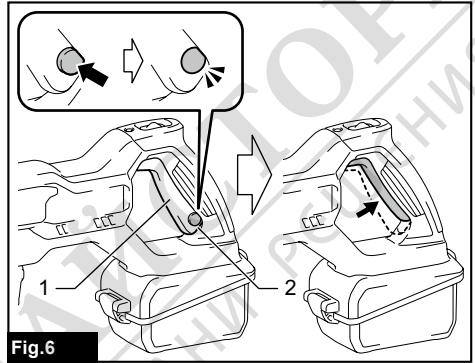
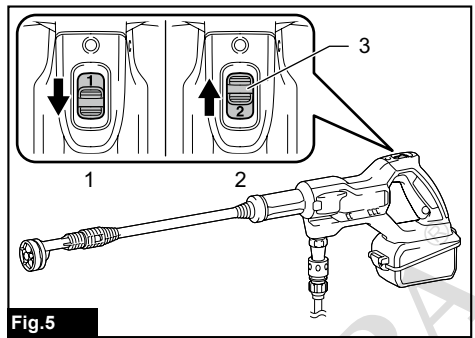
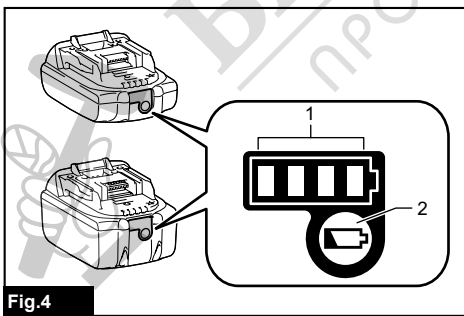
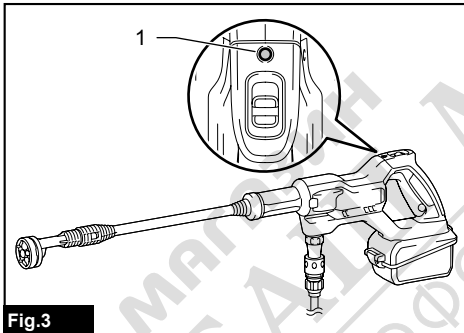
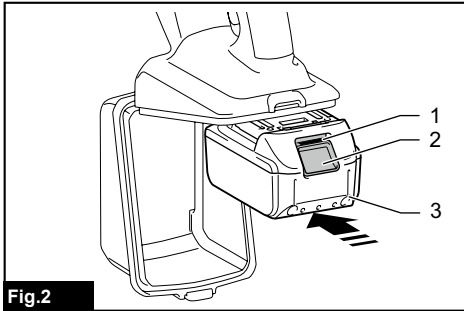
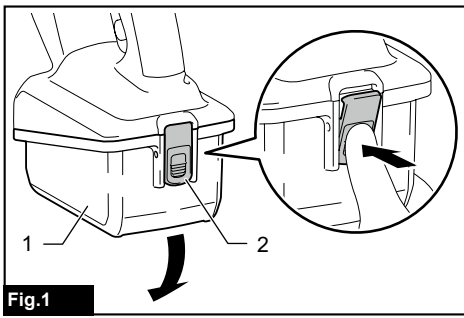

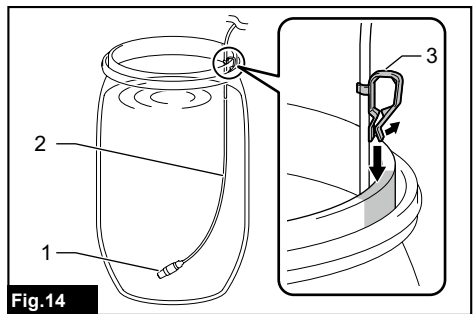
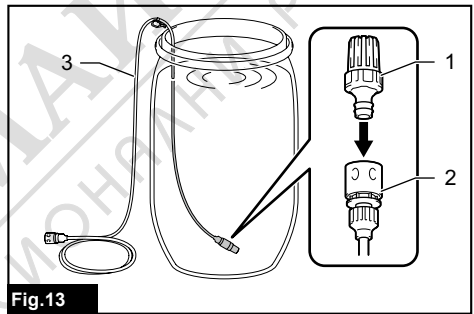
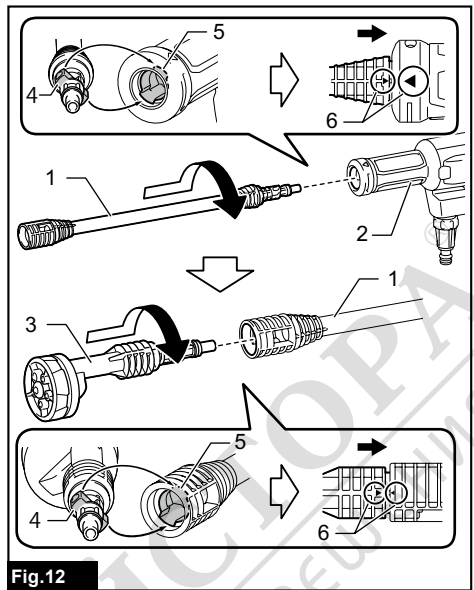
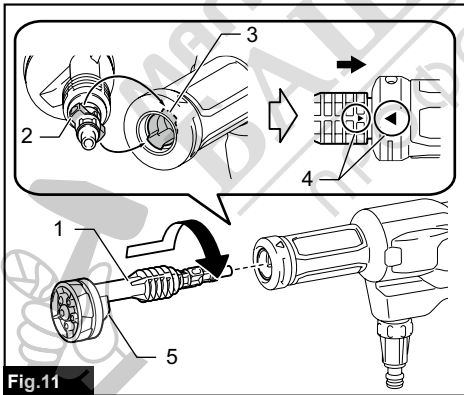
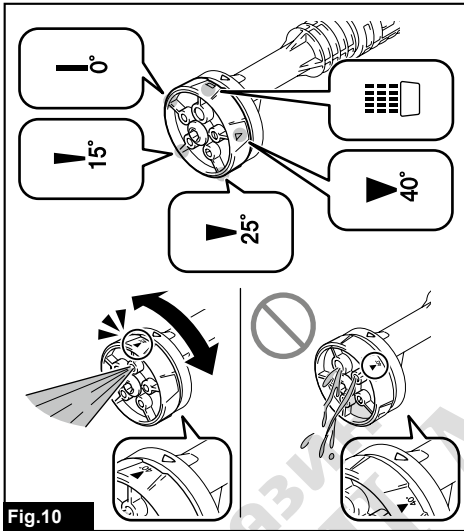
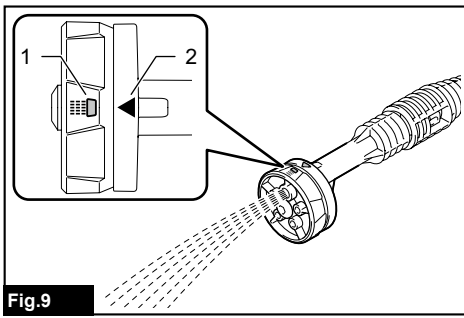

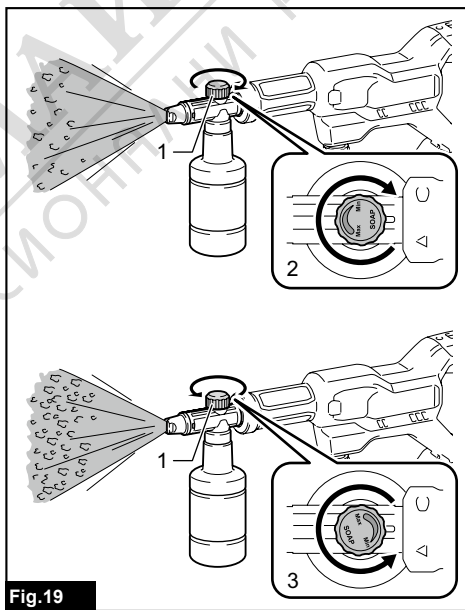
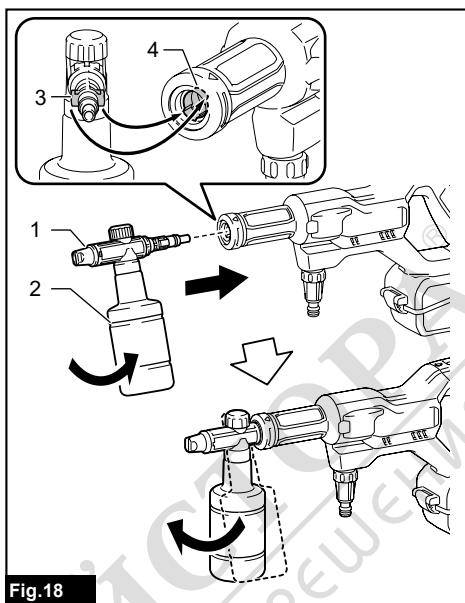
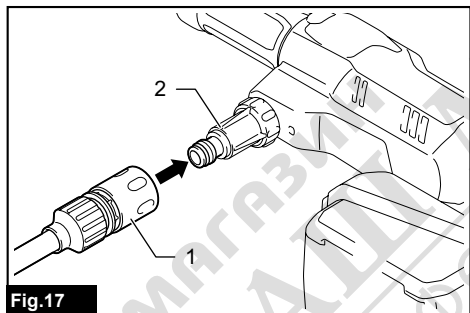
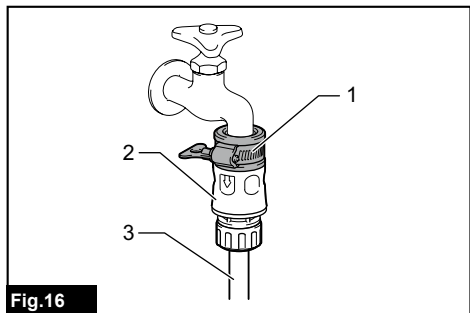
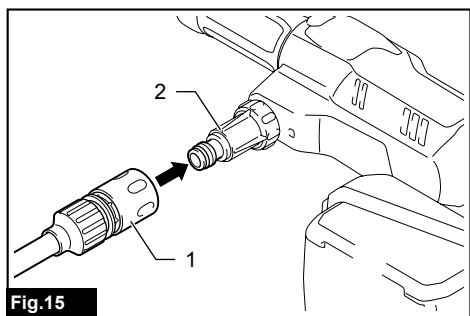

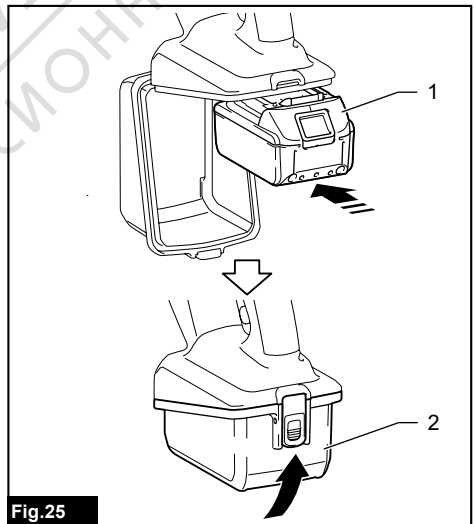
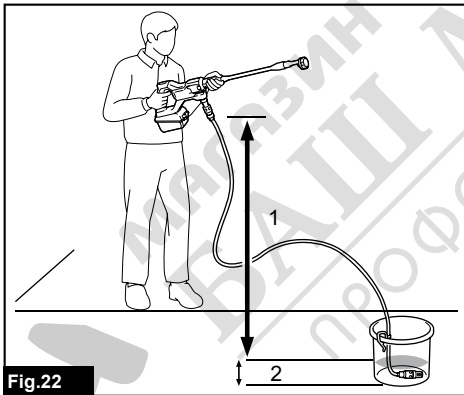
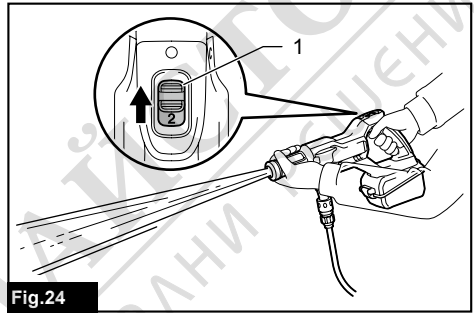
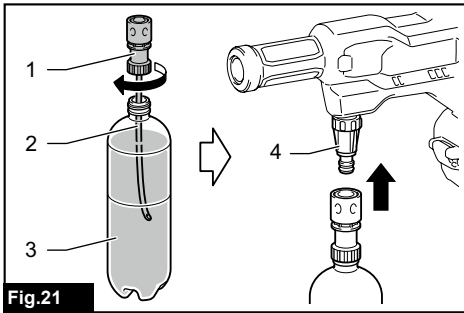
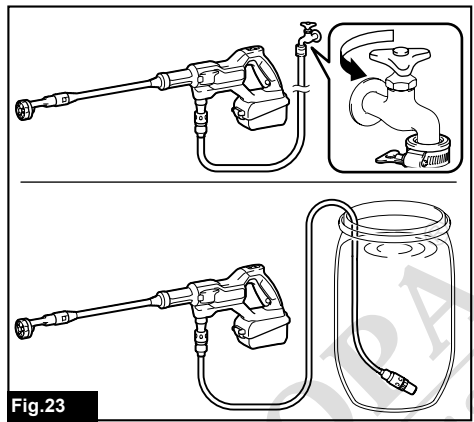
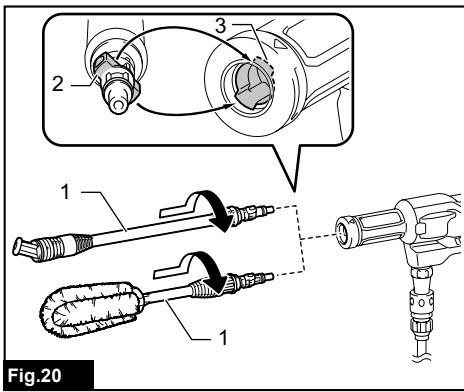

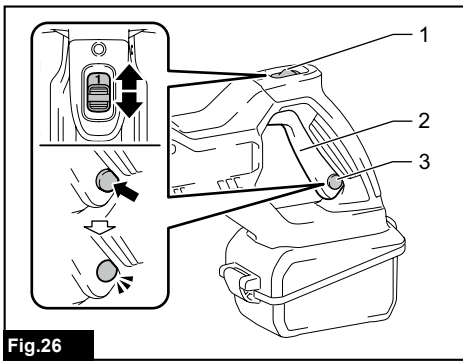

Fig.26

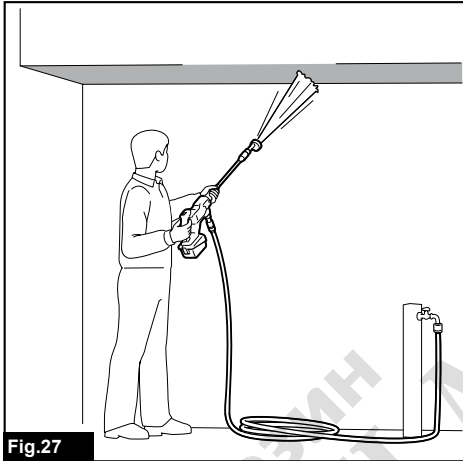

Fig.27



Fig.28

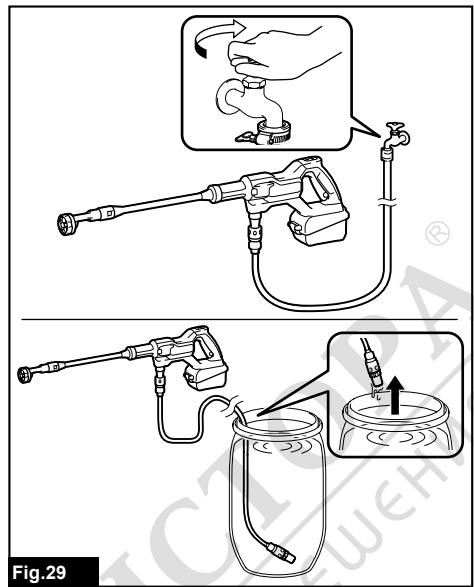

Fig.29

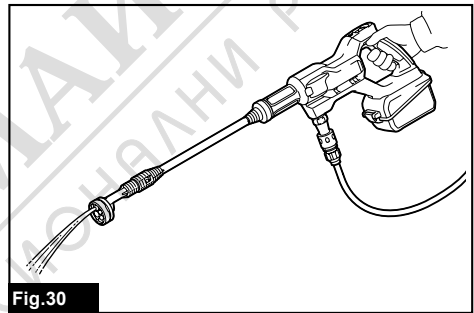

Fig.30

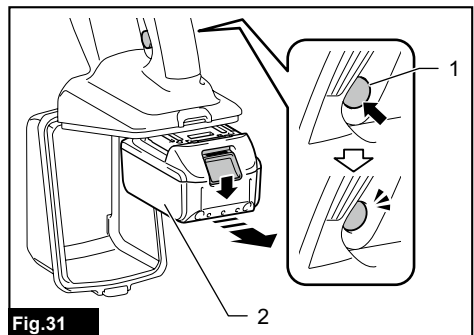
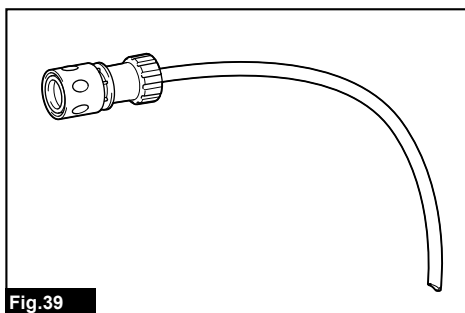
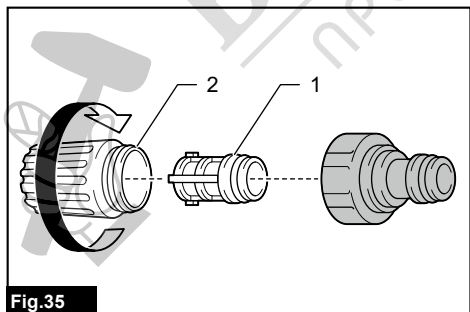
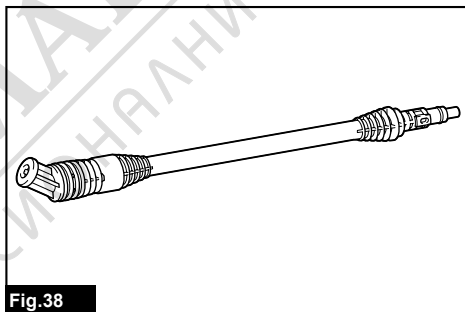
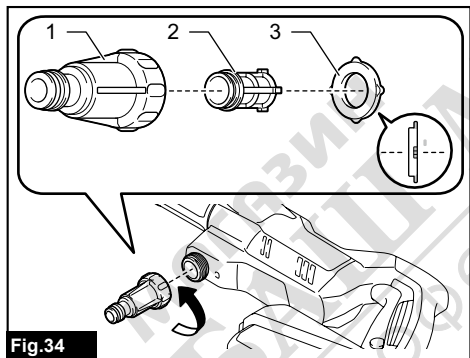
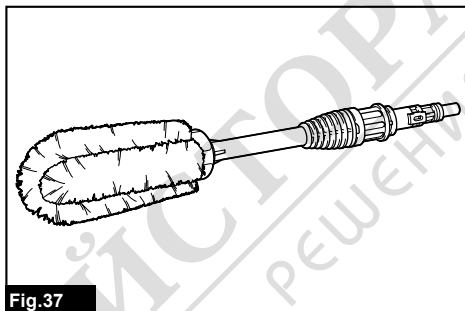
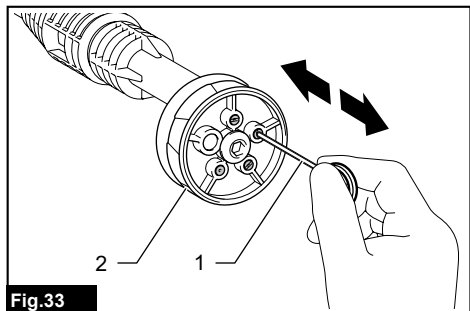
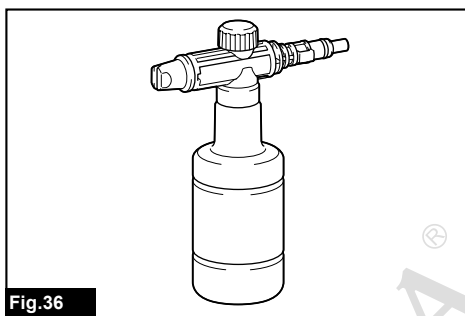
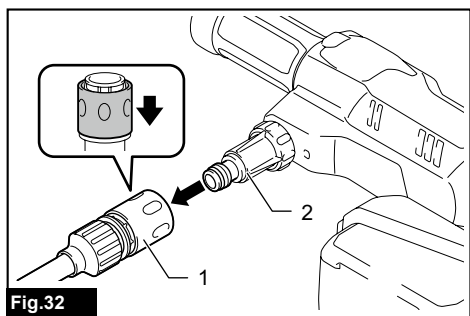

Fig.31



WARNING

- Appliance shall not be used by children. Children should be supervised to ensure that they do not play with the appliance.
- This appliance is not intended for use by persons (including children) with reduced physical, sensory or mental capabilities, or lack of experience and knowledge, unless they have been given supervision or instruction concerning use of the appliance by a person responsible for their safety.
- Pressure water must not be directed at persons, live electrical equipment or the appliance itself.
- Always be sure that the appliance is switched off and battery cartridge is removed before carrying out any work on the tool.
- Do not use the appliance if important parts of the appliance are damaged, e.g. safety devices, pressure hoses.
- Read instructions in the maintenance section for the appropriate details of precautions during user maintenance.
- Learn the normal temperature range for charging battery. Read safety instructions for battery cartridge to learn precautions of handling batteries.
- Read instructions in the assembly section for the appropriate details of precautions during installation of the appliance.
- Learn the maximum inlet water pressure. Read information in the specifications section for the appropriate details on connection to water mains.
- Always use the hose-sets supplied with the appliance. Read instructions in the assembly section to learn precautions for connection to water mains.
- The water filling aperture should not be opened during use. Follow the instructions in the assembly section to maintain water pressure.
- Do not use in swimming pools containing water.
- Comply with the requirements of the local water supply company.
- For European countries:
According to EN12729 (BA), the appliance can also be

connected to the mains drinking water supply if a backflow preventer valve with drain facility is installed in the supply hose.

SPECIFICATIONS

Model:		DHW180
Max. flow rate ^{*1} [Tank water supply / Mains water supply]		3.0 / 5.3 L/min
Water flow rate ^{*2}	High mode	2.5 L/min
	Low mode	1.5 L/min
Max. working pressure		2.4 MPa
Working pressure ^{*2}	High mode [Tank water supply / Mains water supply]	2.0 / 2.2 MPa
	Low mode [Tank water supply / Mains water supply]	0.8 / 0.8 MPa
Max. feed pressure		0.5 MPa
Max. feed temperature		40°C
Max. suction height		2.0 m
Rated voltage		D.C. 18 V
Dimensions ^{*3}		888 mm x 99 mm x 239 mm
[L x W x H]		
Weight		2.3 - 2.7kg

*1 : Without nozzle

*2 : Spray pattern 15°

*3 : With 5in1 nozzle and extension

- Due to our continuing program of research and development, the specifications herein are subject to change without notice.
- Specifications may differ from country to country.
- The weight may differ depending on the attachment(s), including the battery cartridge. The lightest and heaviest combination are shown in the table.

Applicable battery cartridge and charger

Battery cartridge	BL1815N / BL1820B / BL1830B / BL1840B / BL1850B / BL1860B
Charger	DC18RC / DC18RD / DC18RE / DC18SD / DC18SE / DC18SF / DC18SH / DC18WC

- Some of the battery cartridges and chargers listed above may not be available depending on your region of residence.

⚠ WARNING: Only use the battery cartridges and chargers listed above. Use of any other battery cartridges and chargers may cause injury and/or fire.

⚠ WARNING: Do not use a corded power supply such as battery adapter or portable power pack with this machine. The cable of such power supply may hinder the operation and result in personal injury.

Symbols



Take particular care and attention.

The followings show the symbols which may be used for the equipment. Be sure that you understand their meaning before use.



Read the instruction manual.



Only for EU countries
Due to the presence of hazardous components in the equipment, waste electrical and electronic equipment, accumulators and batteries may have a negative impact on the environment and human health. Do not dispose of electrical and electronic appliances or batteries with household waste!

In accordance with the European Directive on waste electrical and electronic equipment and on accumulators and batteries and waste accumulators and batteries, as well as their adaptation to national law, waste electrical equipment, batteries and accumulators should be stored separately and delivered to a separate collection point for municipal waste, operating in accordance with the regulations on environmental protection.

This is indicated by the symbol of the crossed-out wheeled bin placed on the equipment.



Do not connect to a potable water faucet.



Do not direct the jet at people including yourself, animals, and live electrical equipment.

Intended use

This tool is intended to clean dirt by using water jet for household use. By offering selectable spray type, the tool functions to improve your washing as well as lawn and garden watering.

SAFETY WARNINGS

IMPORTANT SAFETY WARNINGS

⚠ WARNING: Read all safety warnings and all instructions. Failure to follow the warnings and instructions may result in electric shock, fire and/or serious injury.

Save all warnings and instructions for future reference.

WARNING – When using this product, basic precautions should always be followed, including the following:

Work area safety

1. Keep operating area clear of all persons.
2. Do not overreach or stand on unstable supports. Keep good footing and balance at all times.
3. Always place the pressure washer body on a level and stable surface. Avoid areas where the ejected water will run or pool.
4. Before cleaning, check the surroundings and objects to be cleaned. Pressure jets can scrape away paint or other surface treatments including toxic chemicals. Take the preventive

measures if necessary.

5. Be careful not to trip over by the hose of the pressure washer. Always be aware of the configuration of the hose during operation.
6. During use, a small amount of water will come out from the bottom of the pressure washer. Be careful not to operate the tool above the areas where you do not want them to be wet.

Personal safety

1. To protect against the jet and objects by the jet, operators should wear appropriate clothing such as safety boots, safety gloves, safety helmets with visors, hearing protection, etc.
2. Wear personal protective equipment. Depending on application, use face shield, safety goggles or safety glasses as eye protection is capable of stopping flying debris generated by various operations.
3. Do not use the pressure washer within range of persons unless they wear protective clothing.
4. To reduce the risk of injury, close supervision is necessary when the product is used near children.
5. If connection is made to a potable water system, the system shall be protected against backflow.
6. Water that has flowed through backflow preventer is considered to be non-potable.

Electrical safety

1. Never touch battery cartridges with wet hands.
2. Do not use the appliance if the important parts of the appliance are damaged, e.g. safety devices, pressure hoses.
3. Avoid dangerous environment. Don't use the tool in damp or wet locations or expose it to rain. Water entering the tool will increase the risk of electric shock.

Power tool use and care

1. Read all the instructions before using the product.
2. Know how to stop the pressure washer and bleed pressures quickly. Be thoroughly familiar with the controls.
3. Do not spray flammable and/or toxic liquids. This may cause an explosion, intoxication, or damage to the appliance.
4. Do not direct the jet against yourself or others in order to clean clothes or footwear.
5. Pressure hoses, fittings and couplings are important for the safety of the appliance. Use only hoses, fittings and couplings recommended by the manufacturer.
6. Follow the instructions when changing accessories.
7. Keep handles dry, clean, and free of oil or grease.
8. Stay alert – watch what you are doing.
9. Do not operate the product when fatigued or under the influence of alcohol or drugs.
10. Do not run the pressure washer without water for longer than one minute. It will damage the motor, resulting in malfunction.

11. **Always turn off the power and shut off the water mains when leaving the pressure washer unattended.**
12. **Be wary of the kickback. The appliance recoils when the pressure jet is ejected from the nozzle. Hold the appliance firmly to prevent accidental injuries.**
13. **Check for damaged or worn parts before use. Also make sure that the hose is properly connected and there is no leakage during operation. Operating the appliance with functional defects may cause an accident.**
14. **Do not pull the hose to move the pressure washer body. This will damage the hose and connecting parts and result in a short circuit or functional defects.**
15. **Do not put heavy objects on the hose or let vehicles drive over it.**
16. **Always discharge the residual pressure in the appliance before disconnecting the hose.**
17. **When connecting the hose to the water mains, observe the instructions of your local waterworks department or company.**
18. **If the pressure washer is dropped or hits against a hard object, be sure to check for damage and crack. Using the pressure washer damaged may generate smoke, fire, or cause electric shock, which result in personal injury.**
19. **Prevent unintentional starting. Ensure the switch is in the off-position before connecting to battery pack, picking up or carrying the appliance. Carrying the appliance with your finger on the switch or energizing appliance that have the switch on invites accidents.**
20. **Disconnect the battery pack from the appliance before making any adjustments, changing accessories, or storing appliance. Such preventive safety measures reduce the risk of starting the appliance accidentally.**
21. **Do not modify or attempt to repair the appliance or the battery pack except as indicated in the instructions for use and care.**
22. **WARNING – Risk of Injection or Injury– Do Not Direct Discharge Stream At Persons.**
23. **Be sure that an object or area to be cleaned is durable against watering. Otherwise may cause damage to the item or site resulting in personal injury.**

Battery tool use and care

1. **Recharge only with the charger specified by the manufacturer. A charger that is suitable for one type of battery pack may create a risk of fire when used with another battery pack.**
2. **Use power tools only with specifically designated battery packs. Use of any other battery packs may create a risk of injury and fire.**
3. **When battery pack is not in use, keep it away from other metal objects, like paper clips, coins, keys, nails, screws or other small metal objects, that can make a connection from one terminal to another. Shorting the battery terminals together may cause burns or a fire.**
4. **Under abusive conditions, liquid may be ejected from the battery; avoid contact. If contact accidentally occurs, flush with water. If liquid contacts eyes, additionally seek medical help. Liquid ejected from the battery may cause irritation or burns.**
5. **Do not use a battery pack or tool that is damaged or modified. Damaged or modified batteries may exhibit unpredictable behaviour resulting in fire, explosion or risk of injury.**
6. **Do not expose a battery pack or tool to fire or excessive temperature. Exposure to fire or temperature above 130 °C may cause explosion.**
7. **Follow all charging instructions and do not charge the battery pack or tool outside the temperature range specified in the instructions. Charging improperly or at temperatures outside the specified range may damage the battery and increase the risk of fire.**

Service

1. **Follow the maintenance instructions specified in the manual.**
2. **To ensure appliance safety, use only original spare parts from the manufacturer or approved by the manufacturer.**
3. **Have your pressure washer serviced by a qualified repair person using only identical replacement parts. This will ensure that the safety of the pressure washer is maintained.**
4. **In case of breakdown or malfunction of the pressure washer, immediately switch it off and remove the battery cartridge(s). Contact your local dealer or service center.**

Additional safety warnings

1. **Do not use the tool when there is a risk of lightning.**
2. **When you use the tool on muddy ground, wet slope, or slippery place, pay attention to your footing.**
3. **Avoid working in poor environment where increased user fatigue is expected.**
4. **Do not replace the battery in the rain.**
5. **Do not submerge the tool into a puddle.**
6. **When storing the tool, avoid direct sunlight and rain, and store it in a place where it does not get hot or humid.**
7. **After using the tool, remove the adhered dirt and dry the tool completely before storing. Depending on the season or the area, there is a risk of malfunction due to freezing.**
8. **Do not wet the terminal of battery with liquid such as water, or submerge the battery. Do not leave the battery in the rain, nor charge, use, or store the battery in a damp or wet place. If the terminal gets wet or liquid enters inside of battery, the battery may be short circuited and there is a risk of overheat, fire, or explosion.**
9. **After removing the battery from the tool or charger, be sure to attach the battery cover to the battery and store it in a dry place.**
10. **Do not replace the battery with wet hands.**
11. **If the appliance is frozen due to cold weather, contact an authorized service center for repairs.**
12. **Do not use a corded power supply such as**

battery adapter or portable power pack with this appliance. The cable of such power supply may hinder the operation and result in personal injury.

SAVE THESE INSTRUCTIONS.

⚠WARNING: DO NOT let comfort or familiarity with product (gained from repeated use) replace strict adherence to safety rules for the subject product.

MISUSE or failure to follow the safety rules stated in this instruction manual may cause serious personal injury.

Important safety instructions for battery cartridge

1. Before using battery cartridge, read all instructions and cautionary markings on (1) battery charger, (2) battery, and (3) product using battery.
2. Do not disassemble or tamper with the battery cartridge. It may result in a fire, excessive heat, or explosion.
3. If operating time has become excessively shorter, stop operating immediately. It may result in a risk of overheating, possible burns and even an explosion.
4. If electrolyte gets into your eyes, rinse them out with clear water and seek medical attention right away. It may result in loss of your eyesight.
5. Do not short the battery cartridge:
 - (1) Do not touch the terminals with any conductive material.
 - (2) Avoid storing battery cartridge in a container with other metal objects such as nails, coins, etc.
 - (3) Do not expose battery cartridge to water or rain.

A battery short can cause a large current flow, overheating, possible burns and even a breakdown.

6. Do not store and use the tool and battery cartridge in locations where the temperature may reach or exceed 50 °C (122 °F).
7. Do not incinerate the battery cartridge even if it is severely damaged or is completely worn out. The battery cartridge can explode in a fire.
8. Do not nail, cut, crush, throw, drop the battery cartridge, or hit against a hard object to the battery cartridge. Such conduct may result in a fire, excessive heat, or explosion.
9. Do not use a damaged battery.
10. The contained lithium-ion batteries are subject to the Dangerous Goods Legislation requirements.

For commercial transports e.g. by third parties, forwarding agents, special requirement on packaging and labeling must be observed.

For preparation of the item being shipped, consulting an expert for hazardous material is required. Please also observe possibly more detailed

national regulations.

Tape or mask off open contacts and pack up the battery in such a manner that it cannot move around in the packaging.

11. When disposing the battery cartridge, remove it from the tool and dispose of it in a safe place. Follow your local regulations relating to disposal of battery.
12. Use the batteries only with the products specified by Makita. Installing the batteries to non-compliant products may result in a fire, excessive heat, explosion, or leak of electrolyte.
13. If the tool is not used for a long period of time, the battery must be removed from the tool.
14. During and after use, the battery cartridge may take on heat which can cause burns or low temperature burns. Pay attention to the handling of hot battery cartridges.
15. Do not touch the terminal of the tool immediately after use as it may get hot enough to cause burns.
16. Do not allow chips, dust, or soil stuck into the terminals, holes, and grooves of the battery cartridge. It may cause heating, catching fire, burst and malfunction of the tool or battery cartridge, resulting in burns or personal injury.
17. Unless the tool supports the use near high-voltage electrical power lines, do not use the battery cartridge near high-voltage electrical power lines. It may result in a malfunction or breakdown of the tool or battery cartridge.
18. Keep the battery away from children.

SAVE THESE INSTRUCTIONS.

⚠CAUTION: Only use genuine Makita batteries. Use of non-genuine Makita batteries, or batteries that have been altered, may result in the battery bursting causing fires, personal injury and damage. It will also void the Makita warranty for the Makita tool and charger.

Tips for maintaining maximum battery life

1. Charge the battery cartridge before completely discharged. Always stop tool operation and charge the battery cartridge when you notice less tool power.
2. Never recharge a fully charged battery cartridge. Overcharging shortens the battery service life.
3. Charge the battery cartridge with room temperature at 10 °C - 40 °C (50 °F - 104 °F). Let a hot battery cartridge cool down before charging it.
4. When not using the battery cartridge, remove it from the tool or the charger.
5. Charge the battery cartridge if you do not use it for a long period (more than six months).

FUNCTIONAL DESCRIPTION

CAUTION: Always be sure that the tool is switched off and the battery cartridge is removed before adjusting or checking function on the tool.

Installing or removing battery cartridge

CAUTION: Always switch off the tool before installing or removing of the battery cartridge.

CAUTION: Hold the tool and the battery cartridge firmly when installing or removing battery cartridge. Failure to hold the tool and the battery cartridge firmly may cause them to slip off your hands and result in damage to the tool and battery cartridge and a personal injury.

CAUTION: Be careful not to pinch your fingers when opening or closing the battery cover.

Open the cover while pushing the lock lever.

► Fig.1: 1. Cover 2. Lock lever

Align the tongue on the battery cartridge with the groove in the housing and slip it into place. Insert it all the way until it locks in place with a little click. If you can see the red indicator as shown in the figure, it is not locked completely.

► Fig.2: 1. Red indicator 2. Button 3. Battery cartridge

After installing or removing the battery cartridges, be sure to close the cover.

To remove the battery cartridge, open the cover, slide the battery cartridge off the tool while pushing down the button on front, then close the cover.

CAUTION: Always install the battery cartridge fully until the red indicator cannot be seen. If not, it may accidentally fall out of the tool, causing injury to you or someone around you.

CAUTION: Do not install the battery cartridge forcibly. If the cartridge does not slide in easily, it is not being inserted correctly.

CAUTION: Be sure to lock the cover before operating.

Tool / battery protection system

The tool is equipped with a tool/battery protection system. This system automatically cuts off power to the motor to extend tool and battery life. The tool will automatically stop with indication if the tool or battery is placed under one of the following conditions:

► Fig.3: 1. Indicator

Overload protection

When the tool or battery is operated in a manner that causes it to draw an abnormally high current, the tool automatically stops and the red indicator lights up. In this situation, turn the tool off and stop the application

that caused the tool to become overloaded. Then turn the tool on to restart.

Overheat protection

When the tool or battery is overheated, the tool stops automatically and the red indicator lights up. In this situation, let the tool cool down before turning the tool on again.

Overdischarge protection

When the battery capacity becomes low, the red indicator blinks. When the battery becomes close to empty, the tool stops automatically and the red indicator lights up. In this case, remove the battery from the tool and charge the battery.

Protections against other causes

Protection system is also designed for other causes that could damage the tool and allows the tool to stop automatically. Take all the following steps to clear the causes, when the tool has been brought to a temporary halt or stop in operation.

1. Turn the tool off, and then turn it on again to restart.
2. Charge the battery(ies) or replace it/them with recharged battery(ies).
3. Let the tool and battery(ies) cool down.

If no improvement can be found by restoring protection system, then contact your local Makita Service Center.

NOTICE: If the tool stops due to a cause not described above, refer to the section for troubleshooting.

Indicating the remaining battery capacity

Only for battery cartridges with the indicator

Press the check button on the battery cartridge to indicate the remaining battery capacity. The indicator lamps light up for a few seconds.

► Fig.4: 1. Indicator lamps 2. Check button

Indicator lamps			Remaining capacity
Lighted	Off	Blinking	
■	■	■	75% to 100%
■	■	■	50% to 75%
■	■	□	25% to 50%
■	□	□	0% to 25%
◐	□	□	Charge the battery.
■	■	□	The battery may have malfunctioned.
□	□	■	

NOTE: Depending on the conditions of use and the ambient temperature, the indication may differ slightly from the actual capacity.

NOTE: The first (far left) indicator lamp will blink when the battery protection system works.

Pressure mode switch

Select your desired pressure mode by sliding the switch lever forwards and backwards.

Pull the lever backwards for low pressure mode so a number symbol "1" reads on the switch.

Push the lever forwards for high pressure mode so a number symbol "2" reads on the switch.

► **Fig.5:** 1. Low pressure mode (1) 2. High pressure mode (2) 3. Pressure mode switch lever

Switch trigger

The pressure washer employs a safety lock on the trigger. To release the trigger lock, depress the lock button into the trigger so the trigger surface becomes flat.

Pull the switch trigger to eject a water jet. The jet continues as long as the trigger is squeezed.

► **Fig.6:** 1. Switch trigger 2. Lock button

Push the lock button back out from inside the trigger to engage the trigger lock.

Be sure to lock the trigger when the pressure washer is not in use.

► **Fig.7:** 1. Switch trigger 2. Lock button

Nozzle functions

Multi-pattern (5-in-1) spray nozzle features a range of spray patterns that you can adjust depending on your washing needs. By combining five of the most-used spray patterns in one nozzle, no more switching from one to the next, simply dial in the right spray pattern for your task.

Simple changeover of nozzles, 0°, 15°, 25°, 40° and shower

► **Fig.8**

► **Fig.9:** 1. Spray pattern symbol 2. Triangle mark

Turn the nozzle head left or right to your desired spray pattern position. Correctly align the spray pattern symbol you want to select with the triangle mark so that the nozzle head locks with a click.

► **Fig.10**

NOTICE: Be careful not to set the nozzle head in an unclicked position. The tool may otherwise create irregular spray patterns resulting in water leaks.

CAUTION: Try not to rotate the nozzle body together as you change spray patterns. The nozzle may come off from the tool body and cause personal injury.

Safety valve

This tool is equipped with a safety valve that prevents undue overpressure.

CAUTION: Do not tamper with or adjust the safety valve setting.

ASSEMBLY

CAUTION: Always be sure that the tool is switched off and the battery cartridge is removed before carrying out any work on the tool.

Installing nozzle and lance extension

CAUTION: Always lock the switch trigger while attaching/detaching a nozzle and extension.

Nozzle

Align the guide projections on the nozzle end with the locking slots in the tool housing. Push the nozzle all the way in until the two triangle marks on the nozzle and housing face to each other. Then turn the nozzle in the direction shown in the figure to engage the lock.

Having installed the nozzle, try pulling it back to ensure it is securely held in place.

► **Fig.11:** 1. Nozzle 2. Guide projection 3. Locking slot 4. Triangle marks 5. Pelvic-fin-like outline

NOTE: Make sure to turn a pelvic-fin-like outline facing downwards.

To detach the nozzle, push and hold the nozzle towards the tool housing, and then turn it counter-wise until the two triangle marks face to each other. Pull the nozzle apart from the tool housing after it becomes unlocked.

Lance extension

Watering any hard-to-reach spots. Install the lance extension in between the tool housing and nozzle by following the same steps as described for nozzle installation.

► **Fig.12:** 1. Lance extension 2. Tool housing 3. Nozzle 4. Guide projections 5. Locking slots 6. Triangle marks

To detach the attachments, push and hold the tip attachment towards the mount attachment/housing, and then turn it counter-wise until the two triangle marks face to each other. Pull the tip attachment apart from the mount attachment/housing after it becomes unlocked.

Connecting to tank water supply

NOTICE: Always use the pressure hose and strainer supplied with this tool to supply water.

NOTICE: Always keep 2.0 m or less in height between the inlet of the pressure washer and the water surface. Otherwise, the pressure washer will be unable to take the water up into the pump.

NOTICE: Be sure to fill a water container more than 25 mm thick from the bottom and to submerge the strainer in water completely.

Water can be supplied from a tank/container/reservoir of any size.

A tank supplied watering addresses such pressure washing situations, e.g., car washing and gardening etc., where water is not available and has to be transported to the washing area or site.

1. Attach the strainer to one end of the pressure hose.

Insert the strainer outlet into the coupling sleeve and push it through until the strainer is secured in place.

► **Fig.13:** 1. Strainer 2. Coupling sleeve 3. Pressure hose

2. Leave the strainer on the bottom of the water container.

► **Fig.14:** 1. Strainer 2. Pressure hose 3. Hose hook

NOTE: Hang the hose along the opening using a supplied hose hook so that the strainer sits still at the bottom of the container.

3. Attach the other end of the hose to the water hose connector on the pressure washer.

Place the coupling sleeve over the inlet of the connector and push it through until the coupling sleeve is secured in place.

► **Fig.15:** 1. Coupling sleeve 2. Water hose connector

CAUTION: Make sure that the pressure hose is securely connected. A loose connection may blow the pressure hose off, resulting in a personal injury.

NOTICE: Introduce water into the pressure washer and hose beforehand whenever you are to lift water from a certain depth in the high pressure mode.

Connecting to mains water supply

CAUTION: Always use the pressure hose supplied with this tool to supply water.

NOTICE: If you connect to the mains for drinking water, use a backflow preventer valve which meets the regulations in your region.

NOTICE: Maintain a feed pressure of the inlet water less than 0.5 MPa for fine feed. Do not exceed the maximum feed pressure as it may cause water leaks when the tool stops working.

Water can be supplied from mains water that is available at the washing area or site.

A continuous water supply allows you not to mind refilling water and enables your efficient home cleaning and gardening, such as spot cleaning, rinsing, and watering on the vast area of lawn or vegetation.

1. Connect the pressure hose to the faucet.

Apply a suitable fitting such as water tap joint to secure the hose end with the faucet.

► **Fig.16:** 1. Water tap joint 2. Coupling sleeve 3. Pressure hose

NOTE: The type of fitting depends on the shape of the faucet to which you connect. Prepare a suitable commercially purchased fitting.

2. Attach the other end of the hose to the water hose connector on the pressure washer.

Place the coupling sleeve over the inlet of the connector and push it through until the coupling sleeve is secured in place.

► **Fig.17:** 1. Coupling sleeve 2. Water hose connector

Installing foam nozzle

Optional accessory

CAUTION: Always lock the switch trigger while attaching/detaching optional attachments.

NOTICE: Use only neutral detergents. Do not use household detergents, acid detergents, alkaline detergents, bleaches, solvents, flammable material, or industrial grade solutions, which may damage the tool or your property. Prepare cleaning solution as instructed on the solution bottle, and always test it in an inconspicuous place in advance.

NOTICE: If a highly viscous detergent is used, the nozzle is likely to clog. When using the high viscosity detergent, dilute the detergent by adding water to the bottle before use.

NOTE: When using the foam nozzle, the detergent in the bottle is diluted with the water supplied by the tool and sprayed. You do not have to dilute the concentration of detergent in the bottle more than necessary. Adjust the concentration of detergent while checking the usage conditions.

NOTE: If the foam nozzle is tipped on its side, the detergent may spill.

Prepare detergent before using the foam nozzle.

1. Fill the tank with detergent. Attach the nozzle onto the tank and securely tighten the lid.

2. Tilt the foam nozzle to align its guide projections with the locking slots in the tool housing. Push the nozzle all the way in and hold it in place. Then turn the foam nozzle in the direction shown in the figure to engage the lock.

► **Fig.18:** 1. Foam nozzle 2. Tank 3. Guide projection 4. Locking slot

Having installed the nozzle, try pulling it back to ensure it is securely held in place.

3. Turn the detergent dial to adjust the suction volume of the detergent solution.

- **Fig.19:** 1. Detergent dial 2. Dial to minimum 3. Dial to maximum

Installing optional nozzles

Optional accessory

CAUTION: Always lock the switch trigger while attaching/detaching optional attachments.

Align the guide projections on an optional nozzle with the locking slots in the tool housing. Push the nozzle all the way in and hold it in place. Then turn the nozzle in the direction shown in the figure to engage the lock. Having installed the nozzle, try pulling it back to ensure it is securely held in place.

- **Fig.20:** 1. Nozzles 2. Guide projection 3. Locking slot

To detach the nozzle, push and hold the nozzle towards the tool housing, and then turn it counter-wise to release the lock. Pull the nozzle apart from the pressure washer after it becomes unlocked.

Installing plastic bottle adapter

Optional accessory

CAUTION: Always lock the switch trigger while attaching/detaching optional attachments.

CAUTION: Be sure to attach the plastic bottle adapter securely to the pressure washer and plastic bottle. Failure to do so may cause the bottle to fall resulting in personal injury.

NOTE: Some kinds of plastic bottles cannot be attached.

(Use the plastic bottle with a screw outer diameter of 28 mm (1-1/8").)

NOTE: A use of 2-liter (half-gallon) plastic bottle can be favored for containing water.

1. Fill water in a plastic bottle.
2. Throw the suction pipe down through the bottle opening.
3. Attach the adapter to the bottle by threading the nut of the coupling sleeve.
4. Attach the plastic bottle adapter to the water hose connector on the pressure washer.

Place the coupling sleeve over the inlet of the connector and push it through until the coupling sleeve is secured in place.

- **Fig.21:** 1. Plastic bottle adapter 2. Suction pipe
3. Plastic bottle 4. Water hose connector

OPERATION

WARNING: Do not touch the water jet or direct it toward yourself or others. The water jet is dangerous and can hurt you or others.

WARNING: When shooting the water jet, never hold the object that you are cleaning or place your hands and feet near the water jet.

CAUTION: Do not run the pressure washer without water for longer than 1 minute(s).

CAUTION: Do not operate the pressure washer for an extended period of time. This may cause overheating or fire. Also, long-term use may cause vibration disorder.

CAUTION: Be aware of the direction of the wind. If the detergent gets into your eyes or mouth, rinse with fresh water immediately and seek medical attention if necessary.

NOTICE: To protect the mechanism of the pressure washer, do not use water hotter than 40°C (104°F).

NOTICE: Do not use an untreated water supply, such as river water, pond water, and sandy or muddy water. Unfiltered dirty water may cause deposition of undesired material in the pump resulting in malfunction.

Water lifting height

A vertical height from the water source to water suction inlet of the pressure washer requires to be within 2.0 m.

Pooled water depth

Fill a water container more than 25 mm thick from the bottom.

- **Fig.22:** 1. Water lifting height 2. Pooled water depth

Steps in basic operation

1. Connect the water hose inlet to the water supply.
2. Connect the water hose outlet to the pressure washer.
► **Fig.23**
3. If the remaining water in the pressure washer has been discharged since it was last used, introduce water into the pressure hose and pressure washer.

Let water run through the hose and washer until any air in them is released.

- (1) Remove the nozzle from the pressure washer.
- (2) Install the battery cartridge into the pressure washer.
- (3) Select the high pressure mode.
- (4) Unlock the switch trigger.
- (5) Pull and hold the switch trigger until the pressure washer generates a stable water jet.

- **Fig.24:** 1. Pressure mode switch lever

After allowing air locks out of the pressure washer and hose, release the switch trigger.

Remove the battery cartridge from the pressure washer, and attach the nozzle suitable for your purpose.

4. Open the cover and install the battery cartridge into the pressure washer and then lock the cover.

► Fig.25: 1. Battery cartridge 2. Cover

CAUTION: Be careful not to pinch your fingers when opening or closing the battery cover.

5. Select your desired pressure mode. Then unlock the switch trigger.

► Fig.26: 1. Pressure mode switch lever 2. Switch trigger 3. Lock button

6. Point the nozzle head at watering area or site. Squeeze the switch trigger.

The water jet continues as long as the trigger is squeezed.

► Fig.27

► Fig.28

CAUTION: Hold the pressure washer firmly. The tool recoils when you pull the switch trigger.

CAUTION: Always hold the pressure washer by the grip and barrel when ejecting water jet.

After use

CAUTION: After operating the pressure washer, always perform the procedure described in this manual. Residual pressure in the pressure washer can cause personal injury or damage to the pump inside.

1. Release the switch trigger and lock it using the lock button.

2. Disconnect the water hose from the water supply.

► Fig.29

3. Unlock the switch trigger and squeeze it until the remaining water in the pressure washer and hose is discharged.

► Fig.30

NOTICE: Do not run the motor for longer than 1 minute(s).

4. Release the switch trigger and lock it using the lock button. Then remove the battery from the pressure washer.

► Fig.31: 1. Lock button 2. Battery cartridge

5. Disconnect the pressure hose from the pressure

washer.

► Fig.32: 1. Coupling sleeve 2. Water hose connector

NOTICE: To prevent the pressure hose from being damaged, remove the remaining water in the hose before storing.

MAINTENANCE

CAUTION: Always be sure that the tool is switched off and battery cartridge is removed before attempting to perform inspection or maintenance.

NOTICE: Never use gasoline, benzine, thinner, alcohol or the like. Discoloration, deformation or cracks may result.

To maintain product SAFETY and RELIABILITY, repairs, any other maintenance or adjustment should be performed by Makita Authorized or Factory Service Centers, always using Makita replacement parts.

Cleaning nozzles

Use the cleaner pin, a tiny file type finger, to remove clogged dirt from the nozzle openings.

► Fig.33: 1. Cleaner pin 2. Nozzle

NOTE: To maintain the optimal performance, clean the nozzle periodically.

NOTICE: Do not remove dirt or debris forcibly. This may result in personal injury or damage to the ejection hole causing deviated jet angles or poor performance.

Cleaning filters

Detach the water hose connector from the pressure washer. Remove dust or dirt adhered to the filter.

► Fig.34: 1. Water hose connector 2. Filter 3. Sealing ring

Disassemble the strainer by unthreading the filter case. Remove dust or dirt adhered to the filter.

► Fig.35: 1. Filter 2. Filter case

NOTE: To maintain the optimal performance, clean the filter periodically.

TROUBLESHOOTING

Before asking for repairs, conduct your own inspection first. If you find a problem that is not explained in the manual, do not attempt to dismantle the tool. Instead, ask Makita Authorized Service Centers, always using Makita replacement parts for repairs.

State of abnormality	Probable cause (malfunction)	Remedy
The washer does not start.	No electricity	Install charged battery cartridge.
	The switch trigger is locked.	Unlock the switch trigger.
	Damaged battery or electric circuit	Contact an authorized service center for repairs.

State of abnormality	Probable cause (malfunction)	Remedy
No water jet / weak water jet	No water supply	Make sure that the faucet is open. If connecting to tank water supply, introduce water into the pressure washer and hose.
	Poor water supply	Turn on the faucet.
	Poor water hose connection	Check the connection between the pressure washer and water supply.
	Deformed or worn water hose	Straighten the hose. Replace the damaged water hose with new one.
	Clogged hose or nozzle	Unclog the hose or nozzle.
	Clogged filters	Remove dust or dirt adhered to the filters in the strainer and the water hose connector.
	Waste/contaminated water	Clean the water system and refill with clean water.
	Damaged or worn nozzle	Replace the nozzle.
	Pump or valve malfunction	Contact an authorized service center for repairs.
	Loose water joint	Secure the connection between water hose and coupling sleeves.
	Leaks from water supply connection	Re-tighten the connection between the water hose and water supply.
	Insufficiently installed strainer	Submerge the strainer into the water completely.
	Low pressure mode in use	Select the high pressure mode.
Unstable water jet	Clogged nozzle	Unclog on the ejection hole of the nozzle using the cleaner pin.
	Poor water suction	Check the water hose for any leakage or clogs.
	The water is too hot.	Supply cooler water.
	Valve malfunction	Contact an authorized service center for repairs.
Abnormal sound	The water is too hot.	Supply cooler water.
Water leakage	Poor connection	Check the connection between the pressure washer and water supply.
	Poor nozzle installation	Push the nozzle all the way in. Then turn the nozzle until it is locked securely.
	Nozzle head stays in an incorrect position	Set the nozzle head in a clicked position with a spray pattern symbol clearly visible.
	Worn out sealings	Contact an authorized service center for repairs.

OPTIONAL ACCESSORIES

CAUTION: These accessories or attachments are recommended for use with your Makita tool specified in this manual. The use of any other accessories or attachments might present a risk of injury to persons. Only use accessory or attachment for its stated purpose.

If you need any assistance for more details regarding these accessories, ask your local Makita Service Center.

NOTE: Some items in the list may be included in the tool package as standard accessories. They may differ from country to country.

Foam nozzle

► Fig.36

Detergent can be sprayed as foam.

Washing brush

► Fig.37

A nozzle equipped with a brush. Useful for washing out dirt while scrubbing with brush.

Angle nozzle

► Fig.38

An angled nozzle head can rotate 360 degrees, allowing for maneuverability and coverage without any dead angles.

Plastic bottle adapter

► Fig.39

Pump bottled water and easily extract it from a plastic bottle. A water bottle can serve as a water source.