

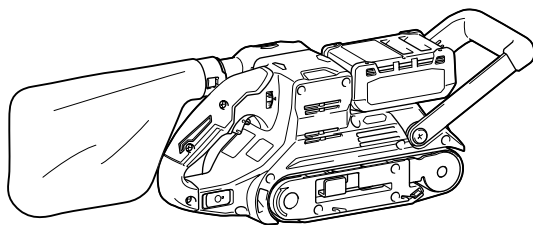

EN	Cordless Belt Sander	INSTRUCTION MANUAL	9
FR	Ponceuse à bande Sans Fil	MANUEL D'INSTRUCTIONS	20
DE	Akku-Bandfeile	BETRIEBSANLEITUNG	32
IT	Lima elettrica a batteria	ISTRUZIONI PER L'USO	45
NL	Accubandschuurmachine	GEBRUIKSAANWIJZING	58
ES	Lijadora de Banda Inalámbrica	MANUAL DE INSTRUCCIONES	70
PT	Lixadeira de Cinta a Bateria	MANUAL DE INSTRUÇÕES	83
EL	Φορητός λειαντήρας ιμάντα	ΕΓΧΕΙΡΙΔΙΟ ΟΔΗΓΙΩΝ	95
TR	Akülü Bant Zımpara Makinası	KULLANMA KILAVUZU	108

BS001G

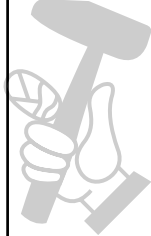

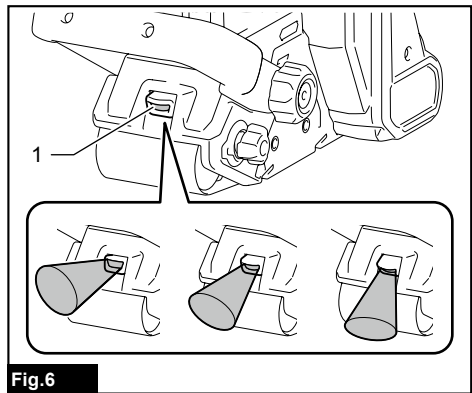
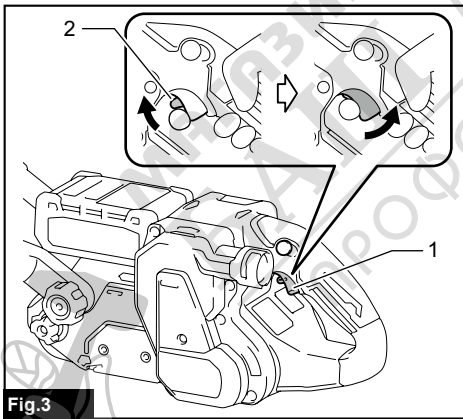
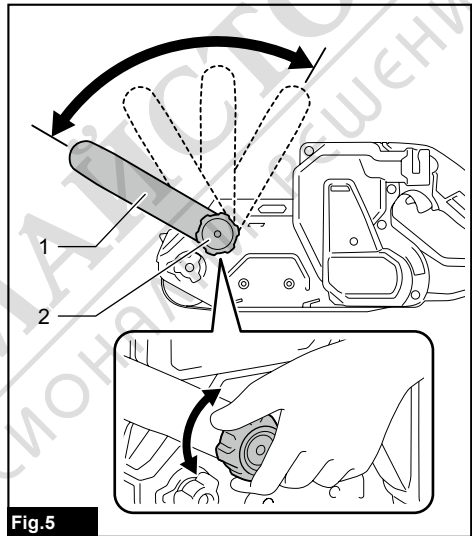
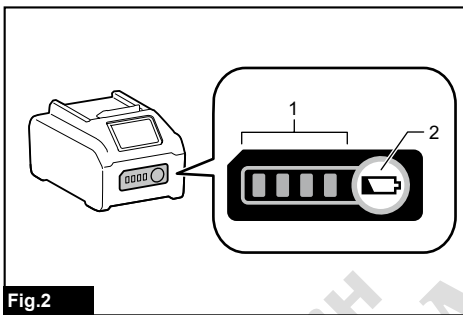
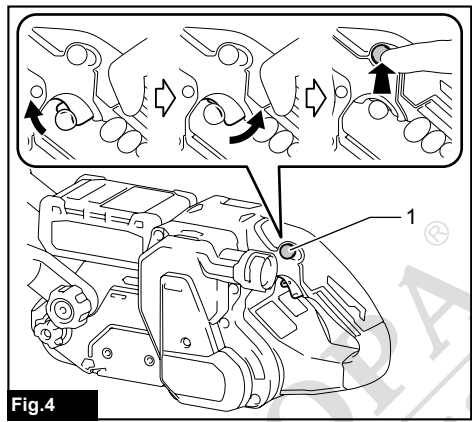
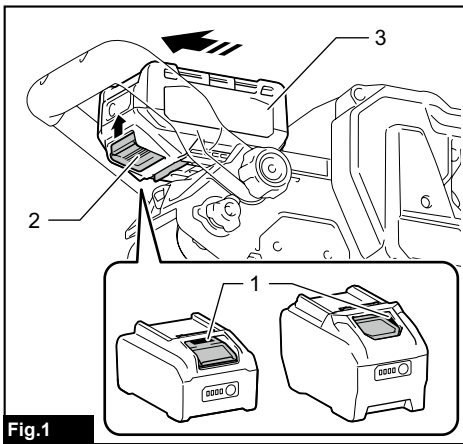

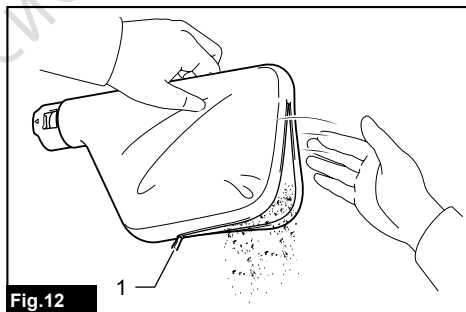
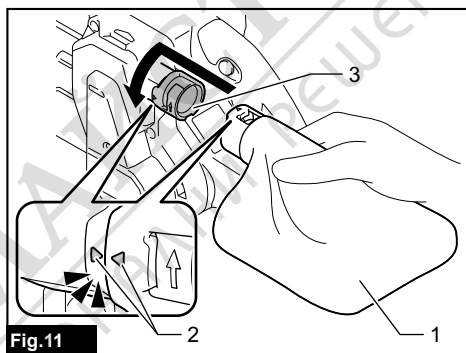
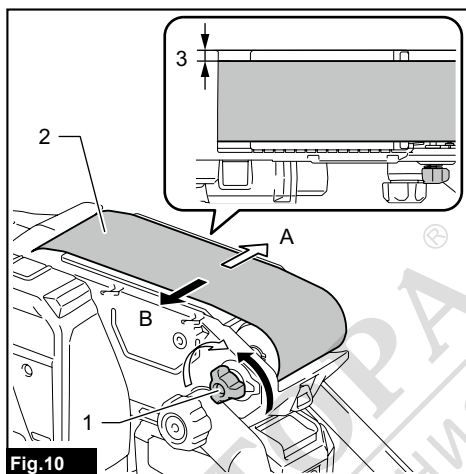
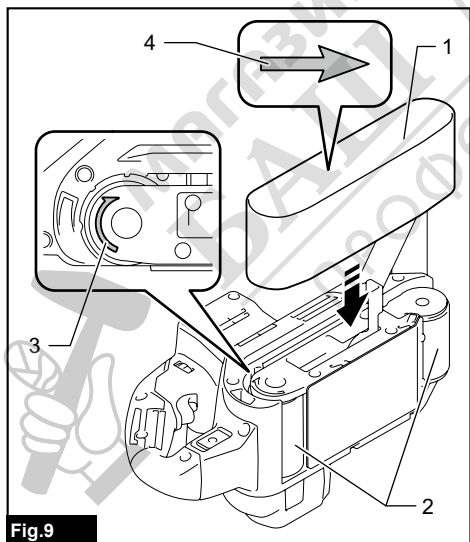
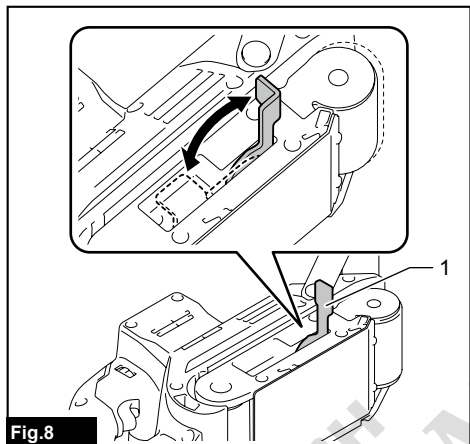
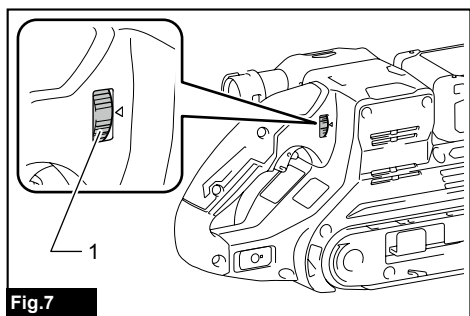

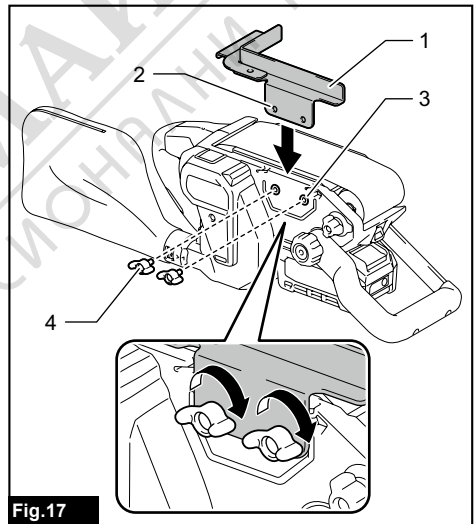
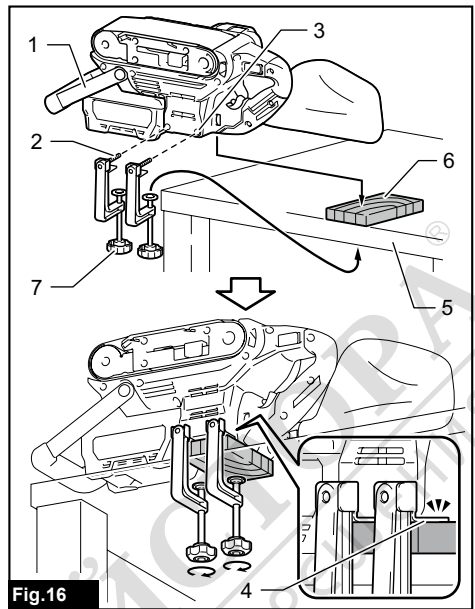
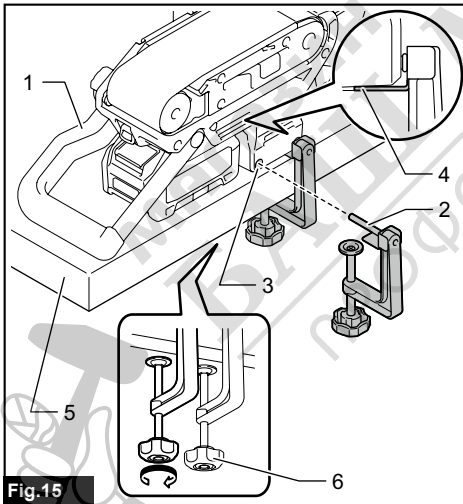
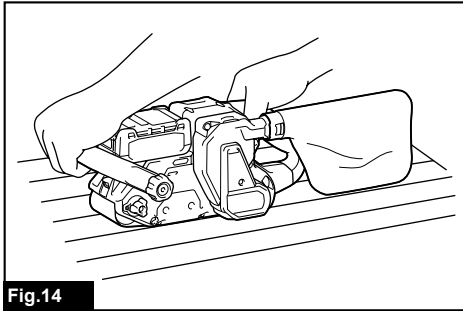
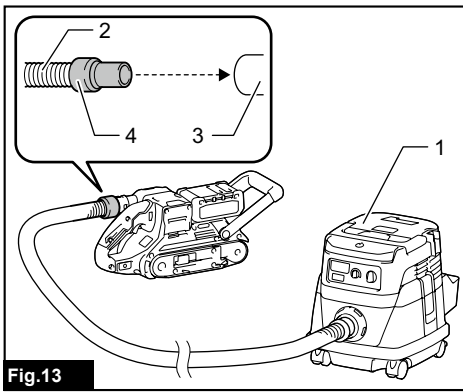

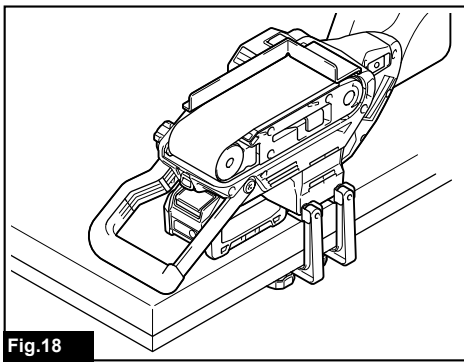

Fig.18

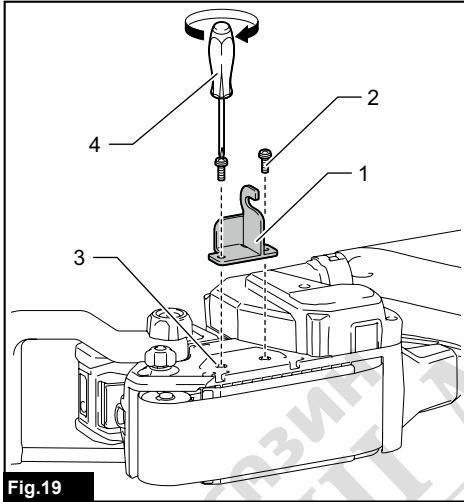

Fig.19

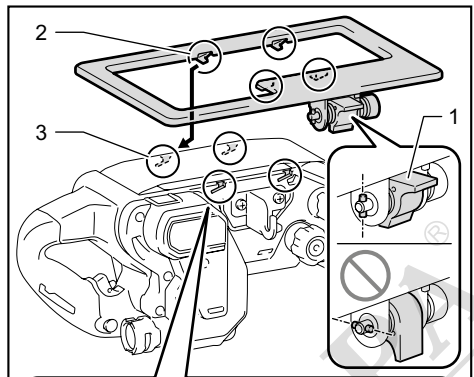

Fig.20

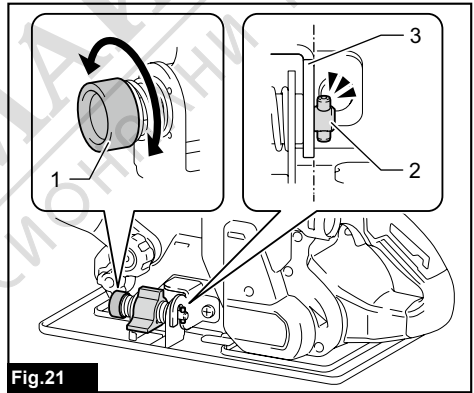
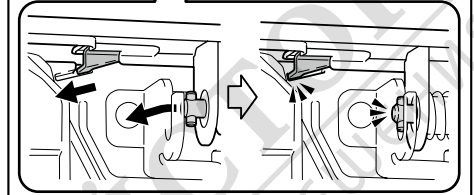

Fig.21



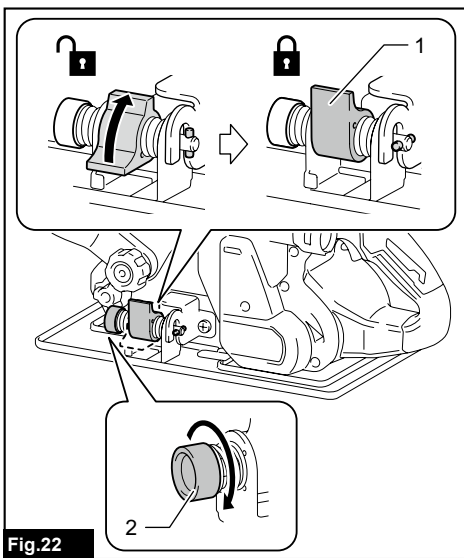

Fig.22

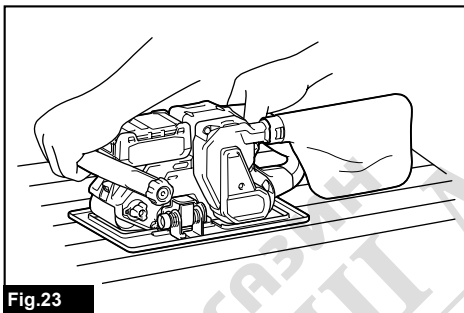

Fig.23

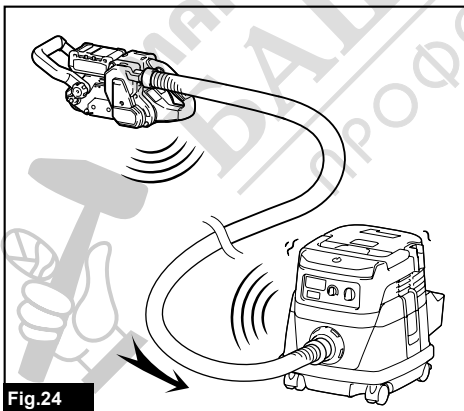

Fig.24

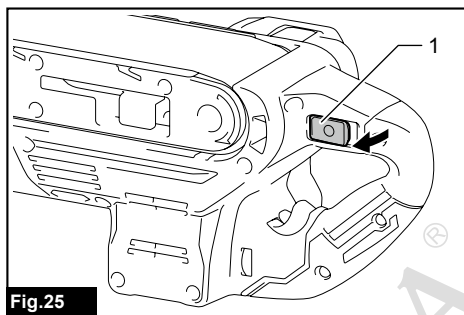

Fig.25

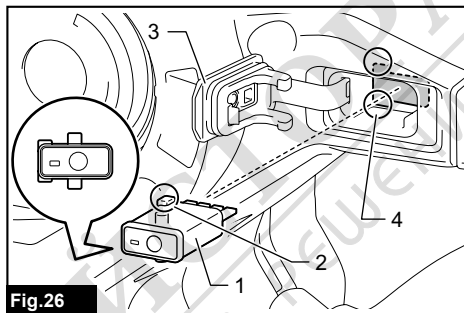

Fig.26

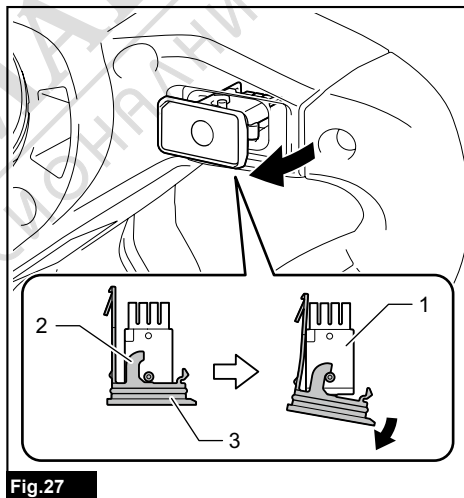
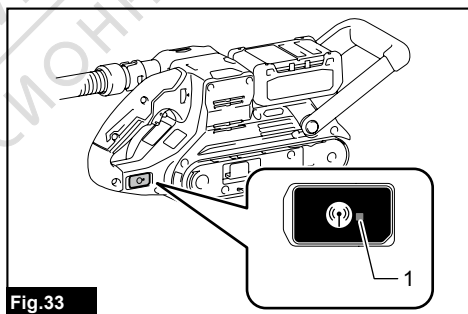
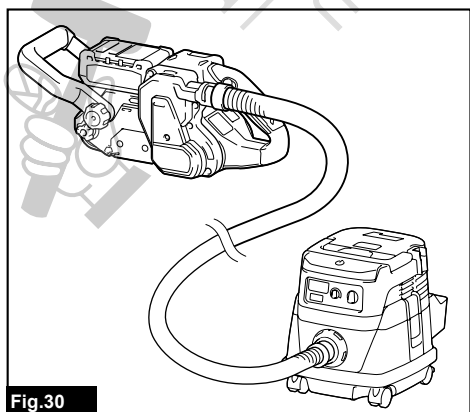
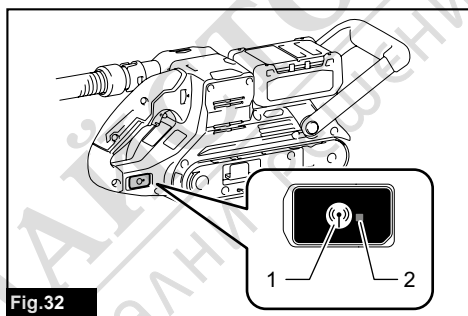
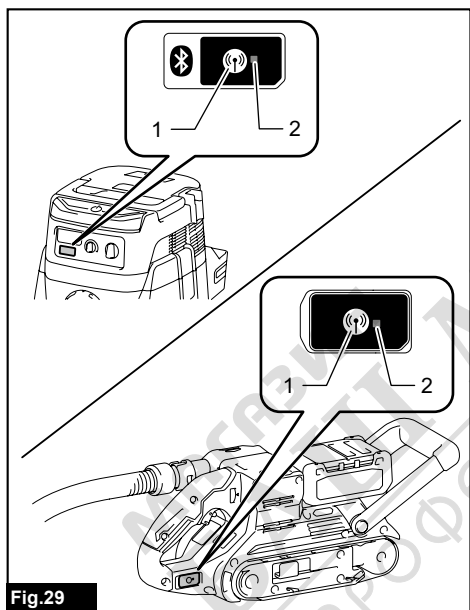
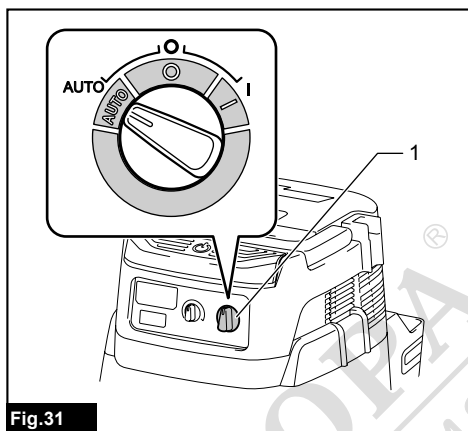
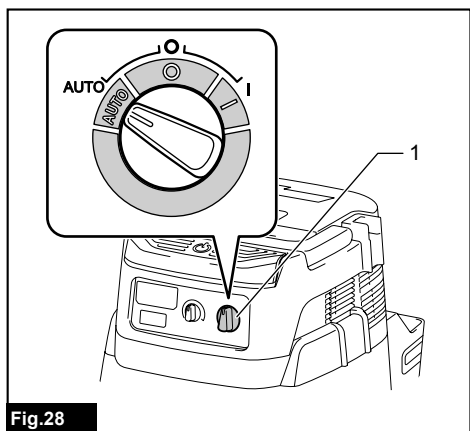

Fig.27



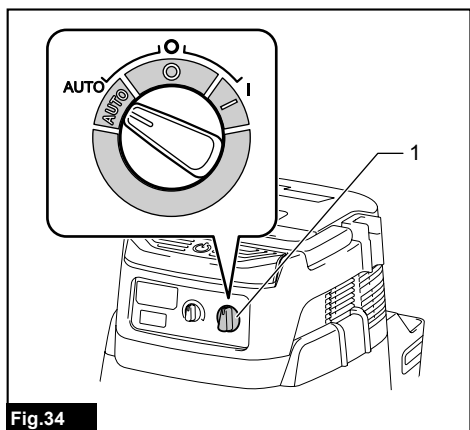

Fig.34

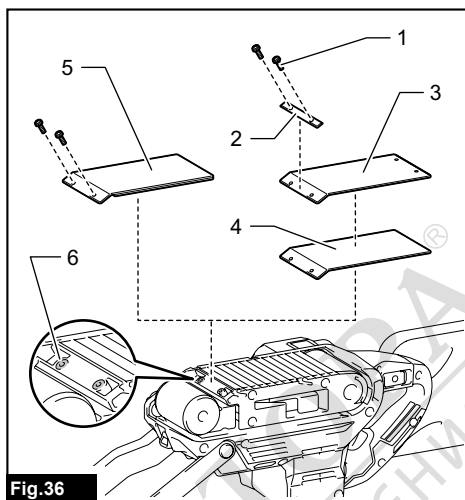

Fig.36

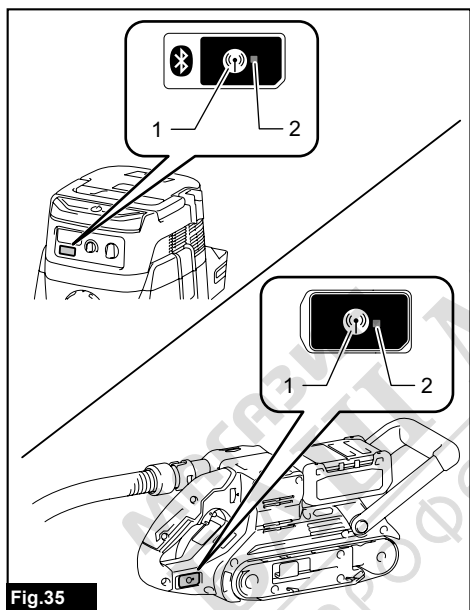

Fig.35

SPECIFICATIONS

Model:	BS001G
Belt size (W x L)	76 mm x 533 mm
Belt speed	120 - 470 m/min
Overall length	440 mm
Rated voltage	D.C. 36 V - 40 V max
Net weight	4.5 - 5.1 kg

- Due to our continuing program of research and development, the specifications herein are subject to change without notice.
- Specifications may differ from country to country.
- The weight may differ depending on the attachment(s), including the battery cartridge. The lightest and heaviest combinations, according to EPTA-Procedure 01/2014, are shown in the table.

Applicable battery cartridge and charger

Battery cartridge	BL4020 / BL4025 / BL4040 / BL4040F / BL4050F
Charger	DC40RA / DC40RB / DC40RC / DC40WA

- Some of the battery cartridges and chargers listed above may not be available depending on your region of residence.

⚠ WARNING: Only use the battery cartridges and chargers listed above. Use of any other battery cartridges and chargers may cause injury and/or fire.

Recommended cord connected power source

Portable power pack	PDC01 / PDC1200 / PDC1500
---------------------	---------------------------

- The cord connected power source(s) listed above may not be available depending on your region of residence.
- Before using the cord connected power source, read instruction and cautionary markings on them.

Symbols

The followings show the symbols which may be used for the equipment. Be sure that you understand their meaning before use.



Read instruction manual.



Wear eye protection.



Do not release the hands from the tool while the sanding belt is rotating. The tool may run by itself.



Ni-MH
Li-ion

Only for EU countries

Due to the presence of hazardous components in the equipment, waste electrical and electronic equipment, accumulators and batteries may have a negative impact on the environment and human health.

Do not dispose of electrical and electronic appliances or batteries with household waste!

In accordance with the European Directive on waste electrical and electronic equipment and on accumulators and batteries and waste accumulators and batteries, as well as their adaptation to national law, waste electrical equipment, batteries and accumulators should be stored separately and delivered to a separate collection point for municipal waste, operating in accordance with the regulations on environmental protection.

This is indicated by the symbol of the crossed-out wheeled bin placed on the equipment.

Intended use

The tool is intended for the sanding of large surface of wood, plastic and metal materials as well as painted surfaces.

Noise

The typical A-weighted noise level determined according to EN62841-2-4:

Sound pressure level ($L_{p(A)}$): 87 dB (A)

Sound power level (L_{WA}): 95 dB (A)

Uncertainty (K): 3 dB (A)

NOTE: The declared noise emission value(s) has been measured in accordance with a standard test method and may be used for comparing one tool with another.

NOTE: The declared noise emission value(s) may also be used in a preliminary assessment of exposure.

⚠ WARNING: Wear ear protection.

⚠ WARNING: The noise emission during actual use of the power tool can differ from the declared value(s) depending on the ways in which the tool is used especially what kind of workpiece is processed.

⚠ WARNING: Be sure to identify safety measures to protect the operator that are based on an estimation of exposure in the actual conditions of use (taking account of all parts of the operating cycle such as the times when the tool is switched off and when it is running idle in addition to the trigger time).

Vibration

The vibration total value (tri-axial vector sum) determined according to EN62841-2-4:

Work mode: sanding metal plate

Vibration emission (a_{h1}): 2.5 m/s² or less

Uncertainty (K): 1.5 m/s²

NOTE: The declared vibration total value(s) has been measured in accordance with a standard test method and may be used for comparing one tool with another.

NOTE: The declared vibration total value(s) may also be used in a preliminary assessment of exposure.

⚠ WARNING: The vibration emission during actual use of the power tool can differ from the declared value(s) depending on the ways in which the tool is used especially what kind of workpiece is processed.

⚠ WARNING: Be sure to identify safety measures to protect the operator that are based on an estimation of exposure in the actual conditions of use (taking account of all parts of the operating cycle such as the times when the tool is switched off and when it is running idle in addition to the trigger time).

Declarations of Conformity

For European countries only

The Declarations of conformity are included in Annex A to this instruction manual.

SAFETY WARNINGS

General power tool safety warnings

⚠ WARNING Read all safety warnings, instructions, illustrations and specifications provided with this power tool. Failure to follow all instructions listed below may result in electric shock, fire and/or serious injury. 

Save all warnings and instructions for future reference.

The term "power tool" in the warnings refers to your mains-operated (corded) power tool or battery-operated (cordless) power tool.

CORDLESS BELT SANDER SAFETY WARNINGS

1. Ventilate your work area adequately when you perform sanding operations.
2. Some material contains chemicals which may be toxic. Take caution to prevent dust inhalation and skin contact. Follow material supplier safety data.
3. Always use the correct dust mask/respirator for the material and application you are working with.
4. Always use safety glasses or goggles. Ordinary eye or sun glasses are NOT safety glasses.
5. Hold the tool firmly with both hands.
6. Make sure the belt is not contacting the workpiece before the switch is turned on.
7. Keep hands and face away from the rotating parts.
8. Do not leave the tool running. Operate the tool only when hand-held.
9. This tool has not been waterproofed, so do not use water on the workpiece surface.

SAVE THESE INSTRUCTIONS.

⚠ WARNING: DO NOT let comfort or familiarity with product (gained from repeated use) replace strict adherence to safety rules for the subject product. MISUSE or failure to follow the safety rules stated in this instruction manual may cause serious personal injury.

Important safety instructions for battery cartridge

1. Before using battery cartridge, read all instructions and cautionary markings on (1) battery charger, (2) battery, and (3) product using battery.
2. Do not disassemble or tamper with the battery cartridge. It may result in a fire, excessive heat, or explosion.
3. If operating time has become excessively shorter, stop operating immediately. It may result in a risk of overheating, possible burns

and even an explosion.

4. If electrolyte gets into your eyes, rinse them out with clear water and seek medical attention right away. It may result in loss of your eyesight.
5. Do not short the battery cartridge:
 - (1) Do not touch the terminals with any conductive material.
 - (2) Avoid storing battery cartridge in a container with other metal objects such as nails, coins, etc.
 - (3) Do not expose battery cartridge to water or rain.
6. Do not store and use the tool and battery cartridge in locations where the temperature may reach or exceed 50 °C (122 °F).
7. Do not incinerate the battery cartridge even if it is severely damaged or is completely worn out. The battery cartridge can explode in a fire.
8. Do not nail, cut, crush, throw, drop the battery cartridge, or hit against a hard object to the battery cartridge. Such conduct may result in a fire, excessive heat, or explosion.
9. Do not use a damaged battery.
10. The contained lithium-ion batteries are subject to the Dangerous Goods Legislation requirements.

For commercial transports e.g. by third parties, forwarding agents, special requirement on packaging and labeling must be observed.

For preparation of the item being shipped, consulting an expert for hazardous material is required. Please also observe possibly more detailed national regulations.

Tape or mask off open contacts and pack up the battery in such a manner that it cannot move around in the packaging.

11. When disposing the battery cartridge, remove it from the tool and dispose of it in a safe place. Follow your local regulations relating to disposal of battery.
12. Use the batteries only with the products specified by Makita. Installing the batteries to non-compliant products may result in a fire, excessive heat, explosion, or leak of electrolyte.
13. If the tool is not used for a long period of time, the battery must be removed from the tool.
14. During and after use, the battery cartridge may take on heat which can cause burns or low temperature burns. Pay attention to the handling of hot battery cartridges.
15. Do not touch the terminal of the tool immediately after use as it may get hot enough to cause burns.
16. Do not allow chips, dust, or soil stuck into the terminals, holes, and grooves of the battery cartridge. It may cause heating, catching fire, burst and malfunction of the tool or battery cartridge, resulting in burns or personal injury.
17. Unless the tool supports the use near high-voltage electrical power lines, do not use

the battery cartridge near high-voltage electrical power lines. It may result in a malfunction or breakdown of the tool or battery cartridge.

18. Keep the battery away from children.

SAVE THESE INSTRUCTIONS.

CAUTION: Only use genuine Makita batteries. Use of non-genuine Makita batteries, or batteries that have been altered, may result in the battery bursting causing fires, personal injury and damage. It will also void the Makita warranty for the Makita tool and charger.

Tips for maintaining maximum battery life

1. Charge the battery cartridge before completely discharged. Always stop tool operation and charge the battery cartridge when you notice less tool power.
2. Never recharge a fully charged battery cartridge. Overcharging shortens the battery service life.
3. Charge the battery cartridge with room temperature at 10 °C - 40 °C (50 °F - 104 °F). Let a hot battery cartridge cool down before charging it.
4. When not using the battery cartridge, remove it from the tool or the charger.
5. Charge the battery cartridge if you do not use it for a long period (more than six months).

Important safety instructions for wireless unit

1. Do not disassemble or tamper with the wireless unit.
2. Keep the wireless unit away from young children. If accidentally swallowed, seek medical attention immediately.
3. Use the wireless unit only with Makita tools.
4. Do not expose the wireless unit to rain or wet conditions.
5. Do not use the wireless unit in places where the temperature exceeds 50 °C (122 °F).
6. Do not operate the wireless unit in places where medical instruments, such as heart pace makers are nearby.
7. Do not operate the wireless unit in places where automated devices are nearby. If operated, automated devices may develop malfunction or error.
8. Do not operate the wireless unit in places under high temperature or places where static electricity or electrical noise could be generated.
9. The wireless unit can produce electromagnetic fields (EMF) but they are not harmful to the user.
10. The wireless unit is an accurate instrument. Be careful not to drop or strike the wireless unit.
11. Avoid touching the terminal of the wireless unit with bare hands or metallic materials.

12. Always remove the battery on the product when installing the wireless unit into it.
13. When opening the lid of the slot, avoid the place where dust and water may come into the slot. Always keep the inlet of the slot clean.
14. Always insert the wireless unit in the correct direction.
15. Do not press the wireless activation button on the wireless unit too hard and/or press the button with an object with a sharp edge.
16. Always close the lid of the slot when operating.
17. Do not remove the wireless unit from the slot while the power is being supplied to the tool. Doing so may cause a malfunction of the wireless unit.
18. Do not remove the sticker on the wireless unit.
19. Do not put any sticker on the wireless unit.
20. Do not leave the wireless unit in a place where static electricity or electrical noise could be generated.
21. Do not leave the wireless unit in a place subject to high heat, such as a car sitting in the sun.
22. Do not leave the wireless unit in a dusty or powdery place or in a place corrosive gas could be generated.
23. Sudden change of the temperature may bedew the wireless unit. Do not use the wireless unit until the dew is completely dried.
24. When cleaning the wireless unit, gently wipe with a dry soft cloth. Do not use benzine, thinner, conductive grease or the like.
25. When storing the wireless unit, keep it in the supplied case or a static-free container.
26. Do not insert any devices other than Makita wireless unit into the slot on the tool.
27. Do not use the tool with the lid of the slot damaged. Water, dust, and dirt come into the slot may cause malfunction.
28. Do not pull and/or twist the lid of the slot more than necessary. Restore the lid if it comes off from the tool.
29. Replace the lid of the slot if it is lost or damaged.

SAVE THESE INSTRUCTIONS.



FUNCTIONAL DESCRIPTION

CAUTION: Always be sure that the tool is switched off and the battery cartridge is removed before adjusting or checking function on the tool.

Installing or removing battery cartridge

CAUTION: Always switch off the tool before installing or removing of the battery cartridge.

CAUTION: Hold the tool and the battery cartridge firmly when installing or removing battery cartridge. Failure to hold the tool and the battery cartridge firmly may cause them to slip off your hands and result in damage to the tool and battery cartridge and a personal injury.

To install the battery cartridge, align the tongue on the battery cartridge with the groove in the housing and slip it into place. Insert it all the way until it locks in place with a little click. If you can see the red indicator as shown in the figure, it is not locked completely.

To remove the battery cartridge, slide it from the tool while sliding the button on the front of the cartridge.

► Fig.1: 1. Red indicator 2. Button 3. Battery cartridge

CAUTION: Always install the battery cartridge fully until the red indicator cannot be seen. If not, it may accidentally fall out of the tool, causing injury to you or someone around you.

CAUTION: Do not install the battery cartridge forcibly. If the cartridge does not slide in easily, it is not being inserted correctly.

Tool / battery protection system

The tool is equipped with a tool/battery protection system. This system automatically cuts off power to the motor to extend tool and battery life. The tool will automatically stop during operation if the tool or battery is placed under one of the following conditions:

Overload protection

When the tool or battery is operated in a manner that causes it to draw an abnormally high current, the tool automatically stops without any indication. In this situation, turn the tool off and stop the application that caused the tool to become overloaded. Then turn the tool on to restart.

Overheat protection

When the tool or battery is overheated, the tool stops automatically. In this case, let the tool and battery cool before turning the tool on again.

Overdischarge protection

When the battery capacity is not enough, the tool stops automatically. In this case, remove the battery from the tool and charge the battery.

Protections against other causes

Protection system is also designed for other causes that could damage the tool and allows the tool to stop automatically. Take all the following steps to clear the causes, when the tool has been brought to a temporary halt or stop in operation.

1. Make sure that all switch(es) is/are in the off position, and then turn the tool on again to restart.
2. Charge the battery(ies) or replace it/them with recharged battery(ies).
3. Let the tool and battery(ies) cool down.

If no improvement can be found by restoring protection system, then contact your local Makita Service Center.

Indicating the remaining battery capacity

Press the check button on the battery cartridge to indicate the remaining battery capacity. The indicator lamps light up for a few seconds.

► **Fig.2:** 1. Indicator lamps 2. Check button

Indicator lamps			Remaining capacity
Lighted	Off	Blinking	
			75% to 100%
			50% to 75%
			25% to 50%
			0% to 25%
			Charge the battery.
			The battery may have malfunctioned.

NOTE: Depending on the conditions of use and the ambient temperature, the indication may differ slightly from the actual capacity.

NOTE: The first (far left) indicator lamp will blink when the battery protection system works.

Switch action

WARNING: For your safety, this tool is equipped with the lock-off lever which prevents the tool from unintended starting. NEVER use the tool if it runs when you simply pull the switch trigger without releasing the lock-off lever. Return the tool to our authorized service center for proper repairs BEFORE further usage.

CAUTION: Before installing the battery cartridge into the tool, always check to see that the switch trigger actuates properly and returns to the "OFF" position when released. Operating a tool with a switch that does not actuate properly can lead to loss of control and serious personal injury.

NOTICE: Do not pull the switch trigger hard without releasing the lock-off lever. This can cause switch breakage.

To prevent the switch trigger from being accidentally pulled, a lock-off lever is provided. The switch trigger is locked when the lock-off lever is in the original position and unlocked when the lock-off lever is pushed upward.

To start the tool, pull the switch trigger while pushing the lock-off lever upward. Release the switch trigger to stop.

► **Fig.3:** 1. Switch trigger 2. Lock-off lever

For continuous operation, pull the switch trigger while pushing the lock-off lever upward and then push in the lock-on button. After that, release the switch trigger with the lock-on button pushed in.

To stop the tool from the locked switch position, pull the switch trigger fully, and then release it.

► **Fig.4:** 1. Lock-on button

Front handle

The angle of the front handle can be adjusted in 4 steps of 30°.

To adjust the angle of the front handle to a comfortable working angle, loosen the clamping knob. Set the angle of the front handle and tighten the clamping knob.

► **Fig.5:** 1. Front handle 2. Clamping knob

Lighting up the front lamp

CAUTION: Do not look in the light or see the source of light directly.

The lighting direction can be adjusted in three levels. Pull the switch trigger to turn on the front lamp. To turn off, release it. The front lamp goes out approximately 10 seconds after releasing the switch trigger.

► **Fig.6:** 1. Front lamp

NOTE: When the tool is overheated, the light flashes for one minute. In this case, cool down the tool before operating again.

NOTE: Use a dry cloth to wipe the dirt off the lens of the lamp. Be careful not to scratch the lens of the lamp, or it may lower the illumination.

Speed adjusting dial

CAUTION: Do not operate the tool continuously at low speeds for a long time. Otherwise the motor will get overloaded, resulting in tool malfunction.

CAUTION: The speed adjusting dial can be turned only as far as 5 and back to 1. Do not force it past 5 or 1, or the speed adjusting function may no longer work.

The belt speed can be adjusted between 120 m and 470 m per minute by turning the speed adjusting dial to a given number setting from 1 to 5.

Higher speed is obtained when the dial is turned in the direction of number 5; lower speed is obtained when it is turned in the direction of number 1. Select the proper speed for the workpiece to be sanded.

► **Fig.7:** 1. Speed adjusting dial

Constant speed control

Electronic speed control for obtaining constant speed. This feature enables the fine finish because the tool speed remains constant even under load.

Accidental re-start preventive function

Even if you install the battery cartridge while pulling the switch trigger, the tool does not start.

To start the tool, first release the switch trigger and then pull the switch trigger.

ASSEMBLY

CAUTION: Always be sure that the tool is switched off and the battery cartridge is removed before carrying out any work on the tool.

Installing or removing sanding belt

Installing sanding belt

CAUTION: When installing the sanding belt, make sure that the direction of the arrow on the back of the sanding belt corresponds to the one on the tool.

1. Pull the lever all the way out.

► **Fig.8:** 1. Lever

2. Install the sanding belt to the rollers so that the direction of the arrow on the back of the sanding belt matches the direction of the arrow on the tool, then return the lever to its original position.

► **Fig.9:** 1. Sanding belt 2. Roller 3. Arrow (on the tool) 4. Arrow (on the back of the sanding belt)

Removing sanding belt

1. Pull the lever all the way out.

2. Remove the sanding belt from the rollers, then return the lever to its original position.

Adjusting sanding belt tracking

Adjusting the sanding belt tracking can extend the life of the sanding belt.

Turning the adjusting knob clockwise moves the sanding belt to side A as shown in the figure.

Turning the adjusting knob counterclockwise moves the sanding belt to side B as shown in the figure.

1. Install the battery cartridge to the tool.
2. While rotating the sanding belt, turn the adjusting knob to make an approximately 0 - 3 mm gap between the side of the sanding belt and the side of the tool as shown in the figure.

► **Fig.10:** 1. Adjusting knob 2. Sanding belt 3. Approximately 0 - 3 mm

Installing or removing dust bag

CAUTION: Before sanding steel plate, always empty the dust bag if dust from wood or other material is contained in it. Dust from wood or other material may cause fire.

The tool can collect dust from the sanding into the dust bag when the dust bag is installed to the tool.

To install the dust bag, align the triangle mark on the dust bag with the guide on the dust nozzle. Push the dust bag into the dust nozzle and then turn it counterclockwise until the triangle marks point each other as shown in the figure.

To remove the dust bag, follow the installation procedures in reverse.

► **Fig.11:** 1. Dust bag 2. Triangle mark 3. Dust nozzle

Disposing of dust

When the dust bag is about half full, remove the dust bag from the tool and open the dust bag fastener.

Dispose of the dust by tapping the dust bag lightly to remove particles stuck inside.

► **Fig.12:** 1. Dust bag fastener

NOTE: If you connect a Makita vacuum cleaner to this tool, more efficient and cleaner operations can be performed.

Connecting with vacuum cleaner

Optional accessory

CAUTION: Connect the tool to the vacuum cleaner when sanding the drywall.

Cleaner sanding operations can be performed by connecting the belt sander to Makita vacuum cleaner.

Connect a hose of the Makita vacuum cleaner to the dust nozzle of the tool using the front cuff 22.

► **Fig.13:** 1. Vacuum cleaner 2. Hose of the vacuum cleaner 3. Dust nozzle 4. Front cuff 22

NOTE: The front cuff 22 is the optional accessories or supplied with the vacuum cleaner.

OPERATION

CAUTION: Secure workpiece with clamps, etc. if it possibly moves during operation.

CAUTION: Avoid any sanding operations on ignitable materials such as aluminum and magnesium. It may result in a fire, explosion or risk of injury.

CAUTION: Be sure that not any part of the sanding belt is placed on the surface of workpiece before you turn the tool on or off. Otherwise a poor sanding finish, damage to the belt or loss of control of the tool may result.

CAUTION: Avoid body contact with the sanding belt and rotating parts of the tool during operation. Always be aware of your surroundings and bystanders, and stay alert for possible hazards.

CAUTION: Do not sand steel plates under heavy load for long periods of time. Otherwise the dust bag may be damaged by hot dust.

CAUTION: Make sure that sparks do not hit objects or people when sanding the steel plate. Otherwise sparks may cause fire or burns.

CAUTION: Do not release the hands from the tool while the sanding belt is rotating. Otherwise the tool may run by itself and cause injury.

Hold the tool firmly with both hands. Turn the tool on and wait until it attains full speed. Then gently place the tool on the workpiece surface. Keep the sanding belt flush with the workpiece at all times and move the tool back and forth.

Never force the tool. The weight of the tool applies adequate pressure. Excessive pressure may cause the motor to stall, overheat, burn out the workpiece, and kickback.

► Fig.14

Operation with clamp and guide rule

Optional accessory

The use of the guide rule installed to the tool enables stable sanding of the workpiece.

Installing or removing clamp and guide rule

CAUTION: Place an appropriate spacer between the tool and the workbench when working with battery cartridges as shown in the table below. Otherwise the tool will become unstable and cause injury.

Refer to the table and prepare the appropriate spacer if a spacer is required.

The battery cartridges in the table below are part of the examples. Use the appropriate spacer to fill the gap between the tool and the workbench.

Examples of battery cartridge	BL4050F
Spacer height	23 mm

1. Set the front handle to the lowest position and place the tool upside down as shown in the figure.
2. Insert the rod part of the clamp into the hole on the tool so that the plate part of the clamp is between the tool and the workbench or the spacer. Then tighten the clamping knob.

— **When spacer is not used**

- Fig.15: 1. Front handle 2. Rod part 3. Hole 4. Plate part 5. Workbench 6. Clamping knob

— **When spacer is used**

- Fig.16: 1. Front handle 2. Rod part 3. Hole 4. Plate part 5. Workbench 6. Spacer 7. Clamping knob

3. Align the holes on the guide rule with the screw holes on the tool and secure the guide rule with the butterfly screws.

- Fig.17: 1. Guide rule 2. Hole 3. Screw hole 4. Butterfly screw

To remove the guide rule, follow the installation procedures in reverse.

Operation with clamp and guide rule

Turn on the tool and let it run continuously. Wait until the sanding belt attains full speed, then sand by pressing the workpiece against the sanding belt while holding the workpiece firmly.

Never force the workpiece. Excessive pressure may cause the motor to stall, overheat, burn out the workpiece, and kickback.

► Fig.18

Operation with sanding shoe

Optional accessory

The sanding shoe readily allows you to sand workpieces more evenly.

Installing or removing sanding shoe

1. Align the holes on the slide plate with the screw holes on the tool and secure the slide plate with the screws.

- Fig.19: 1. Slide plate 2. Screw 3. Screw hole 4. Phillips screwdriver

2. Set the lock lever to the free position as shown in the figure and insert the four protrusions of the base into the four grooves of the tool.

- Fig.20: 1. Lock lever 2. Protrusion 3. Groove

3. Turn the knob of the sanding shoe to adjust the position of the locking pin so that the locking pin goes through the slide plate as shown in the figure.

- Fig.21: 1. Knob 2. Locking pin 3. Slide plate

4. Turn the lock lever in the direction of the arrow as shown in the figure.

- Fig.22: 1. Lock lever 2. Knob

5. Turn the knob clockwise to fix the sanding shoe to the tool.

6. Make sure that the sanding shoe does not wobble. If the sanding shoe wobbles, turn the knob again.

To remove the sanding shoe, follow the installation procedures in reverse.

Operation with sanding shoe

Hold the tool firmly with both hands. Turn the tool on and wait until it attains full speed. Then gently place the tool on the workpiece surface. Keep the sanding belt flush with the workpiece at all times and move the tool back and forth.

Never force the tool. The weight of the tool applies adequate pressure. Excessive pressure may cause the motor to stall, overheat, burn out the workpiece, and kickback.

► Fig.23

WIRELESS ACTIVATION FUNCTION

Optional accessory

What you can do with the wireless activation function

The wireless activation function enables clean and comfortable operation. By connecting a supported vacuum cleaner to the tool, you can run the vacuum cleaner automatically along with the switch operation of the tool.

► Fig.24

To use the wireless activation function, prepare following items:

- A wireless unit (optional accessory)
- A vacuum cleaner which supports the wireless activation function

The overview of the wireless activation function setting is as follows. Refer to each section for detail procedures.

1. Installing the wireless unit
2. Tool registration for the vacuum cleaner
3. Starting the wireless activation function

Installing the wireless unit

Optional accessory

CAUTION: Place the tool on a flat and stable surface when installing the wireless unit.

NOTICE: Clean the dust and dirt on the tool before installing the wireless unit. Dust or dirt may cause malfunction if it comes into the slot of the wireless unit.

NOTICE: To prevent the malfunction caused by static, touch a static discharging material, such as a metal part of the tool, before picking up the wireless unit.

NOTICE: When installing the wireless unit, always be sure that the wireless unit is inserted in the correct direction and the lid is completely closed.

1. Open the lid on the tool as shown in the figure.

► Fig.25: 1. Lid

2. Insert the wireless unit to the slot and then close the lid.

When inserting the wireless unit, align the projections with the recessed portions on the slot.

► Fig.26: 1. Wireless unit 2. Projection 3. Lid
4. Recessed portion

When removing the wireless unit, open the lid slowly. The hooks on the back of the lid will lift the wireless unit as you pull up the lid.

► Fig.27: 1. Wireless unit 2. Hook 3. Lid

After removing the wireless unit, keep it in the supplied case or a static-free container.

NOTICE: Always use the hooks on the back of the lid when removing the wireless unit. If the hooks do not catch the wireless unit, close the lid completely and open it slowly again.

Tool registration for the vacuum cleaner

NOTE: A Makita vacuum cleaner supporting the wireless activation function is required for the tool registration.

NOTE: Finish installing the wireless unit to the tool before starting the tool registration.

NOTE: During the tool registration, do not pull the switch trigger or turn on the power switch on the vacuum cleaner.

NOTE: Refer to the instruction manual of the vacuum cleaner, too.

If you wish to activate the vacuum cleaner along with the switch operation of the tool, finish the tool registration beforehand.

1. Install the batteries to the vacuum cleaner and the tool.
2. Set the stand-by switch on the vacuum cleaner to "AUTO".

► Fig.28: 1. Stand-by switch

3. Press the wireless activation button on the vacuum cleaner for 3 seconds until the wireless activation lamp blinks in green. And then press the wireless activation button on the tool in the same way.

► Fig.29: 1. Wireless activation button 2. Wireless activation lamp

If the vacuum cleaner and the tool are linked successfully, the wireless activation lamps will light up in green for 2 seconds and start blinking in blue.

NOTE: The wireless activation lamps finish blinking in green after 20 seconds elapsed. Press the wireless activation button on the tool while the wireless activation lamp on the cleaner is blinking. If the wireless activation lamp does not blink in green, push the wireless activation button briefly and hold it down again.

NOTE: When performing two or more tool registrations for one vacuum cleaner, finish the tool registration one by one.

Starting the wireless activation function

NOTE: Finish the tool registration for the vacuum cleaner prior to the wireless activation.

NOTE: Refer to the instruction manual of the vacuum cleaner, too.

After registering a tool to the vacuum cleaner, the vacuum cleaner will automatically run along with the switch operation of the tool.

1. Install the wireless unit to the tool.
2. Connect the hose of the vacuum cleaner with the tool.
► **Fig.30**

3. Set the stand-by switch on the vacuum cleaner to "AUTO".

► **Fig.31:** 1. Stand-by switch

4. Push the wireless activation button on the tool briefly. The wireless activation lamp will blink in blue.

► **Fig.32:** 1. Wireless activation button 2. Wireless activation lamp

5. Turn on the tool. Check if the vacuum cleaner runs while the tool is operating.

To stop the wireless activation of the vacuum cleaner, push the wireless activation button on the tool.

NOTE: The wireless activation lamp on the tool will stop blinking in blue when there is no operation for 2 hours. In this case, set the stand-by switch on the vacuum cleaner to "AUTO" and push the wireless activation button on the tool again.

NOTE: The vacuum cleaner starts/stops with a delay. There is a time lag when the vacuum cleaner detects a switch operation of the tool.

NOTE: The transmission distance of the wireless unit may vary depending on the location and surrounding circumstances.

NOTE: When two or more tools are registered to one vacuum cleaner, the vacuum cleaner may start running even if you do not turn on your tool because another user is using the wireless activation function.

Description of the wireless activation lamp status

► **Fig.33:** 1. Wireless activation lamp

The wireless activation lamp shows the status of the wireless activation function. Refer to the table below for the meaning of the lamp status.

Status	Wireless activation lamp			Duration	Description
	Color	<input type="checkbox"/> On	<input checked="" type="checkbox"/> Blinking		
Standby	Blue	<input checked="" type="checkbox"/>		2 hours	The wireless activation of the vacuum cleaner is available. The lamp will automatically turn off when no operation is performed for 2 hours.
		<input type="checkbox"/>		When the tool is running.	The wireless activation of the vacuum cleaner is available and the tool is running.
Tool registration	Green	<input checked="" type="checkbox"/>		20 seconds	Ready for the tool registration. Waiting for the registration by the vacuum cleaner.
		<input type="checkbox"/>		2 seconds	The tool registration has been finished. The wireless activation lamp will start blinking in blue.
Cancelling tool registration	Red	<input checked="" type="checkbox"/>		20 seconds	Ready for the cancellation of the tool registration. Waiting for the cancellation by the vacuum cleaner.
		<input type="checkbox"/>		2 seconds	The cancellation of the tool registration has been finished. The wireless activation lamp will start blinking in blue.
Others	Red	<input type="checkbox"/>		3 seconds	The power is supplied to the wireless unit and the wireless activation function is starting up.
		-	-	-	The wireless activation of the vacuum cleaner is stopped.

Cancelling tool registration for the vacuum cleaner

Perform the following procedure when cancelling the tool registration for the vacuum cleaner.

1. Install the batteries to the vacuum cleaner and the tool.

2. Set the stand-by switch on the vacuum cleaner to "AUTO".

► **Fig.34:** 1. Stand-by switch

3. Press the wireless activation button on the vacuum cleaner for 6 seconds. The wireless activation lamp blinks in green and then become red. After that,

press the wireless activation button on the tool in the same way.

► **Fig.35:** 1. Wireless activation button 2. Wireless activation lamp

If the cancellation is performed successfully, the wireless activation lamps will light up in red for 2 seconds and start blinking in blue.

NOTE: The wireless activation lamps finish blinking in red after 20 seconds elapsed. Press the wireless activation button on the tool while the wireless activation lamp on the cleaner is blinking. If the wireless activation lamp does not blink in red, push the wireless activation button briefly and hold it down again.

Troubleshooting for wireless activation function

Before asking for repairs, conduct your own inspection first. If you find a problem that is not explained in the manual, do not attempt to dismantle the tool. Instead, ask Makita Authorized Service Centers, always using Makita replacement parts for repairs.

State of abnormality	Probable cause (malfunction)	Remedy
The wireless activation lamp does not light/blink.	The wireless unit is not installed into the tool. The wireless unit is improperly installed into the tool.	Install the wireless unit correctly.
	The terminal of the wireless unit and/or the slot is dirty.	Gently wipe off dust and dirt on the terminal of the wireless unit and clean the slot.
	The wireless activation button on the tool has not been pushed.	Push the wireless activation button on the tool briefly.
	The stand-by switch on the vacuum cleaner is not set to "AUTO".	Set the stand-by switch on the vacuum cleaner to "AUTO".
	No power supply	Supply the power to the tool and the vacuum cleaner.
Cannot finish tool registration / cancelling tool registration successfully.	The wireless unit is not installed into the tool. The wireless unit is improperly installed into the tool.	Install the wireless unit correctly.
	The terminal of the wireless unit and/or the slot is dirty.	Gently wipe off dust and dirt on the terminal of the wireless unit and clean the slot.
	The stand-by switch on the vacuum cleaner is not set to "AUTO".	Set the stand-by switch on the vacuum cleaner to "AUTO".
	No power supply	Supply the power to the tool and the vacuum cleaner.
	Incorrect operation	Push the wireless activation button briefly and perform the tool registration/cancellation procedures again.
	The tool and vacuum cleaner are away from each other (out of the transmission range).	Get the tool and vacuum cleaner closer to each other. The maximum transmission distance is approximately 10 m however it may vary according to the circumstances.
	Before finishing the tool registration/cancellation; - the switch of the tool is turned on or; - the power button on the vacuum cleaner is turned on.	Push the wireless activation button briefly and perform the tool registration/cancellation procedures again.
	The tool registration procedures for the tool or vacuum cleaner have not finished.	Perform the tool registration procedures for both the tool and the vacuum cleaner at the same timing.
Radio disturbance by other appliances which generate high-intensity radio waves.	Keep the tool and vacuum cleaner away from the appliances such as Wi-Fi devices and microwave ovens.	



State of abnormality	Probable cause (malfunction)	Remedy
The vacuum cleaner does not run along with the switch operation of the tool.	The wireless unit is not installed into the tool. The wireless unit is improperly installed into the tool.	Install the wireless unit correctly.
	The terminal of the wireless unit and/or the slot is dirty.	Gently wipe off dust and dirt on the terminal of the wireless unit and clean the slot.
	The wireless activation button on the tool has not been pushed.	Push the wireless activation button briefly and make sure that the wireless activation lamp is blinking in blue.
	The stand-by switch on the vacuum cleaner is not set to "AUTO".	Set the stand-by switch on the vacuum cleaner to "AUTO".
	More than 10 tools are registered to the vacuum cleaner.	Perform the tool registration again. If more than 10 tools are registered to the vacuum cleaner, the tool registered earliest will be cancelled automatically.
	The vacuum cleaner erased all tool registrations.	Perform the tool registration again.
	No power supply	Supply the power to the tool and the vacuum cleaner.
	The tool and vacuum cleaner are away from each other (out of the transmission range).	Get the tool and vacuum cleaner closer each other. The maximum transmission distance is approximately 10 m however it may vary according to the circumstances.
	Radio disturbance by other appliances which generate high-intensity radio waves.	Keep the tool and vacuum cleaner away from the appliances such as Wi-Fi devices and microwave ovens.
The vacuum cleaner runs while the tool is not operating.	Other users are using the wireless activation of the vacuum cleaner with their tools.	Turn off the wireless activation button of the other tools or cancel the tool registration of the other tools.

MAINTENANCE

⚠ CAUTION: Always be sure that the tool is switched off and the battery cartridge is removed before attempting to perform inspection or maintenance.

NOTICE: Never use gasoline, benzene, thinner, alcohol or the like. Discoloration, deformation or cracks may result.

To maintain product SAFETY and RELIABILITY, repairs, any other maintenance or adjustment should be performed by Makita Authorized or Factory Service Centers, always using Makita replacement parts.

Replacing plate

Optional accessory

- Loosen the screws securing the plate and remove the plate.
 - Attach the strap washer, the carbon plate and the cork rubber plate or the steel plate to the screw holes of the tool with screws as shown in the figure.
- ▶ **Fig.36:** 1. Screw 2. Strap washer 3. Carbon plate 4. Cork rubber plate 5. Steel plate 6. Screw hole

NOTE: The plate installed at the shipment differs from country to country.

OPTIONAL ACCESSORIES

⚠ CAUTION: These accessories or attachments are recommended for use with your Makita tool specified in this manual. The use of any other accessories or attachments might present a risk of injury to persons. Only use accessory or attachment for its stated purpose.

If you need any assistance for more details regarding these accessories, ask your local Makita Service Center.

- Sanding belts
- Guide rule
- Clamp
- Sanding shoe
- Carbon plate
- Cork rubber plate
- Hose complete 28
- Front cuffs
- Wireless unit
- Makita genuine battery and charger

NOTE: Some items in the list may be included in the tool package as standard accessories. They may differ from country to country.

SPÉCIFICATIONS

Modèle :	BS001G
Dimensions de la bande (l x L)	76 mm x 533 mm
Vitesse de la bande	120 - 470 m/min
Longueur totale	440 mm
Tension nominale	36 V - 40 V c.c. max.
Poids net	4,5 - 5,1 kg

- Étant donné l'évolution constante de notre programme de recherche et de développement, les spécifications contenues dans ce manuel sont sujettes à modification sans préavis.
- Les spécifications peuvent varier suivant les pays.
- Le poids peut être différent selon les accessoires, notamment la batterie. Les associations la plus légère et la plus lourde, conformément à la procédure EPTA 01/2014, sont indiquées dans le tableau.

Batterie et chargeur applicables

Batterie	BL4020 / BL4025 / BL4040 / BL4040F / BL4050F
Chargeur	DC40RA / DC40RB / DC40RC / DC40WA

- Certains chargeurs et batteries répertoriés ci-dessus peuvent ne pas être disponibles selon la région où vous résidez.

⚠ AVERTISSEMENT : N'utilisez que les batteries et les chargeurs répertoriés ci-dessus. L'utilisation d'autres batteries et chargeurs peut provoquer des blessures et/ou un incendie.

Source d'alimentation connectée par cordon recommandée

Support d'alimentation portable	PDC01 / PDC1200 / PDC1500
---------------------------------	---------------------------

- La ou les sources d'alimentation connectées par cordon répertoriées ci-dessus peuvent ne pas être disponibles selon la région où vous résidez.
- Avant d'utiliser la source d'alimentation connectée par cordon, lisez les instructions et les avertissements inscrits dessus.

Symboles

Vous trouverez ci-dessous les symboles susceptibles d'être utilisés pour l'appareil. Veuillez à comprendre leur signification avant toute utilisation.



Lire le mode d'emploi.



Portez une protection oculaire.



Ne relâchez pas les mains de l'outil pendant la rotation de la bande abrasive. L'outil pourrait fonctionner tout seul.



Ni-MH
Li-ion

Pour les pays de l'Union européenne uniquement

En raison de la présence de composants dangereux dans l'équipement, les déchets d'équipements électriques et électroniques, les accumulateurs et les batteries peuvent avoir un impact négatif sur l'environnement et la santé humaine.

Ne jetez pas les appareils électriques et électroniques ou les batteries avec les ordures ménagères !

Conformément à la directive européenne relative aux déchets d'équipements électriques et électroniques et aux déchets d'accumulateurs et de batteries, ainsi qu'à son adaptation à la législation nationale, les déchets d'équipements électriques, les batteries et les accumulateurs doivent être collectés séparément et déposés dans un point de collecte distinct pour déchets urbains, conformément aux réglementations en matière de protection de l'environnement.

Cela est indiqué par le symbole de la poubelle à roulettes barrée sur l'équipement.