

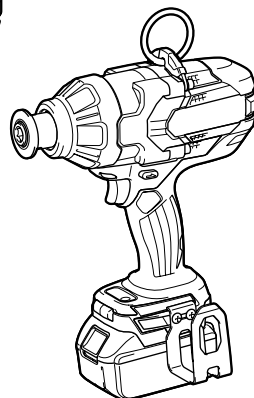

EN	Cordless Impact Wrench	INSTRUCTION MANUAL	4
SV	Sladdlös mutterdragare	BRUKSANVISNING	14
NO	Batteridrevet slagskruttrekker	BRUKSANVISNING	24
FI	Akkukäyttöinen iskevä mutterinväännin	KÄYTTÖOHJE	34
DA	Elektronisk akku slag nøgle	BRUGSANVISNING	44
LV	Bezvada triecienuzgriežņatslēga	LIETOŠANAS INSTRUKCIJA	54
LT	Belaidis smūginis veržliasukis	NAUDOJIMO INSTRUKCIJA	65
ET	Juhtmeta löökmutrivõti	KASUTUSJUHEND	75
RU	Акумуляторный ударный гайковерт	РУКОВОДСТВО ПО ЭКСПЛУАТАЦИИ	85

DTW1001
DTW1002
DTW1004
DTW800
DTW1001XV
DTW1002XV
DTW1004XV
DTW800XV

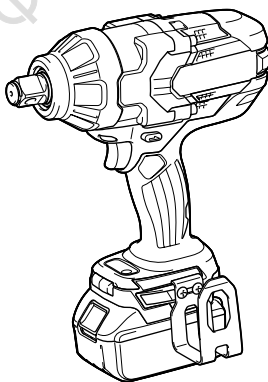

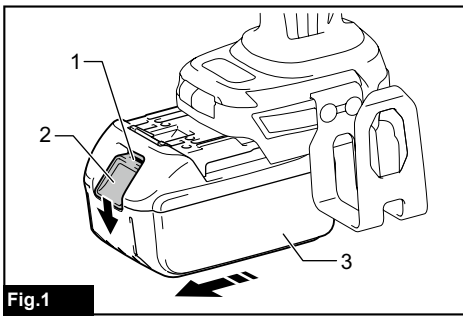

Fig.1

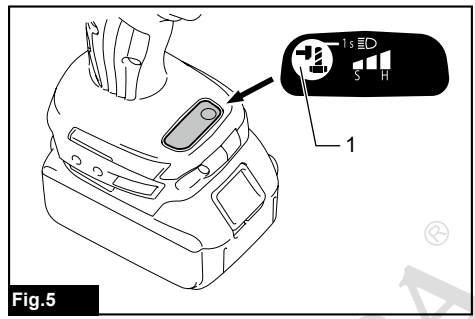

Fig.5

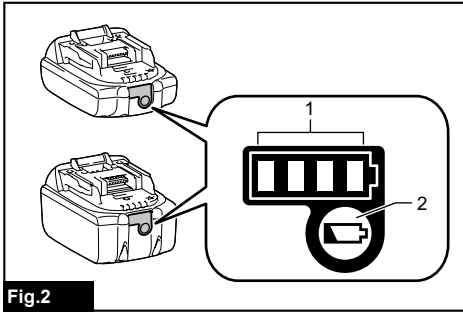

Fig.2

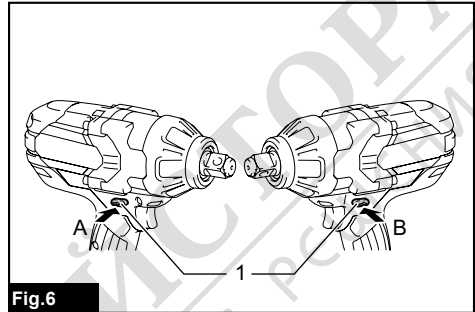

Fig.6

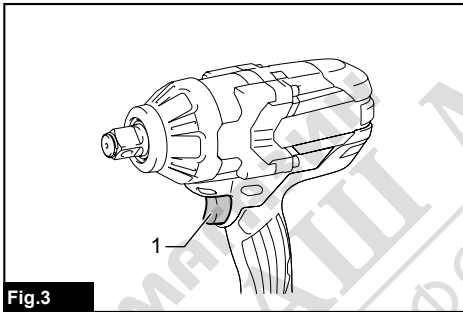

Fig.3

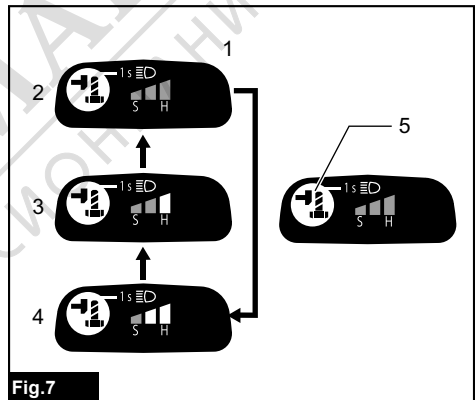

Fig.7

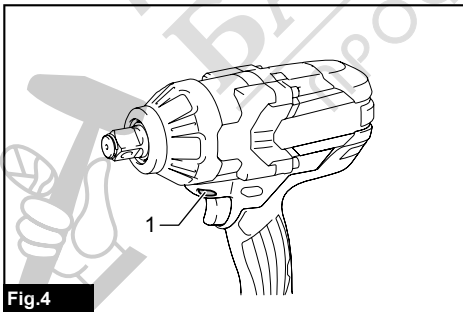

Fig.4

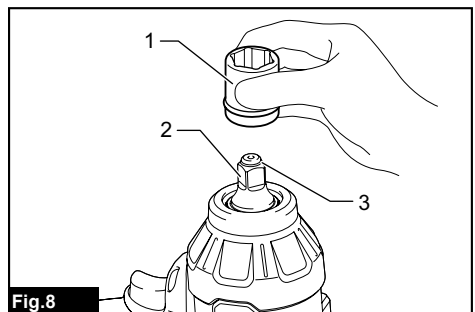

Fig.8

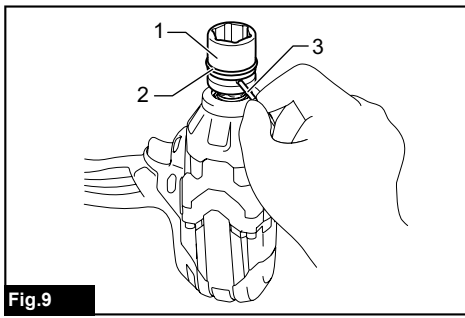

Fig.9

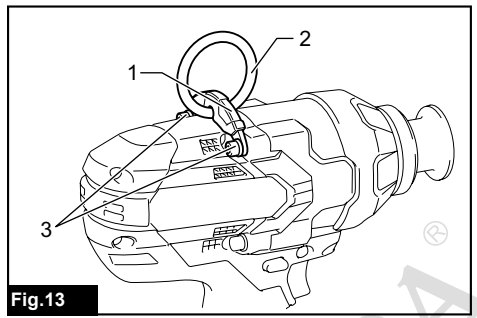

Fig.13

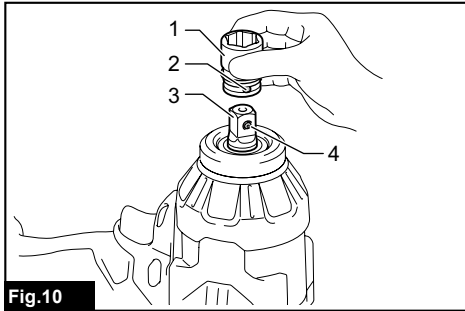

Fig.10

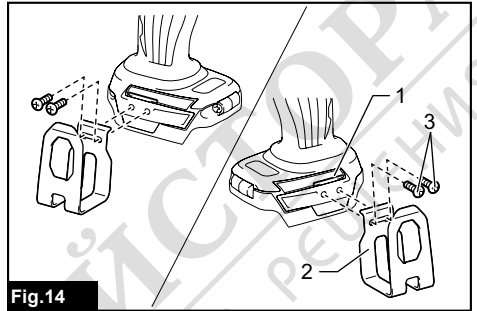

Fig.14

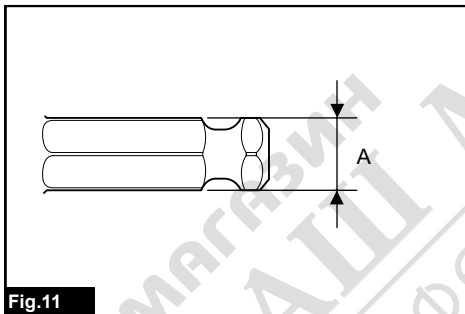

Fig.11

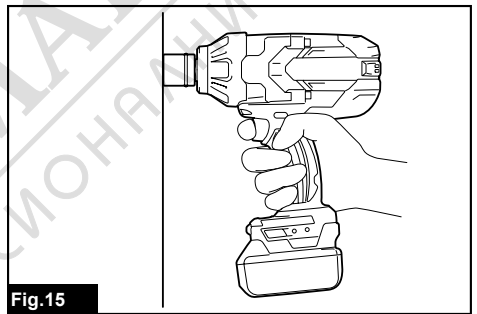

Fig.15

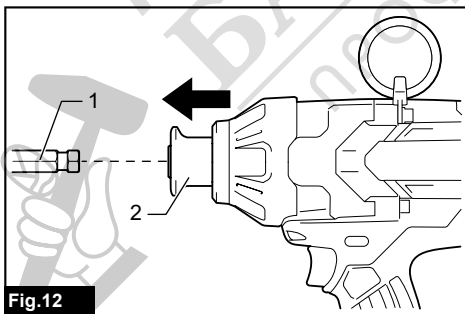

Fig.12

SPECIFICATIONS

Model:		DTW1001	DTW1001XV	DTW1002	DTW1002XV	DTW1004	DTW1004XV	DTW800	DTW800XV
Fastening capacities	Standard bolt	M12 - M30						M12 - M24	
	High tensile bolt	M10 - M24						M10 - M22	
Square drive		19 mm			12.7 mm			-	
Drive shank		-						11.1 mm Hex.	
No load speed (RPM)	Hard impact mode	0 - 1,800 min ⁻¹			0 - 2,000 min ⁻¹			0 - 1,800 min ⁻¹	
	Medium impact mode	0 - 1,000 min ⁻¹							
	Soft impact mode	0 - 900 min ⁻¹							
Impacts per minute	Hard impact mode	0 - 2,200 min ⁻¹			0 - 2,400 min ⁻¹			0 - 2,200 min ⁻¹	
	Medium impact mode	0 - 2,000 min ⁻¹							
	Soft impact mode	0 - 1,800 min ⁻¹							
Overall length		229 mm			223 mm			229 mm	
Rated voltage		D.C. 18 V							
For use near high-voltage electrical power lines		-	✓	-	✓	-	✓	-	✓
Net weight		3.4 - 3.7 kg		3.3 - 3.6 kg		3.1 - 3.4 kg		3.5 - 3.8 kg	

- Due to our continuing program of research and development, the specifications herein are subject to change without notice.
- Specifications may differ from country to country.
- The weight may differ depending on the attachment(s), including the battery cartridge. The lightest and heaviest combinations, according to EPTA-Procedure 01/2014, are shown in the table.

Applicable battery cartridge and charger

Battery cartridge	BL1815N / BL1820B / BL1830B / BL1840B / BL1850B / BL1860B
Charger	DC18RC / DC18RD / DC18RE / DC18SD / DC18SE / DC18SF / DC18SH / DC18WC

- Some of the battery cartridges and chargers listed above may not be available depending on your region of residence.

⚠ WARNING: Only use the battery cartridges and chargers listed above. Use of any other battery cartridges and chargers may cause injury and/or fire.

Intended use

The tool is intended for fastening bolts and nuts.
Model DTW800 / DTW800XV: The tool is also intended for drilling into wood.

Noise

The typical A-weighted noise level determined according to EN62841-2-2:

Model DTW1001 / DTW1001XV
Sound pressure level (L_{pA}): 101 dB (A)
Sound power level (L_{WA}): 109 dB (A)
Uncertainty (K): 3 dB (A)

Model DTW1002 / DTW1002XV
Sound pressure level (L_{pA}): 100 dB (A)
Sound power level (L_{WA}): 108 dB (A)
Uncertainty (K): 3 dB (A)

Model DTW1004 / DTW1004XV
Sound pressure level (L_{pA}): 98 dB (A)
Sound power level (L_{WA}): 106 dB (A)
Uncertainty (K): 3 dB (A)

Model DTW800 / DTW800XV
Sound pressure level (L_{pA}): 98 dB (A)
Sound power level (L_{WA}): 106 dB (A)
Uncertainty (K): 3 dB (A)

NOTE: The declared noise emission value(s) has been measured in accordance with a standard test method and may be used for comparing one tool with another.

NOTE: The declared noise emission value(s) may also be used in a preliminary assessment of exposure.

⚠WARNING: Wear ear protection.

⚠WARNING: The noise emission during actual use of the power tool can differ from the declared value(s) depending on the ways in which the tool is used especially what kind of workpiece is processed.

⚠WARNING: Be sure to identify safety measures to protect the operator that are based on an estimation of exposure in the actual conditions of use (taking account of all parts of the operating cycle such as the times when the tool is switched off and when it is running idle in addition to the trigger time).

Vibration

The vibration total value (tri-axial vector sum) determined according to EN62841-2-2:

Model DTW1001 / DTW1001XV

Work mode: impact tightening of fasteners of the maximum capacity of the tool

Vibration emission (a_h): 15.5 m/s²

Uncertainty (K): 2.0 m/s²

Model DTW1002 / DTW1002XV

Work mode: impact tightening of fasteners of the maximum capacity of the tool

Vibration emission (a_h): 18.0 m/s²

Uncertainty (K): 1.5 m/s²

Model DTW1004 / DTW1004XV

Work mode: impact tightening of fasteners of the maximum capacity of the tool

Vibration emission (a_h): 18.4 m/s²

Uncertainty (K): 1.7 m/s²

Model DTW800 / DTW800XV

Work mode: impact tightening of fasteners of the maximum capacity of the tool

Vibration emission (a_h): 24.0 m/s²

Uncertainty (K): 2.0 m/s²

Work mode: drilling into wood

Vibration emission (a_h): 7.0 m/s²

Uncertainty (K): 1.5 m/s²

NOTE: The declared vibration total value(s) has been measured in accordance with a standard test method and may be used for comparing one tool with another.

NOTE: The declared vibration total value(s) may also be used in a preliminary assessment of exposure.

⚠WARNING: The vibration emission during actual use of the power tool can differ from the declared value(s) depending on the ways in which the tool is used especially what kind of workpiece is processed.

⚠WARNING: Be sure to identify safety measures to protect the operator that are based on an estimation of exposure in the actual conditions of use (taking account of all parts of the operating cycle such as the times when the tool is switched off and when it is running idle in addition to the trigger time).

Declarations of Conformity

For European countries only

The Declarations of conformity are included in Annex A to this instruction manual.

SAFETY WARNINGS

General power tool safety warnings

⚠WARNING Read all safety warnings, instructions, illustrations and specifications provided with this power tool. Failure to follow all instructions listed below may result in electric shock, fire and/or serious injury.

Save all warnings and instructions for future reference.

The term "power tool" in the warnings refers to your mains-operated (corded) power tool or battery-operated (cordless) power tool.

Cordless impact wrench / impact drill safety warnings

For impact wrench

1. **Hold the power tool by insulated gripping surfaces, when performing an operation where the fastener may contact hidden wiring.** Fasteners contacting a "live" wire may make exposed metal parts of the power tool "live" and could give the operator an electric shock.

For impact drill

1. **Wear ear protectors when impact drilling.** Exposure to noise can cause hearing loss.
2. **Hold the power tool by insulated gripping surfaces, when performing an operation where the cutting accessory may contact hidden wiring.** Cutting accessory contacting a "live" wire may make exposed metal parts of the power tool "live" and could give the operator an electric shock.
3. **Use auxiliary handle(s), if supplied with the tool.** Loss of control can cause personal injury.
4. **Never operate at higher speed than the maximum speed rating of the drill bit.** At higher speeds, the bit is likely to bend if allowed to rotate freely without contacting the workpiece, resulting in personal injury.
5. **Always start drilling at low speed and with the bit tip in contact with the workpiece.** At higher speeds, the bit is likely to bend if allowed to rotate freely without contacting the workpiece, resulting in personal injury.
6. **Apply pressure only in direct line with the bit and do not apply excessive pressure.** Bits can bend causing breakage or loss of control, resulting in personal injury.

Additional safety warnings

1. **Wear ear protectors.**
2. **Check the impact socket carefully for wear, cracks or damage before installation.**
3. **Hold the tool firmly.**

4. **Always be sure you have a firm footing. Be sure no one is below when using the tool in high locations.**
5. **The proper fastening torque may differ depending upon the kind or size of the bolt. Check the torque with a torque wrench.**
6. **Keep hands away from rotating parts.**
7. **Do not touch the drill bit or the workpiece immediately after operation; they may be extremely hot and could burn your skin.**
8. **Some material contains chemicals which may be toxic. Take caution to prevent dust inhalation and skin contact. Follow material supplier safety data.**

SAVE THESE INSTRUCTIONS.

⚠WARNING: DO NOT let comfort or familiarity with product (gained from repeated use) replace strict adherence to safety rules for the subject product.

MISUSE or failure to follow the safety rules stated in this instruction manual may cause serious personal injury.

Important safety instructions for battery cartridge

1. **Before using battery cartridge, read all instructions and cautionary markings on (1) battery charger, (2) battery, and (3) product using battery.**
2. **Do not disassemble or tamper with the battery cartridge.** It may result in a fire, excessive heat, or explosion.
3. **If operating time has become excessively shorter, stop operating immediately.** It may result in a risk of overheating, possible burns and even an explosion.
4. **If electrolyte gets into your eyes, rinse them out with clear water and seek medical attention right away.** It may result in loss of your eyesight.
5. **Do not short the battery cartridge:**
 - (1) **Do not touch the terminals with any conductive material.**
 - (2) **Avoid storing battery cartridge in a container with other metal objects such as nails, coins, etc.**
 - (3) **Do not expose battery cartridge to water or rain.**

A battery short can cause a large current flow, overheating, possible burns and even a breakdown.
6. **Do not store and use the tool and battery cartridge in locations where the temperature may reach or exceed 50 °C (122 °F).**
7. **Do not incinerate the battery cartridge even if it is severely damaged or is completely worn out.** The battery cartridge can explode in a fire.
8. **Do not nail, cut, crush, throw, drop the battery cartridge, or hit against a hard object to the battery cartridge.** Such conduct may result in a fire, excessive heat, or explosion.
9. **Do not use a damaged battery.**

10. **The contained lithium-ion batteries are subject to the Dangerous Goods Legislation requirements.** For commercial transports e.g. by third parties, forwarding agents, special requirement on packaging and labeling must be observed. For preparation of the item being shipped, consulting an expert for hazardous material is required. Please also observe possibly more detailed national regulations. Tape or mask off open contacts and pack up the battery in such a manner that it cannot move around in the packaging.
11. **When disposing the battery cartridge, remove it from the tool and dispose of it in a safe place.** Follow your local regulations relating to disposal of battery.
12. **Use the batteries only with the products specified by Makita.** Installing the batteries to non-compliant products may result in a fire, excessive heat, explosion, or leak of electrolyte.
13. **If the tool is not used for a long period of time, the battery must be removed from the tool.**
14. **During and after use, the battery cartridge may take on heat which can cause burns or low temperature burns.** Pay attention to the handling of hot battery cartridges.
15. **Do not touch the terminal of the tool immediately after use as it may get hot enough to cause burns.**
16. **Do not allow chips, dust, or soil stuck into the terminals, holes, and grooves of the battery cartridge.** It may cause heating, catching fire, burst and malfunction of the tool or battery cartridge, resulting in burns or personal injury.
17. **Unless the tool supports the use near high-voltage electrical power lines, do not use the battery cartridge near high-voltage electrical power lines.** It may result in a malfunction or breakdown of the tool or battery cartridge.
18. **Keep the battery away from children.**

SAVE THESE INSTRUCTIONS.

⚠CAUTION: Only use genuine Makita batteries. Use of non-genuine Makita batteries, or batteries that have been altered, may result in the battery bursting causing fires, personal injury and damage. It will also void the Makita warranty for the Makita tool and charger.

Tips for maintaining maximum battery life

1. **Charge the battery cartridge before completely discharged. Always stop tool operation and charge the battery cartridge when you notice less tool power.**
2. **Never recharge a fully charged battery cartridge. Overcharging shortens the battery service life.**
3. **Charge the battery cartridge with room temperature at 10 °C - 40 °C (50 °F - 104 °F). Let a hot battery cartridge cool down before charging it.**
4. **When not using the battery cartridge, remove it from the tool or the charger.**
5. **Charge the battery cartridge if you do not use it for a long period (more than six months).**

FUNCTIONAL DESCRIPTION

CAUTION: Always be sure that the tool is switched off and the battery cartridge is removed before adjusting or checking function on the tool.

Installing or removing battery cartridge

CAUTION: Always switch off the tool before installing or removing of the battery cartridge.

CAUTION: Hold the tool and the battery cartridge firmly when installing or removing battery cartridge. Failure to hold the tool and the battery cartridge firmly may cause them to slip off your hands and result in damage to the tool and battery cartridge and a personal injury.

To install the battery cartridge, align the tongue on the battery cartridge with the groove in the housing and slip it into place. Insert it all the way until it locks in place with a little click. If you can see the red indicator as shown in the figure, it is not locked completely.

To remove the battery cartridge, slide it from the tool while sliding the button on the front of the cartridge.

► Fig.1: 1. Red indicator 2. Button 3. Battery cartridge

CAUTION: Always install the battery cartridge fully until the red indicator cannot be seen. If not, it may accidentally fall out of the tool, causing injury to you or someone around you.

CAUTION: Do not install the battery cartridge forcibly. If the cartridge does not slide in easily, it is not being inserted correctly.

Battery protection system

The tool is equipped with a battery protection system. This system automatically cuts off power to the motor to extend battery life.

The tool will automatically stop during operation if the tool and/or battery are placed under one of the following conditions:

Overload protection

The tool is operated in a manner that causes it to draw an abnormally high current. In this situation, turn the tool off and stop the application that caused the tool to become overloaded. Then turn the tool on to restart.

If the tool does not start, the battery is overheated. In this situation, let the battery cool before turning the tool on again.

Overdischarge protection

The remaining battery capacity is too low and the tool will not operate. In this situation, remove and recharge the battery.

Protections against other causes

Protection system is also designed for other causes that could damage the tool and allows the tool to stop automatically. Take all the following steps to clear the causes, when the tool has been brought to a temporary halt or stop in operation.

1. Turn the tool off, and then turn it on again to restart.
2. Charge the battery(ies) or replace it/them with recharged battery(ies).
3. Let the tool and battery(ies) cool down.

If no improvement can be found by restoring protection system, then contact your local Makita Service Center.

Indicating the remaining battery capacity

Only for battery cartridges with the indicator

► Fig.2: 1. Indicator lamps 2. Check button

Press the check button on the battery cartridge to indicate the remaining battery capacity. The indicator lamps light up for a few seconds.

Indicator lamps			Remaining capacity
Lighted	Off	Blinking	
			75% to 100%
			50% to 75%
			25% to 50%
			0% to 25%
			Charge the battery.
			The battery may have malfunctioned.

NOTE: Depending on the conditions of use and the ambient temperature, the indication may differ slightly from the actual capacity.

NOTE: The first (far left) indicator lamp will blink when the battery protection system works.

Switch action

CAUTION: Before installing the battery cartridge into the tool, always check to see that the switch trigger actuates properly and returns to the "OFF" position when released.

To start the tool, simply pull the switch trigger. Tool speed is increased by increasing pressure on the switch trigger. Release the switch trigger to stop.

► Fig.3: 1. Switch trigger



NOTE: The tool automatically stops if you keep pulling the switch trigger for about 6 minutes.

Electric brake

This tool is equipped with an electric brake. If the tool consistently fails to quickly stop after the switch trigger is released, have the tool serviced at a Makita service center.

Lighting up the front lamp

CAUTION: Do not look in the light or see the source of light directly.

To turn on the lamp status, press the button  for one second. To turn off the lamp status, press the button  for one second again. With the lamp status ON, pull the switch trigger to turn on the lamp. To turn off, release it. The lamp goes out approximately 10 seconds after releasing the switch trigger. With the lamp status OFF, the lamp does not turn on even if pulling the trigger.

► **Fig.4:** 1. Lamp

► **Fig.5:** 1. Button

NOTE: To confirm the lamp status, pull the trigger. When the lamp lights up by pulling the switch trigger, the lamp status is ON. When the lamp does not come on, the lamp status is OFF.

NOTE: When the tool is overheated, the light flashes for one minute, and then the LED display goes off. In this case, cool down the tool before operating again.

NOTE: Use a dry cloth to wipe the dirt off the lens of the lamp. Be careful not to scratch the lens of lamp, or it may lower the illumination.

NOTE: While pulling the switch trigger, the lamp status cannot be changed.

NOTE: For approximately 10 seconds after releasing the switch trigger, the lamp status can be changed.

Reversing switch action

CAUTION: Always check the direction of rotation before operation.

CAUTION: Use the reversing switch only after the tool comes to a complete stop. Changing the direction of rotation before the tool stops may damage the tool.

CAUTION: When not operating the tool, always set the reversing switch lever to the neutral position. 

This tool has a reversing switch to change the direction of rotation. Depress the reversing switch lever from the A side for clockwise rotation or from the B side for counterclockwise rotation.

When the reversing switch lever is in the neutral position, the switch trigger cannot be pulled.

► **Fig.6:** 1. Reversing switch lever

Changing the impact force

You can change the impact in three steps: hard, medium and soft mode.

This allows a tightening suitable to the work.

Every time the button  is pressed, the number of blows changes in three steps.

You can change the impact force within approximately one minute after releasing the switch trigger.



► **Fig.7:** 1. Changed in three steps 2. Hard 3. Medium

4. Soft 5. Button

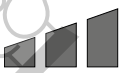
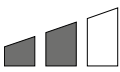
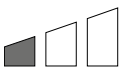
Specifications of each impact force grade

Impact force grade displayed on panel	Maximum blows				Application
	DTW1001 / DTW1001XV	DTW1002 / DTW1002XV	DTW1004 / DTW1004XV	DTW800 / DTW800XV	
 <p>Hard</p>	2,200 min ⁻¹ (/min)		2,400 min ⁻¹ (/min)	2,200 min ⁻¹ (/min)	Tightening when force and speed are desired.
 <p>Medium</p>	2,000 min ⁻¹ (/min)				Tightening when you need good controlled power.
 <p>Soft</p>	1,800 min ⁻¹ (/min)				Tightening when you need fine adjustment with small diameter bolt.

Impact force/bolt size corresponding chart (reference)

Impact force grade displayed on panel	DTW1001 / DTW1001XV		DTW1002 / DTW1002XV		DTW1004 / DTW1004XV		DTW800 / DTW800XV	
	Standard bolt	High tensile bolt	Standard bolt	High tensile bolt	Standard bolt	High tensile bolt	Standard bolt	High tensile bolt
Hard 	M20 - M30 (3/4" - 1-1/4")	M16 - M24 (5/8" - 1")	M20 - M30 (3/4" - 1-1/4")	M16 - M24 (5/8" - 1")	M20 - M30 (3/4" - 1-1/4")	M16 - M24 (5/8" - 1")	M20 - M24 (3/4" - 1")	M16 - M22 (5/8" - 7/8")
Medium 	M16 - M24 (5/8" - 1")	M12 - M20 (1/2" - 3/4")	M16 - M24 (5/8" - 1")	M12 - M20 (1/2" - 3/4")	M14 - M20 (9/16" - 3/4")	M10 - M16 (3/8" - 5/8")	M14 - M20 (9/16" - 3/4")	M10 - M16 (3/8" - 5/8")
Soft 	M12 - M20 (1/2" - 3/4")	M10 - M16 (3/8" - 5/8")	M12 - M20 (1/2" - 3/4")	M10 - M16 (3/8" - 5/8")	M12 - M16 (1/2" - 5/8")	M10 - M14 (3/8" - 9/16")	M12 - M16 (1/2" - 5/8")	M10 - M12 (3/8" - 1/2")

ASSEMBLY

CAUTION: Always be sure that the tool is switched off and the battery cartridge is removed before carrying out any work on the tool.

Selecting correct impact socket

Always use the correct size impact socket for bolts and nuts. An incorrect size impact socket will result in inaccurate and inconsistent fastening torque and/or damage to the bolt or nut.

Installing or removing impact socket

Optional accessory

CAUTION: Make sure that the impact socket and the mounting portion are not damaged before installing the impact socket.

CAUTION: After inserting the impact socket, make sure that it is firmly secured. If it comes out, do not use it.

Tool with the ring spring

For impact socket without O-ring and pin

Only for Model DTW1001 / DTW1002 / DTW1001XV / DTW1002XV

Align the square of the impact socket with the square drive and push the impact socket onto the square drive until it locks into place. Tap it lightly if required.

To remove the impact socket, simply pull it off.

► **Fig.8:** 1. Impact socket 2. Square drive 3. Ring spring

For impact socket with O-ring and pin

Only for Model DTW1001 / DTW1001XV

Move the O-ring out of the groove in the impact socket and remove the pin from the impact socket. Fit the impact socket onto the square drive so that the hole in the impact socket is aligned with the hole in the square drive.

Insert the pin through the hole in the impact socket and square drive. Then return the O-ring to the original position in the impact socket groove to retain the pin.

To remove the impact socket, follow the installation procedures in reverse.

► **Fig.9:** 1. Impact socket 2. O-ring 3. Pin

Tool with the detent pin

Only for Model DTW1004 / DTW1004XV

Align the hole in the side of the impact socket with the detent pin on the square drive and push the impact socket onto the square drive until it locks into place. Tap it lightly if required.

To remove the impact socket, simply pull it off. If it is hard to remove, depress the detent pin while pulling the impact socket.

► **Fig.10:** 1. Impact socket 2. Hole 3. Square drive 4. Detent pin

Installing or removing drill bit/ socket adapter

Optional accessory

Only for Model DTW800 / DTW800XV

► Fig.11

A=11.1 mm

Use only the drill bit/socket adapter shown in the figure. Do not use any other drill bit/socket adapter.

► Fig.12: 1. Drill bit 2. Sleeve

To install the drill bit, pull the sleeve in the direction of the arrow and insert the drill bit into the sleeve as far as it will go. Then release the sleeve to secure the drill bit.

To remove the drill bit, pull the sleeve in the direction of the arrow and pull the drill bit out.

NOTE: If the drill bit is not inserted deep enough into the sleeve, the sleeve will not return to its original position and the drill bit will not be secured. In this case, try re-inserting the drill bit according to the instructions above.

NOTE: After inserting the drill bit, make sure that it is firmly secured. If it comes out, do not use it.

Ring

Country specific

CAUTION: Before using the ring, always make sure that the bracket and ring are secured and not damaged.

CAUTION: Use the hanging/mounting parts for their intended purposes only. Using for unintended purpose may cause accident or personal injury.

The ring is convenient for hanging the tool with hoist. First, place the rope through the ring. Then hang the tool up to the air with hoist.

► Fig.13: 1. Bracket 2. Ring 3. Screws

Installing hook

WARNING: Use the hanging/mounting parts for their intended purposes only, e.g., hanging the tool on a tool belt between jobs or work intervals.

WARNING: Be careful not to overload the hook as too much force or irregular overburden may cause damages to the tool resulting in personal injury.

CAUTION: When installing the hook, always secure it with the screw firmly. If not, the hook may come off from the tool and result in the personal injury.

CAUTION: Make sure to hang the tool securely before releasing your hold. Insufficient or unbalanced hooking may cause falling off and you may be injured.

The hook is convenient for temporarily hanging the tool. This can be installed on either side of the tool. To install the hook, insert it into a groove in the tool housing on either side and then secure it with two screws. To remove, loosen the screws and then take it out.

► Fig.14: 1. Groove 2. Hook 3. Screw

OPERATION

CAUTION: Always insert the battery cartridge all the way until it locks in place. If you can see the red indicator on the upper side of the button, it is not locked completely. Insert it fully until the red indicator cannot be seen. If not, it may accidentally fall out of the tool, causing injury to you or someone around you.

Hold the tool firmly and place the impact socket over the bolt or nut. Turn the tool on and fasten for the proper fastening time.

The proper fastening torque may differ depending upon the kind or size of the bolt, the material of the workpiece to be fastened, etc. The relation between fastening torque and fastening time is shown in the figures.

► Fig.15

Proper fastening torque for standard bolt

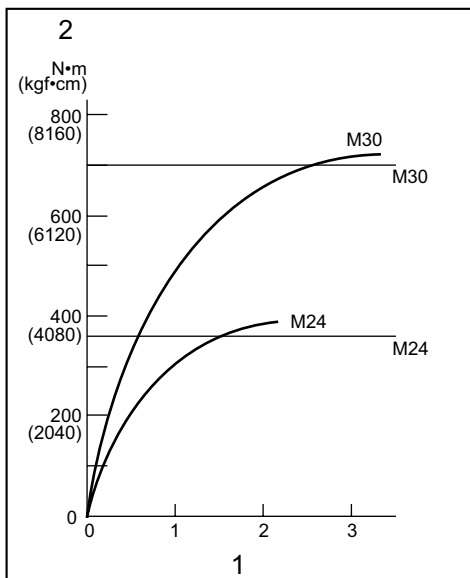

1. Fastening time (second) 2. Fastening torque

Proper fastening torque for standard bolt

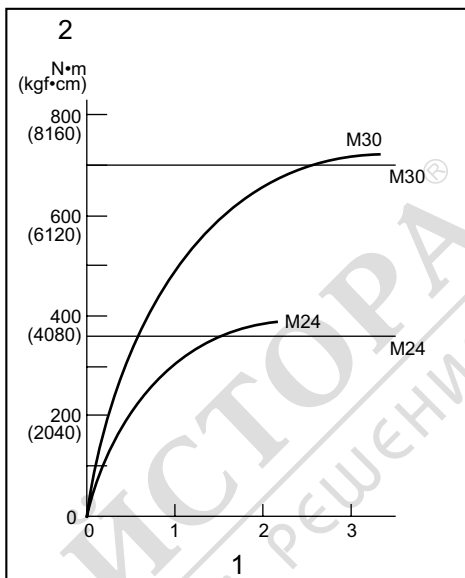

1. Fastening time (second) 2. Fastening torque

Proper fastening torque for high tensile bolt

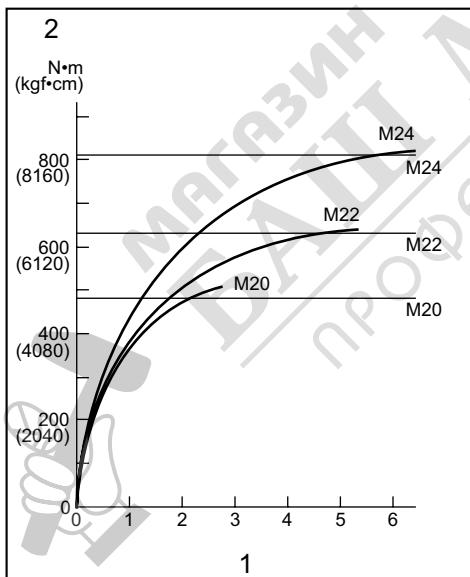

1. Fastening time (second) 2. Fastening torque

Proper fastening torque for high tensile bolt

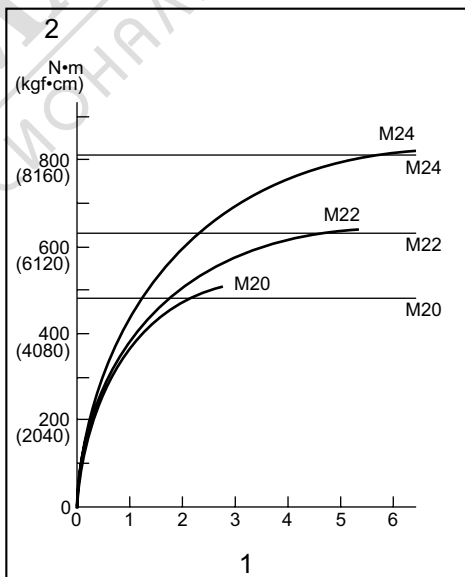

1. Fastening time (second) 2. Fastening torque

Proper fastening torque for standard bolt

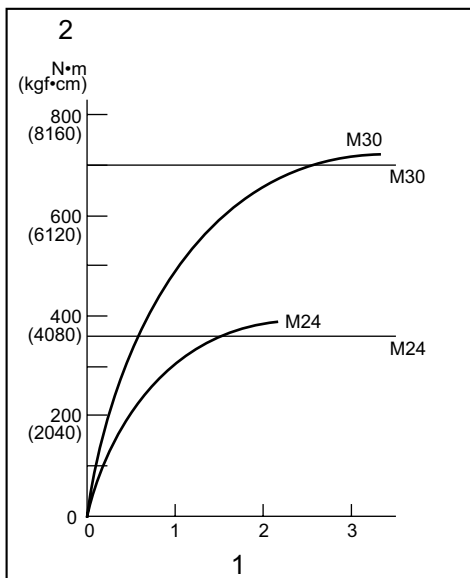

1. Fastening time (second) 2. Fastening torque

Proper fastening torque for standard bolt

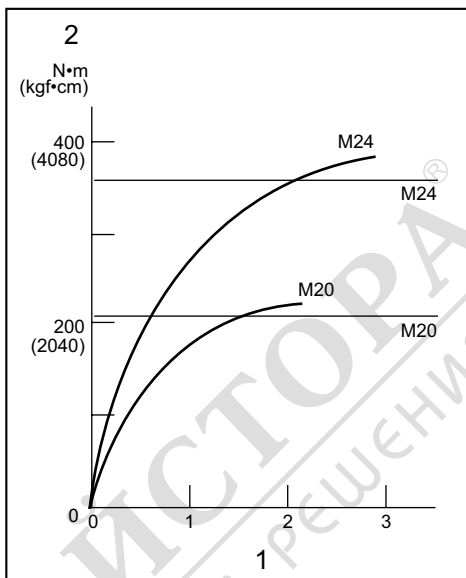

1. Fastening time (second) 2. Fastening torque

Proper fastening torque for high tensile bolt

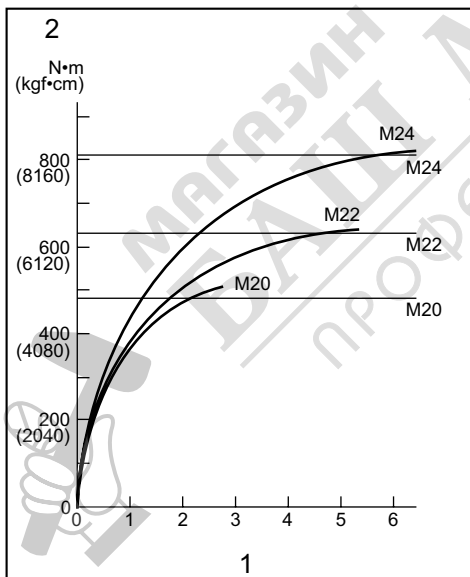

1. Fastening time (second) 2. Fastening torque

Proper fastening torque for high tensile bolt

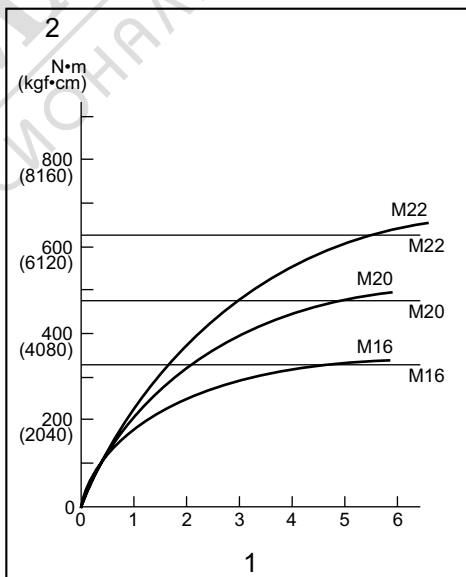

1. Fastening time (second) 2. Fastening torque

NOTE: Hold the tool pointed straight at the bolt or nut.

NOTE: Excessive fastening torque may damage the bolt/nut or impact socket. Before starting your job, always perform a test operation to determine the proper fastening time for your bolt or nut.

NOTE: If the tool is operated continuously until the battery cartridge has discharged, allow the tool to rest for 15 minutes before proceeding with a fresh battery cartridge.

The fastening torque is affected by a wide variety of factors including the following. After fastening, always check the torque with a torque wrench.

1. When the battery cartridge is discharged almost completely, voltage will drop and the fastening torque will be reduced.
2. Impact socket
 - Failure to use the correct size impact socket will cause a reduction in the fastening torque.
 - A worn impact socket (wear on the hex end or square end) will cause a reduction in the fastening torque.
3. Bolt
 - Even though the torque coefficient and the class of bolt are the same, the proper fastening torque will differ according to the diameter of bolt.
 - Even though the diameters of bolts are the same, the proper fastening torque will differ according to the torque coefficient, the class of bolt and the bolt length.
4. The use of the universal joint or the extension bar somewhat reduces the fastening force of the impact wrench. Compensate by fastening for a longer period of time.
5. The manner of holding the tool or the material of driving position to be fastened will affect the torque.
6. Operating the tool at low speed will cause a reduction in the fastening torque.

MAINTENANCE

CAUTION: Always be sure that the tool is switched off and the battery cartridge is removed before attempting to perform inspection or maintenance.

NOTICE: Never use gasoline, benzine, thinner, alcohol or the like. Discoloration, deformation or cracks may result.

To maintain product SAFETY and RELIABILITY, repairs, any other maintenance or adjustment should be performed by Makita Authorized or Factory Service Centers, always using Makita replacement parts.

OPTIONAL ACCESSORIES

CAUTION: These accessories or attachments are recommended for use with your Makita tool specified in this manual. The use of any other accessories or attachments might present a risk of injury to persons. Only use accessory or attachment for its stated purpose.

If you need any assistance for more details regarding these accessories, ask your local Makita Service Center.

- Impact socket
- Drill bits (only for Model DTW800 / DTW800XV)
- Extension bar
- Universal joint
- Pin 4 Set (only for Model DTW1004 / DTW1004XV)
- Extension handle
- Makita genuine battery and charger

NOTE: Some items in the list may be included in the tool package as standard accessories. They may differ from country to country.