

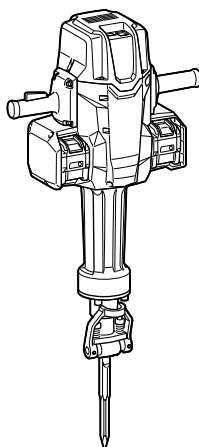

EN	Cordless Breaker	INSTRUCTION MANUAL	7
FR	Burineur sans fil	MANUEL D'INSTRUCTIONS	18
DE	Akku-Abbruchhammer	BETRIEBSANLEITUNG	29
IT	Martello demolitore a batteria	ISTRUZIONI PER L'USO	41
NL	Accusloophamer	GEBRUIKSAANWIJZING	53
ES	Rompedor Inalámbrico	MANUAL DE INSTRUCCIONES	65
PT	Martelo Demolidor a Bateria	MANUAL DE INSTRUÇÕES	77
EL	Φορητό κατεδαφιστικό	ΕΓΧΕΙΡΙΔΙΟ ΟΔΗΓΙΩΝ	88
TR	Akülü Kırıcı	KULLANMA KILAVUZU	100

HM004G

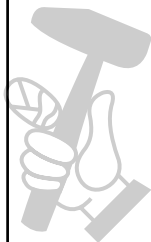

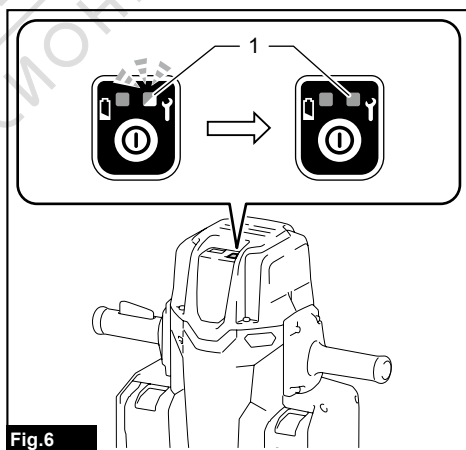
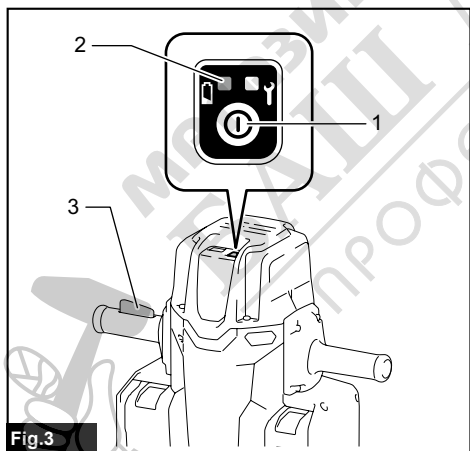
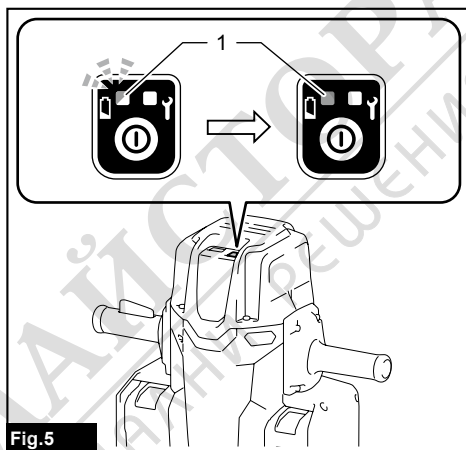
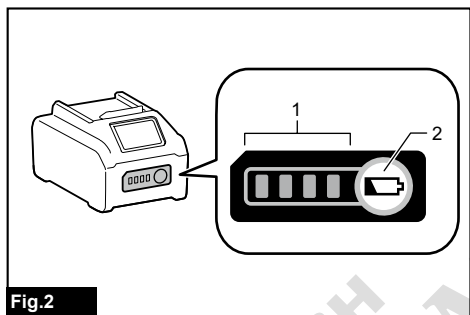
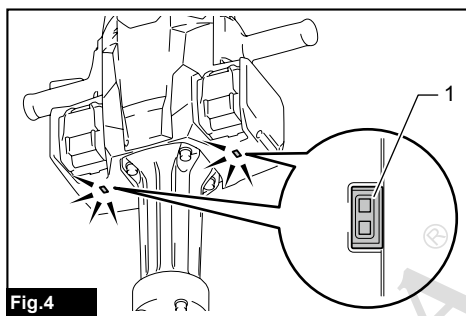
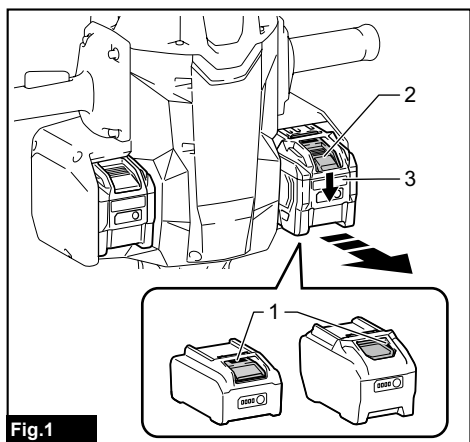

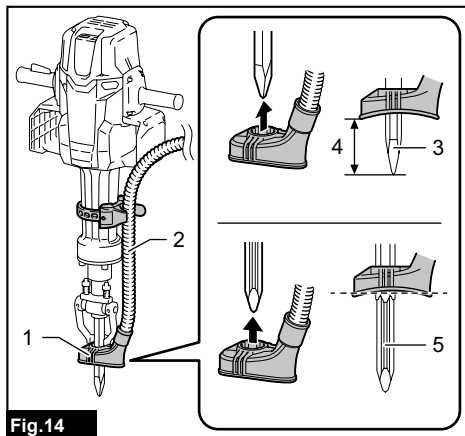
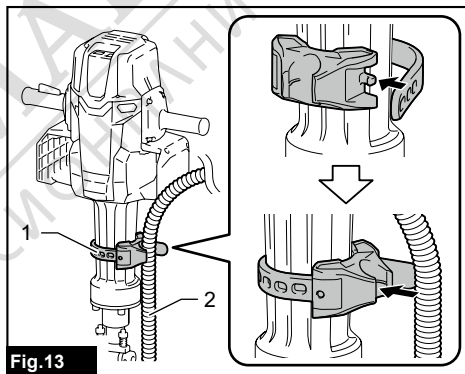
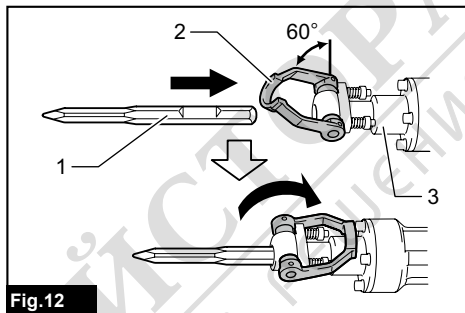
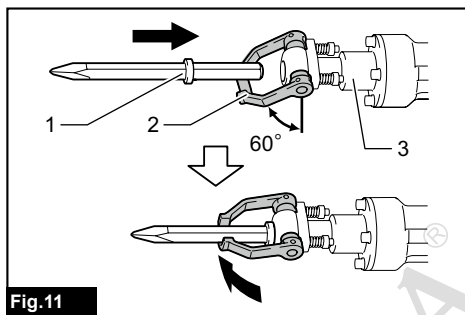
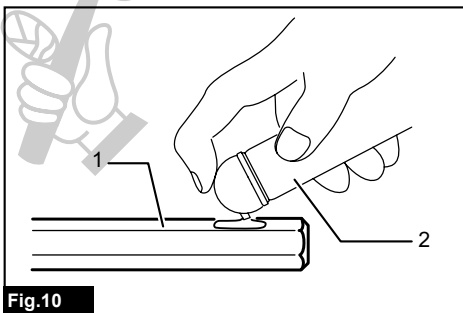
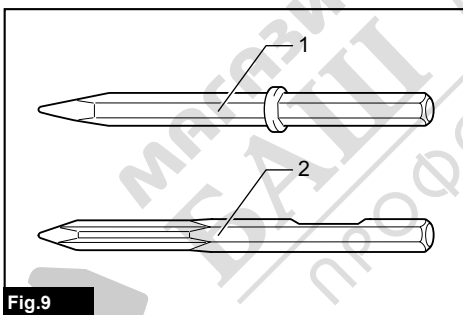
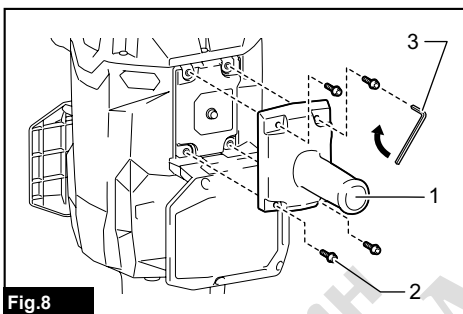
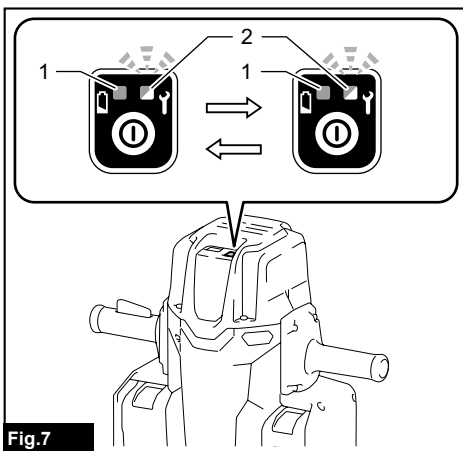

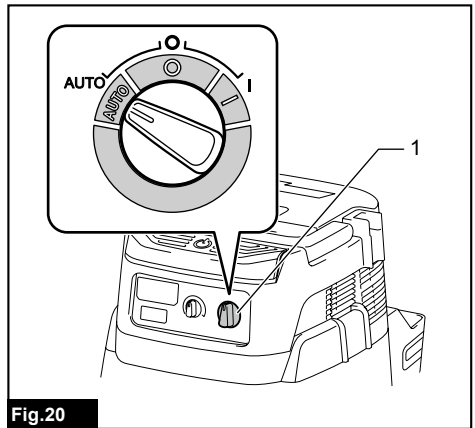
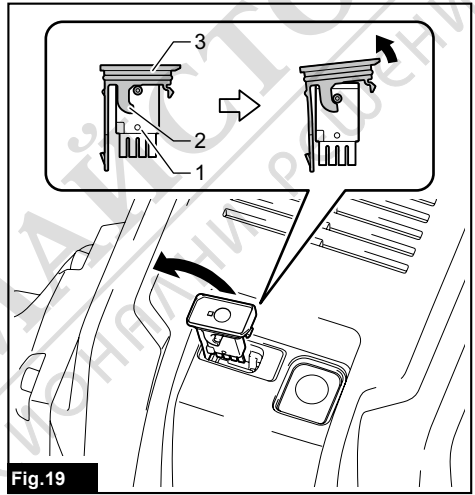
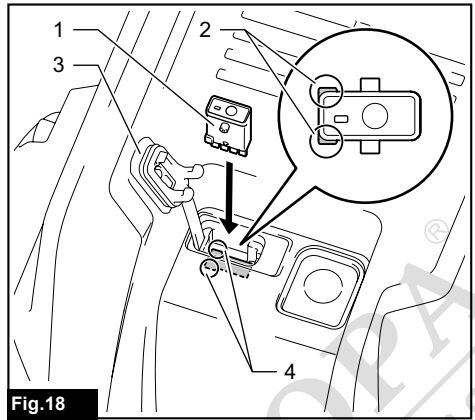
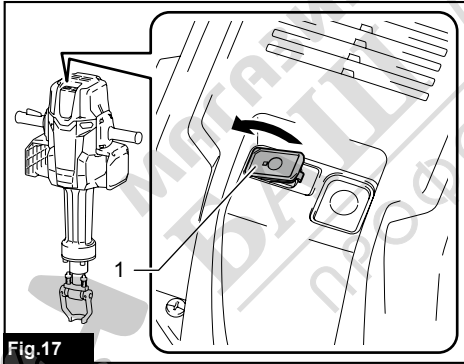
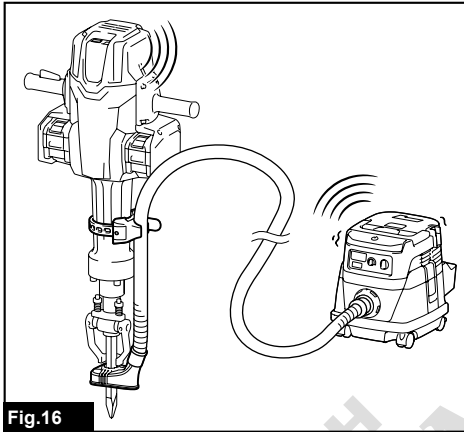
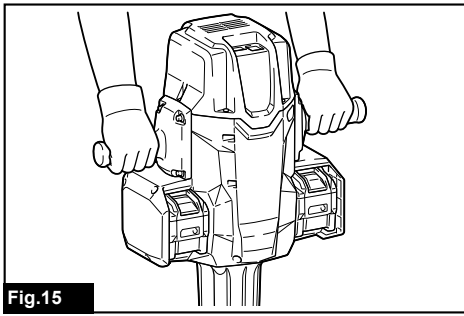

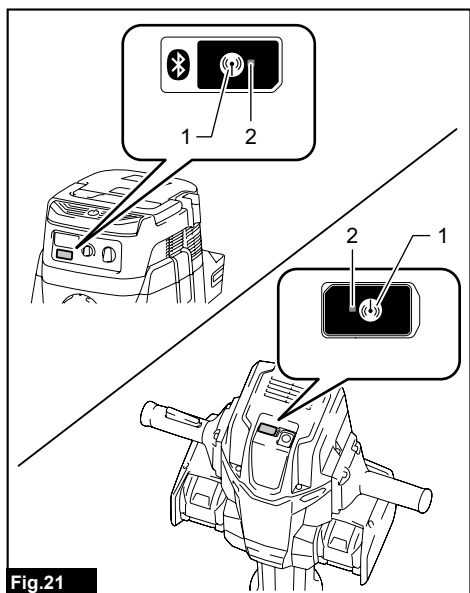

Fig.21

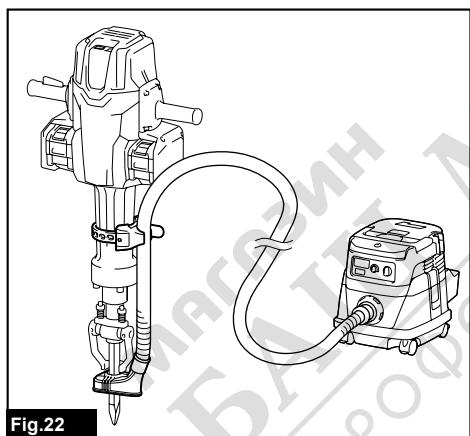

Fig.22

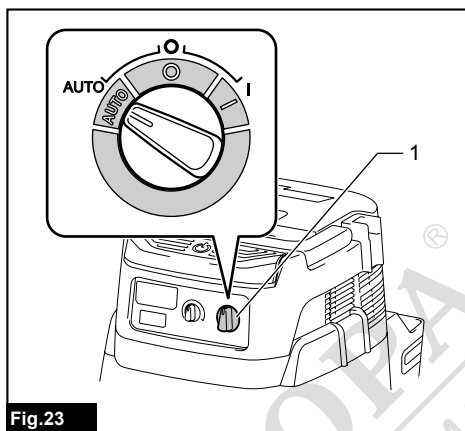

Fig.23

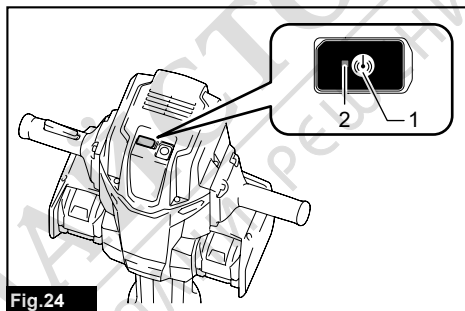

Fig.24

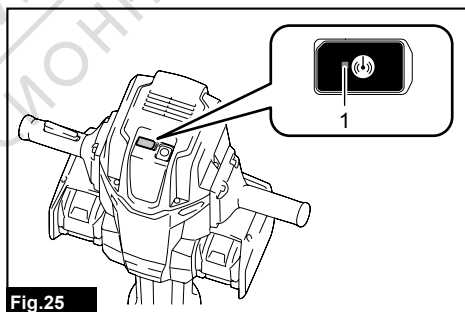
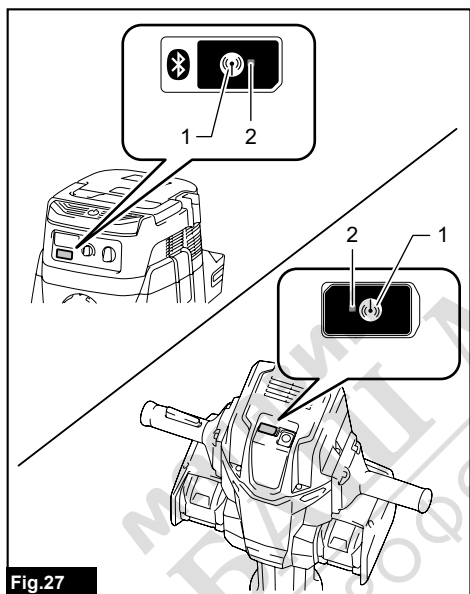
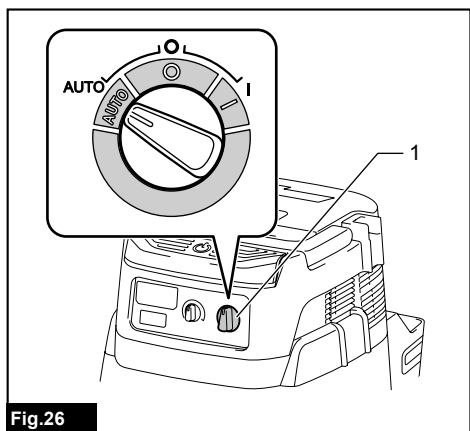

Fig.25





SPECIFICATIONS

Model:	HM004G
Blows per minute	870 min ⁻¹
Rated voltage	D.C. 72 V - 80 V max
Overall length	882 mm
Net weight	29.7 - 32.1 kg

- Due to our continuing program of research and development, the specifications herein are subject to change without notice.
- Specifications may differ from country to country.
- The weight may differ depending on the attachment(s), including the battery cartridge. The lightest and heaviest combinations, according to EPTA-Procedure 01/2014, are shown in the table.

Applicable battery cartridge and charger

Battery cartridge	BL4020 / BL4025 / BL4040* / BL4040F* / BL4050F* / BL4080F* * : Recommended battery
Charger	DC40RA / DC40RB / DC40RC / DC40WA

- Some of the battery cartridges and chargers listed above may not be available depending on your region of residence.

⚠ WARNING: Only use the battery cartridges and chargers listed above. Use of any other battery cartridges and chargers may cause injury and/or fire.

Symbols

The followings show the symbols which may be used for the equipment. Be sure that you understand their meaning before use.



Read instruction manual.



Only for EU countries
Due to the presence of hazardous components in the equipment, waste electrical and electronic equipment, accumulators and batteries may have a negative impact on the environment and human health. Do not dispose of electrical and electronic appliances or batteries with household waste!
In accordance with the European Directive on waste electrical and electronic equipment and on accumulators and batteries and waste accumulators and batteries, as well as their adaptation to national law, waste electrical equipment, batteries and accumulators should be stored separately and delivered to a separate collection point for municipal waste, operating in accordance with the regulations on environmental protection.
This is indicated by the symbol of the crossed-out wheeled bin placed on the equipment.



Guaranteed sound power level according to EU Outdoor Noise Directive.

Intended use

The tool is intended for heavy chiselling and demolition work as well as for driving and compacting with appropriate accessories.

Noise

The typical A-weighted noise level determined according to EN62841-2-6:

Sound pressure level (L_{pA}) : 95 dB (A)
Sound power level (L_{WA}) : 103 dB (A)
Uncertainty (K) : 1.62 dB (A)

NOTE: The declared noise emission value(s) has been measured in accordance with a standard test method and may be used for comparing one tool with another.

NOTE: The declared noise emission value(s) may also be used in a preliminary assessment of exposure.

⚠ WARNING: Wear ear protection.

⚠ WARNING: The noise emission during actual use of the power tool can differ from the declared value(s) depending on the ways in which the tool is used especially what kind of workpiece is processed.

⚠ WARNING: Be sure to identify safety measures to protect the operator that are based on an estimation of exposure in the actual conditions of use (taking account of all parts of the operating cycle such as the times when the tool is switched off and when it is running idle in addition to the trigger time).

Vibration

The vibration total value (tri-axial vector sum) determined according to EN62841-2-6:

Work mode: chiselling

Vibration emission ($a_{h, \text{Chis}}$): 6.5 m/s²

Uncertainty (K) : 1.5 m/s²

NOTE: The declared vibration total value(s) has been measured in accordance with a standard test method and may be used for comparing one tool with another.

NOTE: The declared vibration total value(s) may also be used in a preliminary assessment of exposure.

⚠WARNING: The vibration emission during actual use of the power tool can differ from the declared value(s) depending on the ways in which the tool is used especially what kind of workpiece is processed.

⚠WARNING: Be sure to identify safety measures to protect the operator that are based on an estimation of exposure in the actual conditions of use (taking account of all parts of the operating cycle such as the times when the tool is switched off and when it is running idle in addition to the trigger time).

Declarations of Conformity

For European countries only

The Declarations of conformity are included in Annex A to this instruction manual.

SAFETY WARNINGS

General power tool safety warnings

⚠WARNING Read all safety warnings, instructions, illustrations and specifications provided with this power tool. Failure to follow all instructions listed below may result in electric shock, fire and/or serious injury.

Save all warnings and instructions for future reference.

The term "power tool" in the warnings refers to your mains-operated (corded) power tool or battery-operated (cordless) power tool.

Cordless Breaker safety warnings

Safety instructions for all operations

1. **Wear ear protectors.** Exposure to noise can cause hearing loss.
2. **Use auxiliary handle(s), if supplied with the tool.** Loss of control can cause personal injury.
3. **Hold the power tool by insulated gripping surfaces, when performing an operation where the cutting accessory may contact hidden wiring.** Cutting accessory contacting a "live" wire may make exposed metal parts of the power tool "live" and could give the operator an electric shock.

Additional safety warnings

1. **Wear a hard hat (safety helmet), safety glasses and/or face shield.** Ordinary eye or sun glasses are NOT safety glasses. It is also highly recommended that you wear a dust mask and thickly padded gloves.
2. **Be sure the bit is secured in place before operation.**
3. **Under normal operation, the tool is designed to produce vibration. The screws can come loose easily, causing a breakdown or accident. Check tightness of screws carefully before operation.**
4. **In cold weather or when the tool has not been used for a long time, let the tool warm up for a while by operating it under no load. This will loosen up the lubrication. Without proper warm-up, hammering operation is difficult.**
5. **Always be sure you have a firm footing. Be sure no one is below when using the tool in high locations.**
6. **Hold the tool firmly with both hands.**
7. **Keep hands away from moving parts.**
8. **Do not leave the tool running. Operate the tool only when hand-held.**
9. **Do not point the tool at any one in the area when operating. The bit could fly out and injure someone seriously.**
10. **Do not touch the bit, parts close to the bit, or workpiece immediately after operation; they may be extremely hot and could burn your skin.**
11. **Some material contains chemicals which may be toxic. Take caution to prevent dust inhalation and skin contact. Follow material supplier safety data.**
12. **Always be sure that the tool is switched off and the battery cartridge and the bit are removed before handing the tool to other person.**
13. **Before operation, make sure that there is no buried object such as electric pipe, water pipe or gas pipe in the working area. Otherwise, the bit may touch them, resulting an electric shock, electrical leakage or gas leak.**
14. **Do not operate the tool at no-load unnecessarily.**

SAVE THESE INSTRUCTIONS.

⚠WARNING: DO NOT let comfort or familiarity with product (gained from repeated use) replace strict adherence to safety rules for the subject product. MISUSE or failure to follow the safety rules stated in this instruction manual may cause serious personal injury.

Important safety instructions for battery cartridge

1. Before using battery cartridge, read all instructions and cautionary markings on (1) battery charger, (2) battery, and (3) product using battery.
2. Do not disassemble or tamper with the battery cartridge. It may result in a fire, excessive heat, or explosion.
3. If operating time has become excessively shorter, stop operating immediately. It may result in a risk of overheating, possible burns and even an explosion.
4. If electrolyte gets into your eyes, rinse them out with clear water and seek medical attention right away. It may result in loss of your eyesight.
5. Do not short the battery cartridge:
 - (1) Do not touch the terminals with any conductive material.
 - (2) Avoid storing battery cartridge in a container with other metal objects such as nails, coins, etc.
 - (3) Do not expose battery cartridge to water or rain.

A battery short can cause a large current flow, overheating, possible burns and even a breakdown.

6. Do not store and use the tool and battery cartridge in locations where the temperature may reach or exceed 50 °C (122 °F).
7. Do not incinerate the battery cartridge even if it is severely damaged or is completely worn out. The battery cartridge can explode in a fire.
8. Do not nail, cut, crush, throw, drop the battery cartridge, or hit against a hard object to the battery cartridge. Such conduct may result in a fire, excessive heat, or explosion.
9. Do not use a damaged battery.
10. The contained lithium-ion batteries are subject to the Dangerous Goods Legislation requirements.

For commercial transports e.g. by third parties, forwarding agents, special requirement on packaging and labeling must be observed.

For preparation of the item being shipped, consulting an expert for hazardous material is required. Please also observe possibly more detailed national regulations.

Tape or mask off open contacts and pack up the battery in such a manner that it cannot move around in the packaging.

11. When disposing the battery cartridge, remove it from the tool and dispose of it in a safe place. Follow your local regulations relating to disposal of battery.
12. Use the batteries only with the products specified by Makita. Installing the batteries to non-compliant products may result in a fire, excessive heat, explosion, or leak of electrolyte.
13. If the tool is not used for a long period of time, the battery must be removed from the tool.

14. During and after use, the battery cartridge may take on heat which can cause burns or low temperature burns. Pay attention to the handling of hot battery cartridges.
15. Do not touch the terminal of the tool immediately after use as it may get hot enough to cause burns.
16. Do not allow chips, dust, or soil stuck into the terminals, holes, and grooves of the battery cartridge. It may cause heating, catching fire, burst and malfunction of the tool or battery cartridge, resulting in burns or personal injury.
17. Unless the tool supports the use near high-voltage electrical power lines, do not use the battery cartridge near high-voltage electrical power lines. It may result in a malfunction or breakdown of the tool or battery cartridge.
18. Keep the battery away from children.

SAVE THESE INSTRUCTIONS.

⚠CAUTION: Only use genuine Makita batteries. Use of non-genuine Makita batteries, or batteries that have been altered, may result in the battery bursting causing fires, personal injury and damage. It will also void the Makita warranty for the Makita tool and charger.

Tips for maintaining maximum battery life

1. Charge the battery cartridge before completely discharged. Always stop tool operation and charge the battery cartridge when you notice less tool power.
2. Never recharge a fully charged battery cartridge. Overcharging shortens the battery service life.
3. Charge the battery cartridge with room temperature at 10 °C - 40 °C (50 °F - 104 °F). Let a hot battery cartridge cool down before charging it.
4. When not using the battery cartridge, remove it from the tool or the charger.
5. Charge the battery cartridge if you do not use it for a long period (more than six months).

Important safety instructions for wireless unit

1. Do not disassemble or tamper with the wireless unit.
2. Keep the wireless unit away from young children. If accidentally swallowed, seek medical attention immediately.
3. Use the wireless unit only with Makita tools.
4. Do not expose the wireless unit to rain or wet conditions.
5. Do not use the wireless unit in places where the temperature exceeds 50 °C (122 °F).
6. Do not operate the wireless unit in places where medical instruments, such as heart pace makers are nearby.

7. Do not operate the wireless unit in places where automated devices are nearby. If operated, automated devices may develop malfunction or error.
8. Do not operate the wireless unit in places under high temperature or places where static electricity or electrical noise could be generated.
9. The wireless unit can produce electromagnetic fields (EMF) but they are not harmful to the user.
10. The wireless unit is an accurate instrument. Be careful not to drop or strike the wireless unit.
11. Avoid touching the terminal of the wireless unit with bare hands or metallic materials.
12. Always remove the battery on the product when installing the wireless unit into it.
13. When opening the lid of the slot, avoid the place where dust and water may come into the slot. Always keep the inlet of the slot clean.
14. Always insert the wireless unit in the correct direction.
15. Do not press the wireless activation button on the wireless unit too hard and/or press the button with an object with a sharp edge.
16. Always close the lid of the slot when operating.
17. Do not remove the wireless unit from the slot while the power is being supplied to the tool. Doing so may cause a malfunction of the wireless unit.
18. Do not remove the sticker on the wireless unit.
19. Do not put any sticker on the wireless unit.
20. Do not leave the wireless unit in a place where static electricity or electrical noise could be generated.
21. Do not leave the wireless unit in a place subject to high heat, such as a car sitting in the sun.
22. Do not leave the wireless unit in a dusty or powdery place or in a place corrosive gas could be generated.
23. Sudden change of the temperature may bedew the wireless unit. Do not use the wireless unit until the dew is completely dried.
24. When cleaning the wireless unit, gently wipe with a dry soft cloth. Do not use benzine, thinner, conductive grease or the like.
25. When storing the wireless unit, keep it in the supplied case or a static-free container.
26. Do not insert any devices other than Makita wireless unit into the slot on the tool.
27. Do not use the tool with the lid of the slot damaged. Water, dust, and dirt come into the slot may cause malfunction.
28. Do not pull and/or twist the lid of the slot more than necessary. Restore the lid if it comes off from the tool.
29. Replace the lid of the slot if it is lost or damaged.

SAVE THESE INSTRUCTIONS.

FUNCTIONAL DESCRIPTION

CAUTION: Always be sure that the tool is switched off and the battery cartridge is removed before adjusting or checking function on the tool.

Installing or removing battery cartridge

CAUTION: Always switch off the tool before installing or removing of the battery cartridge.

CAUTION: Hold the tool and the battery cartridge firmly when installing or removing battery cartridge. Failure to hold the tool and the battery cartridge firmly may cause them to slip off your hands and result in damage to the tool and battery cartridge and a personal injury.

To install the battery cartridge, align the tongue on the battery cartridge with the groove in the housing and slip it into place. Insert it all the way until it locks in place with a little click. If you can see the red indicator as shown in the figure, it is not locked completely.

To remove the battery cartridge, slide it from the tool while sliding the button on the front of the cartridge.

► Fig.1: 1. Red indicator 2. Button 3. Battery cartridge

CAUTION: Always install the battery cartridge fully until the red indicator cannot be seen. If not, it may accidentally fall out of the tool, causing injury to you or someone around you.

CAUTION: Do not install the battery cartridge forcibly. If the cartridge does not slide in easily, it is not being inserted correctly.

Indicating the remaining battery capacity

Press the check button on the battery cartridge to indicate the remaining battery capacity. The indicator lamps light up for a few seconds.

► Fig.2: 1. Indicator lamps 2. Check button

Indicator lamps			Remaining capacity
Lighted	Off	Blinking	
			75% to 100%
			50% to 75%
			25% to 50%
			0% to 25%
			Charge the battery.
			The battery may have malfunctioned.

NOTE: Depending on the conditions of use and the ambient temperature, the indication may differ slightly from the actual capacity.

NOTE: The first (far left) indicator lamp will blink when the battery protection system works.

Tool / battery protection system

The tool is equipped with a tool/battery protection system. This system automatically cuts off power to the motor to extend tool and battery life. The tool will automatically stop during operation if the tool or battery is placed under one of the following conditions:

Overload protection

When the tool or battery is operated in a manner that causes it to draw an abnormally high current, the tool automatically stops without any indication. In this situation, turn the tool off and stop the application that caused the tool to become overloaded. Then turn the tool on to restart.

Overheat protection

When the tool or battery is overheated, the tool stops automatically. In this case, let the tool and battery cool before turning the tool on again.

NOTE: When the tool is overheated, the bottom lamp blinks.

Overdischarge protection

When the battery capacity is not enough, the tool stops automatically. In this case, remove the battery from the tool and charge the battery.

Protections against other causes

Protection system is also designed for other causes that could damage the tool and allows the tool to stop automatically. Take all the following steps to clear the causes, when the tool has been brought to a temporary halt or stop in operation.

1. Turn the tool off, and then turn it on again to restart.
2. Charge the battery(ies) or replace it/them with recharged battery(ies).
3. Let the tool and battery(ies) cool down.

If no improvement can be found by restoring protection system, then contact your local Makita Service Center.

Switch action

⚠ WARNING: Before installing the battery cartridge into the tool, always check to see that the switch lever actuates properly and returns to the "OFF" position when released.

To start the tool, press the power switch to light up the power indicator lamp in green and then squeeze the switch lever. Release the switch lever to stop. To turn off the power of the tool, press the power switch to turn off the indicator lamp. Also, the power of the tool goes out approximately 5 minutes after releasing the switch lever.

- **Fig.3:** 1. Power switch 2. Power indicator lamp
3. Switch lever

Lighting up the bottom lamp

⚠ CAUTION: Do not look in the light or see the source of light directly.

Switch on the tool by pressing the power switch and squeeze the switch lever to light up the bottom lamp. The bottom lamp keeps on lighting while the switch lever is being squeezed. The bottom lamp goes out when the power switch is turned off or approximately 10 seconds after releasing the switch lever.

- **Fig.4:** 1. Bottom lamp

NOTE: When the tool is overheated, the bottom lamp blinks for one minute. In this case, cool down the tool before operating again.

NOTE: Use a dry cloth to wipe the dirt off the lens of the bottom lamp. Be careful not to scratch the lens of the bottom lamp, or it may lower the illumination.

Low battery warning

When the remaining battery capacity of even one of the two batteries becomes low, the power indicator lamp blinks in red. Charge the batteries or replace the charged batteries. When the remaining battery capacity becomes much lower, the power indicator lamp lights up in red and the tool stops.

- **Fig.5:** 1. Power indicator lamp

Maintenance warning

When the cumulative operating time of the tool exceeds 45 hours, the maintenance indicator lamp blinks in red. After 50 hours have elapsed, the maintenance indicator lamp lights up in red and the tool changes to the maintenance mode.

- **Fig.6:** 1. Maintenance indicator lamp

NOTE: The maintenance mode is selectable. The tool is initially set to the continuous operation mode.

NOTE: The tool does not work during configuration of the maintenance mode or during reset of the cumulative operating time.

Setting the maintenance mode

The maintenance mode is selectable.

1. Switch on the tool by pressing the power switch for 5 seconds while squeezing the switch lever. The maintenance indicator lamp blinks in red and the power indicator lamp indicates the current maintenance mode.
2. Press the power switch to select the desired maintenance mode.

Power indicator lamp	Maintenance mode
Green	Continuous operation mode
Red	Automatic stop mode

- **Fig.7:** 1. Power indicator lamp 2. Maintenance indicator lamp

3. Complete the setting by removing the battery from the tool or leaving the tool for approximately 5 minutes.

Recovering from the maintenance warning

To recover from the maintenance warning, reset the cumulative operating time.

1. Switch on the tool by pressing the power switch for 5 seconds while squeezing the switch lever.
2. Squeeze the switch lever for 5 seconds to reset the cumulative operating time of the tool. When the reset is completed, the power indicator lamp and maintenance indicator lamp light up in red and the bottom lamp also lights up.
3. After resetting the cumulative operating time, remove the battery from the tool or leave the tool for approximately 5 minutes.

Electronic function

The tool is equipped with the electronic functions for easy operation.

- Constant speed control
The speed control function provides the constant rotation speed regardless of load conditions.
- Soft start
The soft-start function minimizes start-up shock, and makes the machine start smoothly.

NOTE: Soft no-load rotation function

Blows at no load per minute becomes smaller than those on load in order to reduce vibration under no load, but this does not show trouble.

Once operation starts with a bit against concrete, blows per minute increase and reach the numbers as shown in the table.

ASSEMBLY

CAUTION: Always be sure that the tool is switched off and the battery cartridge is removed before carrying out any work on the tool.

Installing soft grip

The soft grip is not installed before factory shipment. Install soft grip securely. Match the shape of the soft grip mounting part to the shape of the main body mounting part and tighten the bolts firmly.

► Fig.8: 1. Soft grip 2. Bolt 3. Hex wrench



Installing or removing bit

Optional accessory

CAUTION: Always assure that the bit is securely retained by attempting to pull the bit out of the tool holder after installing the bit.

CAUTION: Follow the below 2 installation methods in accordance with the 2 different types of bits. If inappropriate installation method is selected, the bit cannot be secured.

This tool accepts bits either with or without a collar on its shank. To install the bit, follow either procedure (1) or (2) described below.

► Fig.9: 1. Bit with collar 2. Bit without collar

Bit grease

Optional accessory

Clean the shank end of the bit and apply grease before installing the bit.

Coat the shank end of the bit beforehand with a small amount of grease (about 0.5 - 1 g). This chuck lubrication assures smooth action and longer service life.

► Fig.10: 1. Shank end 2. Grease

(1) For bits with a collar

Pivot the tool retainer downward (approx. 60 degrees). Insert the bit into the tool holder until it stops. Return the tool retainer and secure the bit.

To remove the bit, follow the installation procedure in reverse.

► Fig.11: 1. Bit 2. Tool retainer 3. Tool holder

(2) For bits without a collar

Pivot the tool retainer upward (approx. 60 degrees). Face the notched portion of the bit upward. Insert the bit into the tool holder until it stops. Pivot the tool retainer further until it stops at the tool holder.

To remove the bit, follow the installation procedure in reverse.

► Fig.12: 1. Notched portion of the bit 2. Tool retainer 3. Tool holder

Installing or removing dust extractor attachment

Optional accessory

Installing dust extractor attachment

1. Install the hose holder as shown in this figure.

► Fig.13: 1. Hose holder 2. Hose

2. Install the dust cover as shown in this figure.

► Fig.14: 1. Dust cover 2. Hose 3. Bit with collar 4. 30 mm - 100 mm 5. Bit without collar

3. Connect the hose to the hose of the vacuum cleaner with the hose joint.

NOTE: If the hose is not included, attach the dust cover to the cleaner's joint or attach it to Makita's hose $\varnothing 28$.

Removing dust extractor attachment

Remove the dust extractor attachment in the reverse order of the installation.

OPERATION

CAUTION: Keep well-balanced posture when holding the heavy tool before / during / after operation to avoid personal injuries.

CAUTION: When you break the debris into smaller pieces, be careful of the flying debris.

CAUTION: Hold the tool firmly with both hands. Turn the tool on and apply slight pressure on the tool so that the tool will not bounce around, uncontrolled. Pressing very hard on the tool will not increase the efficiency.

CAUTION: Always make sure that the workpiece is secured before operation. Failure to properly secure the workpiece may cause the workpiece to move resulting in injury.

CAUTION: Do not pull out the tool if stuck. Instead, break the workpiece around the bit tip.

CAUTION: Do not leave the tool stabbed in the workpiece. Otherwise the tool may start unintentionally and cause an injury.

CAUTION: Be sure to place the tool on the stable floor or ground after use.

NOTE: If the battery cartridge is in low temperature, the tool's capability may not be fully obtained. In this case, warm up the battery cartridge by using the tool with no load for a while to fully obtain the tool's capability.

Chipping/Scaling/Demolition

Always use the soft grip (auxiliary handle) and firmly hold the tool by both the soft grip and the switch handle during operation.

► Fig.15

WIRELESS ACTIVATION FUNCTION

Optional accessory

What you can do with the wireless activation function

The wireless activation function enables clean and comfortable operation. By connecting a supported vacuum cleaner to the tool, you can run the vacuum cleaner automatically along with the switch operation of the tool.

► Fig.16

To use the wireless activation function, prepare following items:

- A wireless unit (optional accessory)
- A vacuum cleaner which supports the wireless activation function

The overview of the wireless activation function setting is as follows. Refer to each section for detail procedures.

1. Installing the wireless unit
2. Tool registration for the vacuum cleaner
3. Starting the wireless activation function

Installing the wireless unit

Optional accessory

CAUTION: Place the tool on a flat and stable surface when installing the wireless unit.

NOTICE: Clean the dust and dirt on the tool before installing the wireless unit. Dust or dirt may cause malfunction if it comes into the slot of the wireless unit.

NOTICE: To prevent the malfunction caused by static, touch a static discharging material, such as a metal part of the tool, before picking up the wireless unit.

NOTICE: When installing the wireless unit, always be sure that the wireless unit is inserted in the correct direction and the lid is completely closed.

1. Open the lid on the tool as shown in the figure.
► Fig.17: 1. Lid
2. Insert the wireless unit to the slot and then close the lid.

When inserting the wireless unit, align the projections with the recessed portions on the slot.

► Fig.18: 1. Wireless unit 2. Projection 3. Lid
4. Recessed portion

When removing the wireless unit, open the lid slowly. The hooks on the back of the lid will lift the wireless unit as you pull up the lid.

► Fig.19: 1. Wireless unit 2. Hook 3. Lid

After removing the wireless unit, keep it in the supplied case or a static-free container.

NOTICE: Always use the hooks on the back of the lid when removing the wireless unit. If the hooks do not catch the wireless unit, close the lid completely and open it slowly again.

Tool registration for the vacuum cleaner

NOTE: A Makita vacuum cleaner supporting the wireless activation function is required for the tool registration.

NOTE: Finish installing the wireless unit to the tool before starting the tool registration.

NOTE: During the tool registration, do not pull the switch trigger or turn on the power switch on the vacuum cleaner.

NOTE: Refer to the instruction manual of the vacuum cleaner, too.

If you wish to activate the vacuum cleaner along with the switch operation of the tool, finish the tool registration beforehand.

1. Install the batteries to the vacuum cleaner and the tool.
2. Set the stand-by switch on the vacuum cleaner to "AUTO".
► Fig.20: 1. Stand-by switch

3. Press the wireless activation button on the vacuum cleaner for 3 seconds until the wireless activation lamp blinks in green. And then press the wireless activation button on the tool in the same way.

► **Fig.21:** 1. Wireless activation button 2. Wireless activation lamp

If the vacuum cleaner and the tool are linked successfully, the wireless activation lamps will light up in green for 2 seconds and start blinking in blue.

NOTE: The wireless activation lamps finish blinking in green after 20 seconds elapsed. Press the wireless activation button on the tool while the wireless activation lamp on the cleaner is blinking. If the wireless activation lamp does not blink in green, push the wireless activation button briefly and hold it down again.

NOTE: When performing two or more tool registrations for one vacuum cleaner, finish the tool registration one by one.

Starting the wireless activation function

NOTE: Finish the tool registration for the vacuum cleaner prior to the wireless activation.

NOTE: Refer to the instruction manual of the vacuum cleaner, too.

After registering a tool to the vacuum cleaner, the vacuum cleaner will automatically run along with the switch operation of the tool.

1. Install the wireless unit to the tool.
2. Connect the hose of the vacuum cleaner with the tool.

► **Fig.22**

3. Set the stand-by switch on the vacuum cleaner to "AUTO".

► **Fig.23:** 1. Stand-by switch

4. Push the wireless activation button on the tool briefly. The wireless activation lamp will blink in blue.

► **Fig.24:** 1. Wireless activation button 2. Wireless activation lamp

5. Turn on the tool. Check if the vacuum cleaner runs while the tool is operating.

To stop the wireless activation of the vacuum cleaner, push the wireless activation button on the tool.

NOTE: The wireless activation lamp on the tool will stop blinking in blue when there is no operation for 2 hours. In this case, set the stand-by switch on the vacuum cleaner to "AUTO" and push the wireless activation button on the tool again.

NOTE: The vacuum cleaner starts/stops with a delay. There is a time lag when the vacuum cleaner detects a switch operation of the tool.

NOTE: The transmission distance of the wireless unit may vary depending on the location and surrounding circumstances.

NOTE: When two or more tools are registered to one vacuum cleaner, the vacuum cleaner may start running even if you do not turn on your tool because another user is using the wireless activation function.

Description of the wireless activation lamp status

► **Fig.25:** 1. Wireless activation lamp

The wireless activation lamp shows the status of the wireless activation function. Refer to the table below for the meaning of the lamp status.

Status	Wireless activation lamp			Duration	Description
	Color	<input type="checkbox"/> On	<input type="checkbox"/> Blinking		
Standby	Blue	<input checked="" type="checkbox"/>		2 hours	The wireless activation of the vacuum cleaner is available. The lamp will automatically turn off when no operation is performed for 2 hours.
		<input type="checkbox"/>		When the tool is running.	The wireless activation of the vacuum cleaner is available and the tool is running.
Tool registration	Green	<input checked="" type="checkbox"/>		20 seconds	Ready for the tool registration. Waiting for the registration by the vacuum cleaner.
		<input type="checkbox"/>		2 seconds	The tool registration has been finished. The wireless activation lamp will start blinking in blue.
Cancelling tool registration	Red	<input checked="" type="checkbox"/>		20 seconds	Ready for the cancellation of the tool registration. Waiting for the cancellation by the vacuum cleaner.
		<input type="checkbox"/>		2 seconds	The cancellation of the tool registration has been finished. The wireless activation lamp will start blinking in blue.
Others	Red	<input type="checkbox"/>		3 seconds	The power is supplied to the wireless unit and the wireless activation function is starting up.
	Off	-		-	The wireless activation of the vacuum cleaner is stopped.

Cancelling tool registration for the vacuum cleaner

Perform the following procedure when cancelling the tool registration for the vacuum cleaner.

1. Install the batteries to the vacuum cleaner and the tool.

2. Set the stand-by switch on the vacuum cleaner to "AUTO".

► **Fig.26:** 1. Stand-by switch

3. Press the wireless activation button on the vacuum cleaner for 6 seconds. The wireless activation lamp blinks in green and then become red. After that, press the wireless activation button on the tool in the same way.

► **Fig.27:** 1. Wireless activation button 2. Wireless activation lamp

If the cancellation is performed successfully, the wireless activation lamps will light up in red for 2 seconds and start blinking in blue.

NOTE: The wireless activation lamps finish blinking in red after 20 seconds elapsed. Press the wireless activation button on the tool while the wireless activation lamp on the cleaner is blinking. If the wireless activation lamp does not blink in red, push the wireless activation button briefly and hold it down again.



МАГАЗИН
БАШ МАЙСТОРА®
ПРОФЕСИОНАЛНИ РЕШЕНИЯ

Troubleshooting for wireless activation function

Before asking for repairs, conduct your own inspection first. If you find a problem that is not explained in the manual, do not attempt to dismantle the tool. Instead, ask Makita Authorized Service Centers, always using Makita replacement parts for repairs.

State of abnormality	Probable cause (malfunction)	Remedy
The wireless activation lamp does not light/blink.	The wireless unit is not installed into the tool. The wireless unit is improperly installed into the tool.	Install the wireless unit correctly.
	The terminal of the wireless unit and/or the slot is dirty.	Gently wipe off dust and dirt on the terminal of the wireless unit and clean the slot.
	The wireless activation button on the tool has not been pushed.	Push the wireless activation button on the tool briefly.
	The stand-by switch on the vacuum cleaner is not set to "AUTO".	Set the stand-by switch on the vacuum cleaner to "AUTO".
	No power supply	Supply the power to the tool and the vacuum cleaner.
Cannot finish tool registration / cancelling tool registration successfully.	The wireless unit is not installed into the tool. The wireless unit is improperly installed into the tool.	Install the wireless unit correctly.
	The terminal of the wireless unit and/or the slot is dirty.	Gently wipe off dust and dirt on the terminal of the wireless unit and clean the slot.
	The stand-by switch on the vacuum cleaner is not set to "AUTO".	Set the stand-by switch on the vacuum cleaner to "AUTO".
	No power supply	Supply the power to the tool and the vacuum cleaner.
	Incorrect operation	Push the wireless activation button briefly and perform the tool registration/cancellation procedures again.
	The tool and vacuum cleaner are away from each other (out of the transmission range).	Get the tool and vacuum cleaner closer to each other. The maximum transmission distance is approximately 10 m however it may vary according to the circumstances.
	Before finishing the tool registration/cancellation; - the switch of the tool is turned on or; - the power button on the vacuum cleaner is turned on.	Push the wireless activation button briefly and perform the tool registration/cancellation procedures again.
	The tool registration procedures for the tool or vacuum cleaner have not finished.	Perform the tool registration procedures for both the tool and the vacuum cleaner at the same timing.
The vacuum cleaner does not run along with the switch operation of the tool.	The wireless unit is not installed into the tool. The wireless unit is improperly installed into the tool.	Install the wireless unit correctly.
	The terminal of the wireless unit and/or the slot is dirty.	Gently wipe off dust and dirt on the terminal of the wireless unit and clean the slot.
	The wireless activation button on the tool has not been pushed.	Push the wireless activation button briefly and make sure that the wireless activation lamp is blinking in blue.
	The stand-by switch on the vacuum cleaner is not set to "AUTO".	Set the stand-by switch on the vacuum cleaner to "AUTO".
	More than 10 tools are registered to the vacuum cleaner.	Perform the tool registration again. If more than 10 tools are registered to the vacuum cleaner, the tool registered earliest will be cancelled automatically.
	The vacuum cleaner erased all tool registrations.	Perform the tool registration again.
	No power supply	Supply the power to the tool and the vacuum cleaner.
	The tool and vacuum cleaner are away from each other (out of the transmission range).	Get the tool and vacuum cleaner closer each other. The maximum transmission distance is approximately 10 m however it may vary according to the circumstances.
Radio disturbance by other appliances which generate high-intensity radio waves.	Keep the tool and vacuum cleaner away from the appliances such as Wi-Fi devices and microwave ovens.	
The vacuum cleaner runs while the tool is not operating.	Other users are using the wireless activation of the vacuum cleaner with their tools.	Turn off the wireless activation button of the other tools or cancel the tool registration of the other tools.

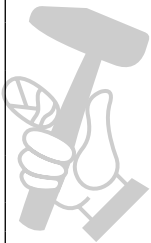

MAINTENANCE

⚠ CAUTION: Always be sure that the tool is switched off and the battery cartridge is removed before attempting to perform inspection or maintenance.

⚠ CAUTION: Store the machine in horizontal position to avoid possible grease leakage.

NOTICE: Never use gasoline, benzine, thinner, alcohol or the like. Discoloration, deformation or cracks may result.

To maintain product SAFETY and RELIABILITY, repairs, any other maintenance or adjustment should be performed by Makita Authorized or Factory Service Centers, always using Makita replacement parts.

OPTIONAL ACCESSORIES

⚠ CAUTION: These accessories or attachments are recommended for use with your Makita tool specified in this manual. The use of any other accessories or attachments might present a risk of injury to persons. Only use accessory or attachment for its stated purpose.

If you need any assistance for more details regarding these accessories, ask your local Makita Service Center.

- Bull point
- Cold chisel
- Scaling chisel
- Clay spade
- Rammer
- Bit grease
- Dust extractor attachment
- Wireless unit
- Makita genuine battery and charger

NOTE: Some items in the list may be included in the tool package as standard accessories. They may differ from country to country.

