

RAIDER

PPO



RAIDER[®] **Pro**

- Абрихт & Щрайхмус
- Planner Thicknesser
- Rindeau de grosime

Contents

3	BG	схема
7	EN	original instructions' manual
21	BG	оригинална инструкция за употреба
34	RO	Instrucțiuni originale

RDP-APT02

USER'S MANUAL



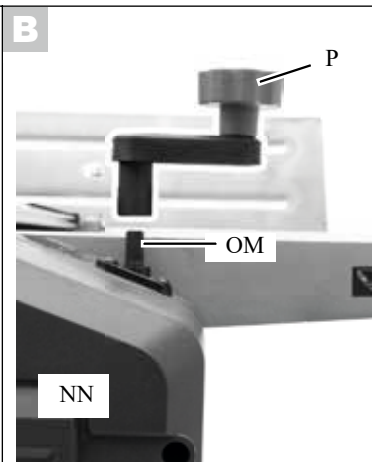
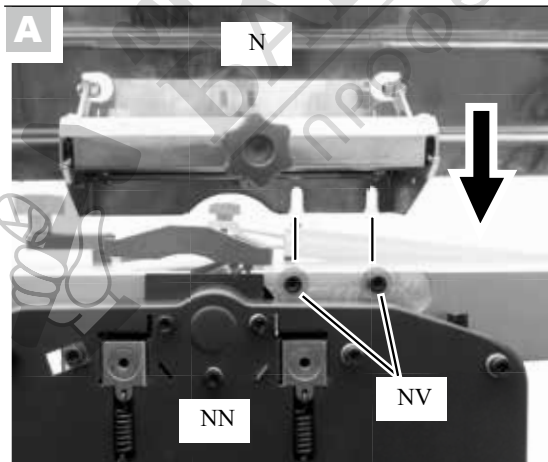
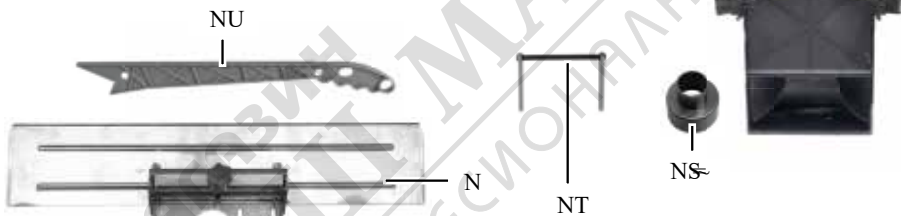
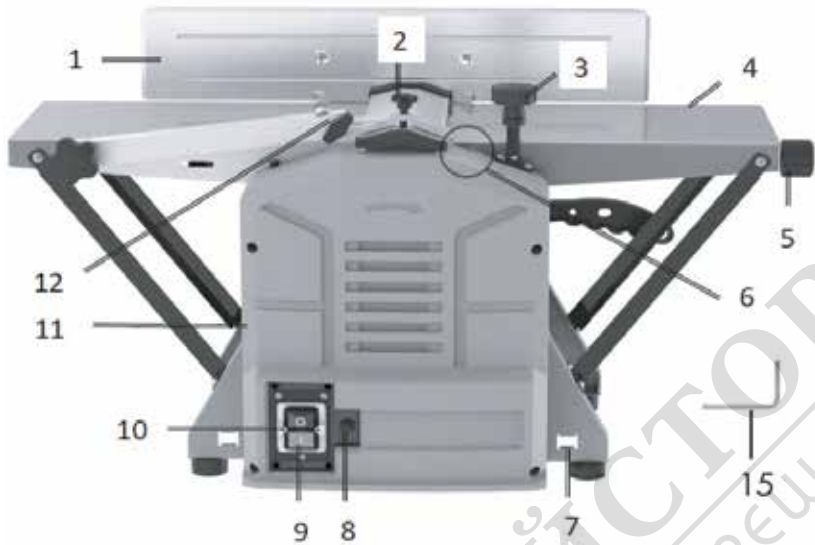

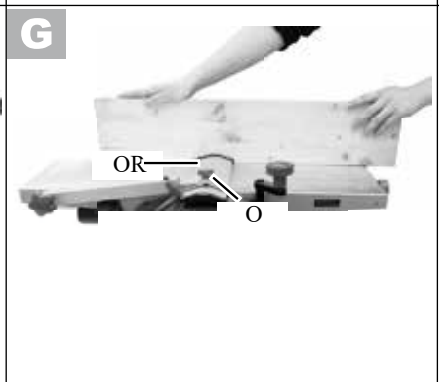
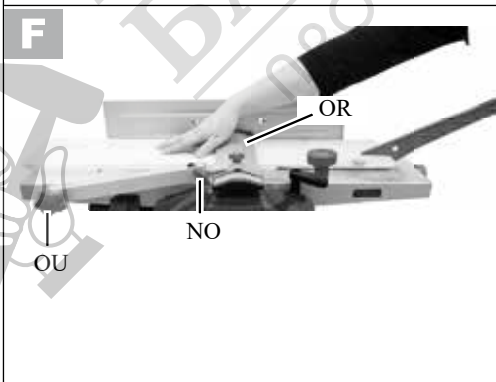
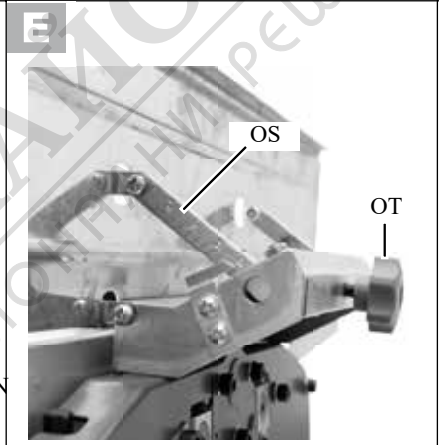
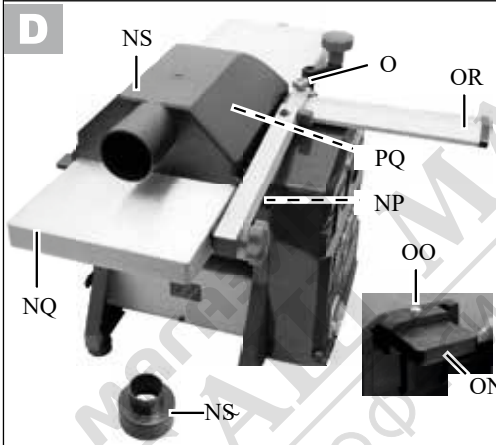
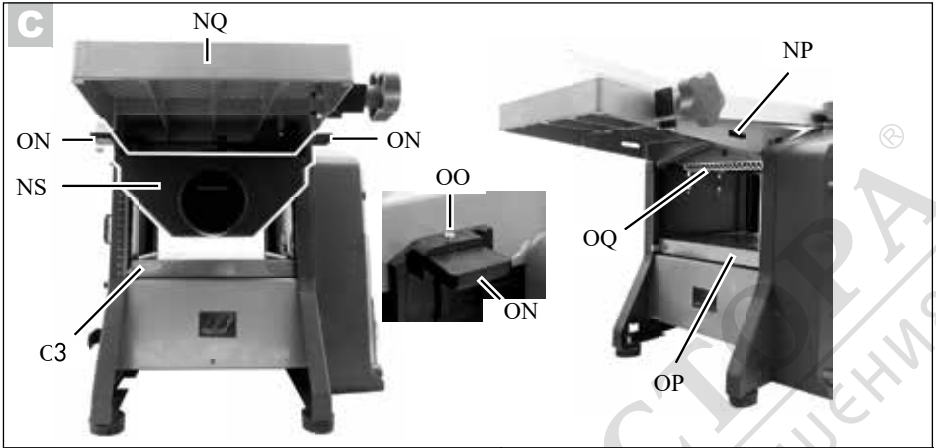

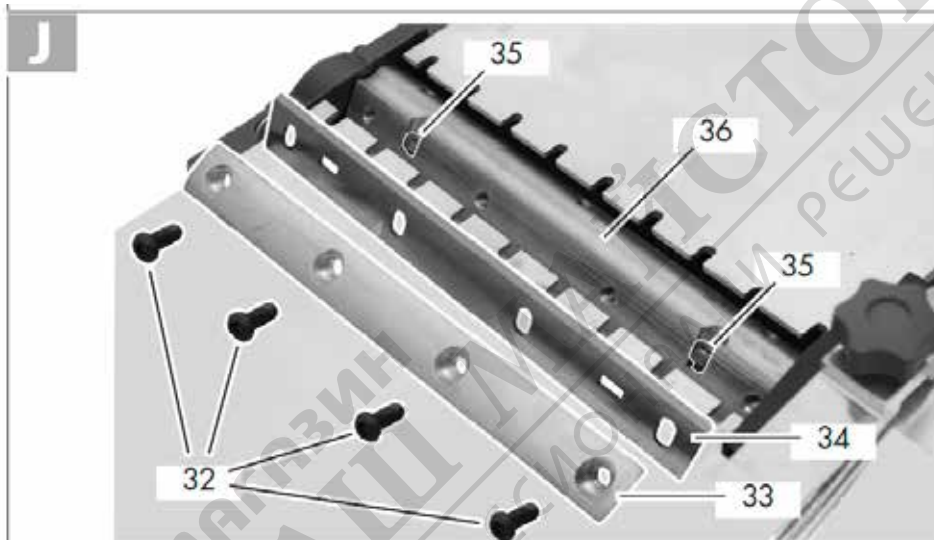
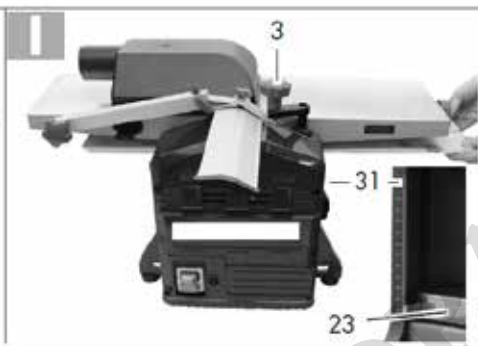
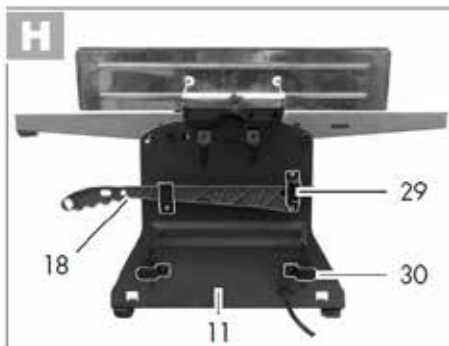



МАГАЗИН
БАШ МАЙСТОРА®
ПРОФЕСИОНАЛНИ РЕШЕНИЯ

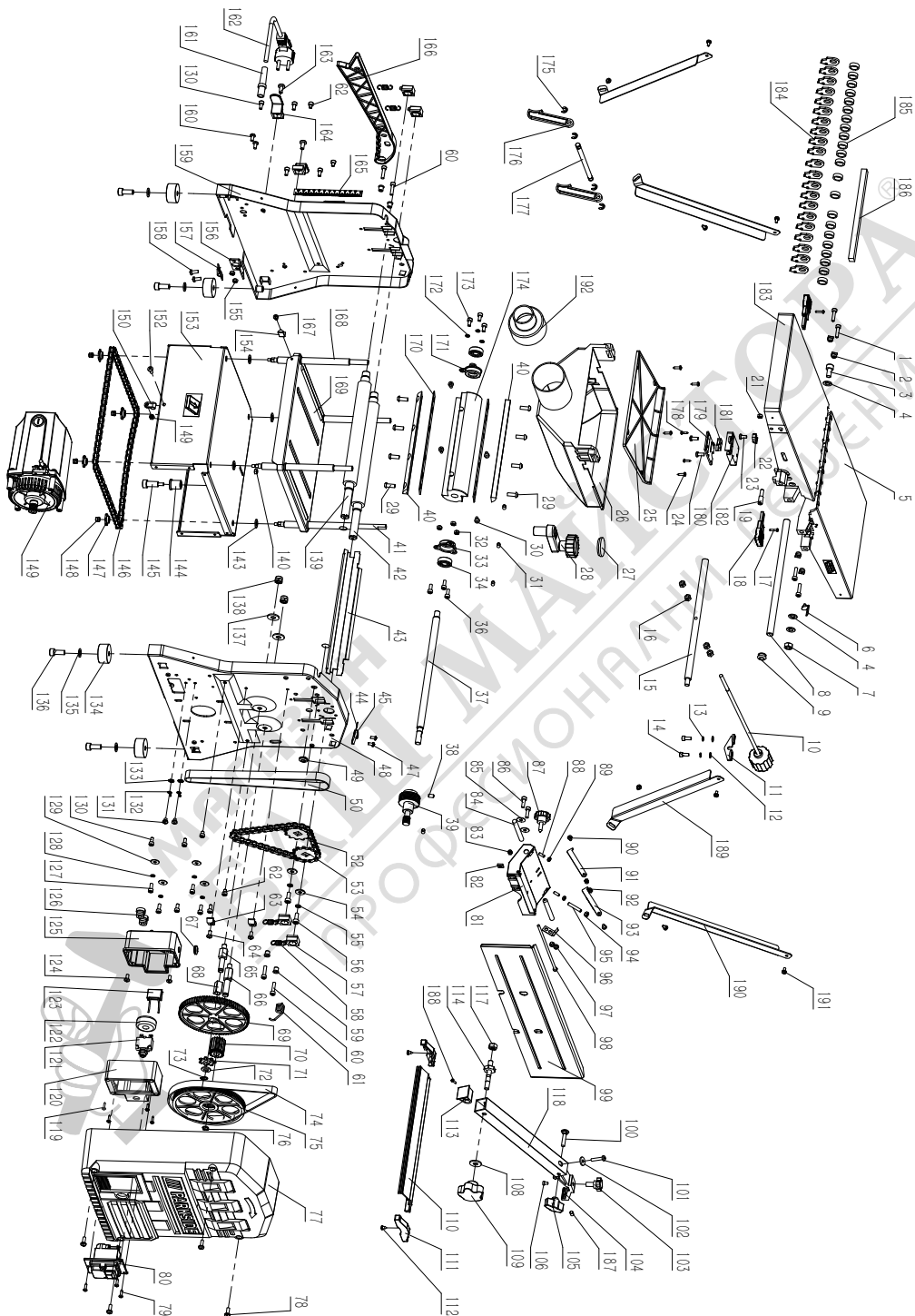

EXPLODED VIEW AND SPARE PARTS LIST

No.	Name	Material Mark	Qty.
1	Inner hexagon screws	M5*20	4
2	Pressure sleeve		4
3	Inner hexagon screws	M8*12	1
4	Flat pad	φ8*φ16*1.5	3
5	Activity worktable		1
6	Depth pointer		1
7	Nut	M8	1
8	Hanging rod		1
9	Out of the coil		1
10	Adjusting rod assembly		1
11	Adjust the rod seat		1
12	Flat pad	φ5	2
13	Spring cushion	φ5	2
14	Inner hexagon screws	M5*12	2
15	Tie rod		1
16	Nut	M6	4
17	Self-tapping screws	ST2.9*14	2
18	Switch pressure plate		2
19	Stop pin		1
21	Nut	M6	1
22	Crimping button		1
23	Cross screw	M5*10	1
24	Self-tapping screws	ST3.5*12	4
25	Chip cover cover		1
26	Ash out cover		1
27	Crank handle cover		1
28	Crank components		1
29	Inner hexagon flat head screws	M6*16	8
30	Blade card screw	M4*10	4
31	Flat screw	M6*10	3
32	Nut	M5	3
33	Bearing seat 1		1
34	Bearing	6000	2
36	Inner hexagon screws	M5*12	3
37	Tool axis		1
38	Flat screw	M6*10	2
39	Knife shaft pulley		1
40	Blade press block		2
41	Active screw		1
42	Rubber roller assembly		1
43	Baffle		1
44	Planing depth label		1
45	Screw spacer		1
47	Cross screw	M4*8	2
48	Master board		1
49	Outlet guard ring		1
50	Secondary belt		1
52	Drive chain		1
53	Big sprocket		2
54	Flat pad	φ6*φ18	2
55	Spring pad	φ6	2
56	Inner hexagon screws	M6*14	2
57	Briquetting		4
58	Compression spring		4
59	Workbench positioning sleeve		4
60	Inner hexagon screws	M5*20	4
61	Torsion spring		1

62	Inner hexagon screws	M5*6	4
63	Crimping button		2
64	Cross screw	M5*8	2
65	Gear shaft		1
66	Wheel shaft		1
67	Outlet guard ring		1
68	Square set		1
69	big gear	PA6	1
70	gear		1
71	Small sprocket		1
72	Flat pad	φ9*φ17*2	1
73	Circlip for shaft	φ9	1
74	Primary belt		1
75	Big pulley		1
76	Circlip for shaft	φ10	1
77	Cover		1
78	Cross two combination	M5*14	4
79	Self-tapping screws	ST3.5*14	3
80	switch		1
81	Backing support		1
82	Square thin nuts	M6	1
83	Self-locking nuts	M4	1
84	Backer locking lever		2
85	Flat pad	φ5*φ16	2
86	Inner hexagon screws	M5*16	2
87	Backer handle		1
88	Flat set screw	M4*12	2
89	Nut	M4	2
90	Cross screw	M4*10	2
91	Backer connecting plate		1
92	Self-locking nuts	M4	2
93	Backer scale plate		1
94	Nut	M5	1
95	Flat set screw	M5*30	1
96	Backer pointer		1
97	Cross two combination	M4*6	2
98	Cross screw	M4*170	1
99	backing		1
100	Carriage screw	M6*35	1
101	Phillips pan head screws	M5*25	1
102	Gasket	φ5*φ16	1
103	Plum blossom handle	M8*11	1
104	Guard bracket		1
105	Triangle knob	M6	1
106	Locking pad		1
108	Flat pad	φ8*φ22*2	1
109	Cantilever lock handle	M8	1
110	Aluminum alloy shield		1
111	Shield cover		2
112	Phillips tapping screws	ST4.2*8	2
113	Cantilever cover		1
114	Positioning screw		1
116	Positioning screw pin		1
117	Nut	M8	1
118	cantilever		1
119	Two combination self-tapping screws	ST4.2*14	4

120	Switch box cover		1
121	Overload protector		1
122	inductance		1
123	capacitance		1
124	Cross screw	M5*10	2
125	Switch box bottom		1
126	Wide slot for crimping card		2
127	Socket head cap screws	M5*12	4
128	Spring cushion	φ5	4
129	Flat pad	φ5*φ16	4
130	Socket head cap screws	M5*10	8
131	Cross two combination screw	M5*10	2
132	Ground lug	φ5	2
133	Tooth pad	φ5	2
134	Feet		4
135	Flat pad	φ8	4
136	Inner hexagon screws	M8*20	4
137	Flat pad	φ8*φ22*2	2
138	Self-locking nuts	M8	2
139	Rubber roller assembly		1
140	Nut	M5	1
143	Flat pad	φ8	4
144	Tensioning sleeve (chain)		1
145	Tension set screw		1
146	Regulating chain		1
147	Adjust the sprocket		4
148	Self-locking nuts	M5	4
149	Motor assembly		1
150	Plastic crimping board		1
151	Nut	M5	1
152	Cross screw	M5*12	1
153	Positioning table		1
154	Platform pointer		1
155	Nut	M5	2
156	Big right angle		1

157	Bridge		1
158	Cross screw	M5*12	2
159	Vice station board		1
160	Cross screw	M5*12	2
161	Lengthened outlet hose B		1
162	Power cord + plug		1
163	Cross screw	M6*12	2
164	Winding card		2
165	Lifting scale label		1
166	Putter		1
167	Cross three combinations	M4*8*8	1
168	Driven screw		3
169	Work platform		1
170	blade		2
171	Bearing seat 2		1
172	Spring cushion	φ5	3
173	Inner hexagon screws	M5*10	3
174	Knife holder		1
175	Open retaining ring	φ6	4
176	Knife block		2
177	Set axis		1
178	Self-tapping screws	ST2.9*12	2
179	Micro-motion box cover		1
180	Cross screw	M5*12	2
181	Small micro switch		1
182	Micro-motion box bottom		1
183	Fixed workbench		1
184	Ratchet stop		21
185	Stop spacer		22
186	Sponge mats		1
187	Plastic set screw		1
188	Self tapping screw	ST2.9*10	1
189	Support frame 2		2
190	Support frame 1		2
191	Metal tapping screw	M4*8	8
192	Pipe joint of chip discharge cover		1

